

CUSTOMER APPROVAL

NAME: _____

DATE: _____

IMPORTANT: BY SIGNING THIS DRAWING YOU ARE APPROVING IT AS IS. IF CHANGES ARE REQUIRED, A NEW DRAWING WILL BE REQUIRED.

Gillette Generator	SPVD-3000
Customer P/N #	S-524
Isolator model	None

Fittings	Description
1	5" NPT, Emergency tank vent
3	2" NPT, Normal tank vent
4	2" NPT, Tank fill with 6" riser and lockable fill cap
5	2" NPT, Direct reading gauge
6	1" NPT, Engine supply, 1/2" NPT full length dip tube
7	1" NPT, Engine return, 1/2" NPT full length dip tube
8A	2" NPT, Fuel level switch
8B	2" NPT, Fuel level switch
9	2" NPT, Visual inspection into basin
10	1/2" NPT, Rupture basin switch
14	1/2" NPT, Basin drain, plugged
15	(2) 2" NPT, Spare fitting, plugged

Double wall secondary containment General Notes:

Fillable - 533 Gallons

Usable - 524 Gallons

Weight - 2,250 Lbs.

Andrew Miller

Digitally signed by Andrew Miller
 DN: cn=Andrew Miller, o=Gillette Generators, Inc., ou=Engineering, email=engineering@gillettegenerators.com, c=US
 Date: 2018.01.04 14:18:01 -05'00'

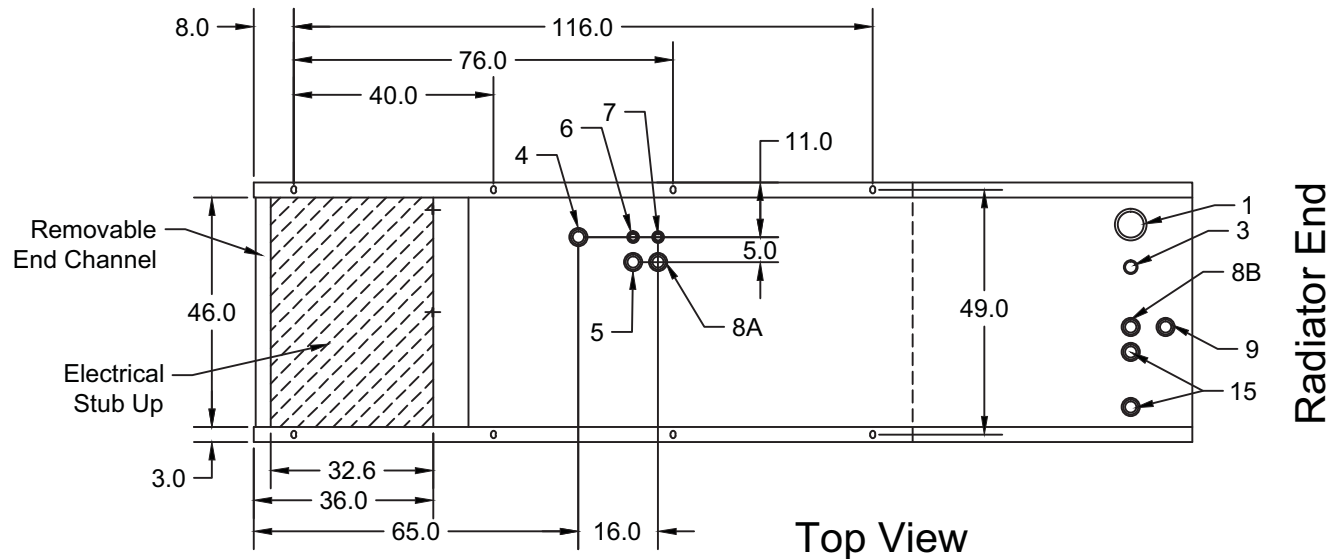

Top View

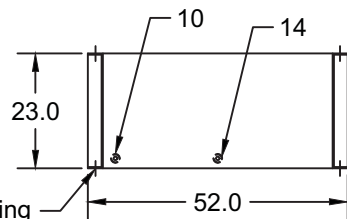

See Pad Layout drawing for size and location of sub base mounting slots

Generator End

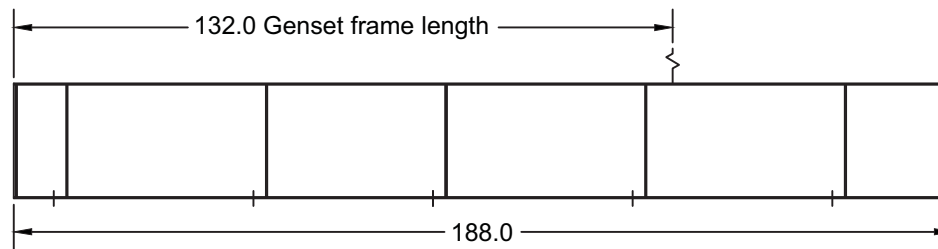

Side View



THIS DESIGN IS THE CONFIDENTIAL PROPERTY OF TRAMONT MFG. FOR USE BY TRAMONT MFG. CUSTOMERS FOR SUBMITTAL PURPOSES ONLY. IN LINE WITH CONTINUOUS PRODUCT DEVELOPMENT, WE RESERVE THE RIGHT TO CHANGE THE SPECIFICATIONS WITHOUT NOTICE



DRAWN BY:	XX	DATE:	01/03/18
CHK'D:		DATE:	
APPROVED:		DATE:	
SCALE:	NTS		

DESCRIPTION:		524 Gallon, Closed Top Diked Gen. Sub Base Tank	
FOR:	Submittal, Tank	SHEET	DRAWING NO.:
		1 of 2	S8G00147

S. Rev	Date	Description	Name
00	01/03/18	Start (S8G00116)	XX
Change Block			

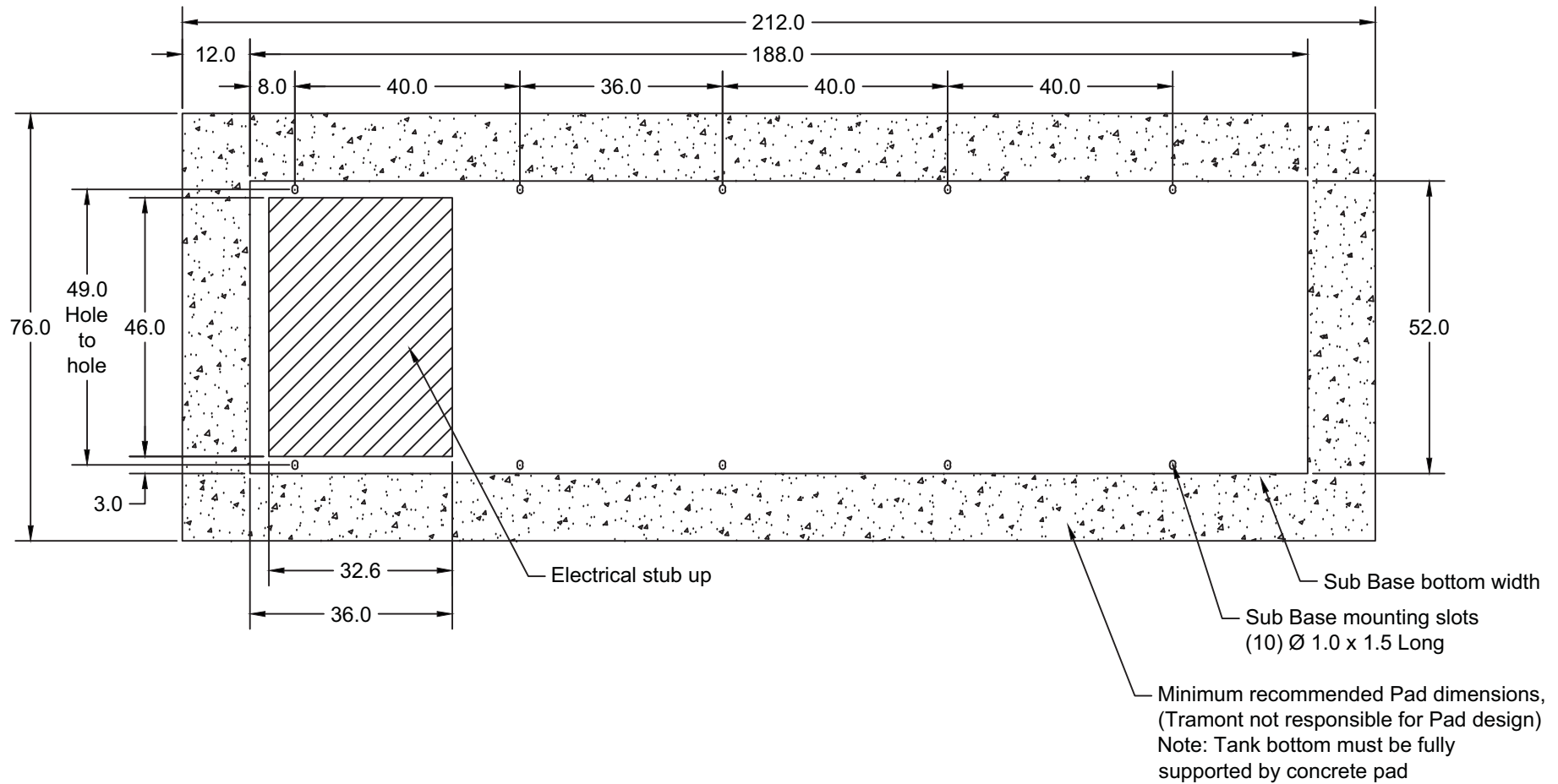

THIS DESIGN IS THE CONFIDENTIAL PROPERTY OF TRAMONT MFG. FOR USE BY TRAMONT MFG. CUSTOMERS FOR SUBMITTAL PURPOSES ONLY. IN LINE WITH CONTINUOUS PRODUCT DEVELOPMENT, WE RESERVE THE RIGHT TO CHANGE THE SPECIFICATIONS WITHOUT NOTICE			
DRAWN BY: XX		DATE: 01/03/18	
CHK'D:		DATE:	
APPROVED:		DATE:	
SCALE: NTS		DESCRIPTION: 524 Gallon, Closed Top Diked Gen. Sub Base Tank	
FOR: Submittal, Pad Layout		SHEET: 2of2	DRAWING NO.: S8G00147



S. Rev	Date	Description	Name
00	01/03/18	Start	XX
Change Block			