



OPERATION AND PARTS MANUAL



WHISPERWATT™ SERIES MODEL DCA125SSIU 60HZ GENERATOR (ISUZU 4HK1X DIESEL ENGINE)

PARTS LIST NO. M3870301204

Revision #3 (01/14/11)

To find the latest revision of this
publication, visit our website at:
www.mqpower.com



THIS MANUAL MUST ACCOMPANY THE EQUIPMENT AT ALL TIMES.



CALIFORNIA — Proposition 65 Warning

Diesel engine exhaust and some of its constituents are known to the State of California to cause cancer, birth defects and other reproductive harm.

REPORTING SAFETY DEFECTS

If you believe that your vehicle has a defect that could cause a crash or could cause injury or death, you should immediately inform the National Highway Traffic Safety Administration (NHTSA) in addition to notifying Multiquip at 1-800-421-1244.

If NHTSA receives similar complaints, it may open an investigation, and if it finds that a safety defect exists in a group of vehicles, it may order a recall and remedy campaign. However, NHTSA cannot become involved in individual problems between you, your dealer, or Multiquip.

To contact NHTSA, you may either call the Vehicle Safety Hotline toll-free at 1-888-327-4236 (TTY: 1-800-424-9153), go to <http://www.nhtsa.dot.gov>; or write to:

Administrator
NHTSA
1200 New Jersey Avenue S.E.
Washington, DC 20590

You can also obtain information about motor vehicle safety from <http://www.safecar.gov>.

TABLE OF CONTENTS

DCA125SSIU Generator

Proposition 65 Warning	2
Reporting Safety Defects.....	3
Table Of Contents.....	4
Parts Ordering Procedures.....	5
Safety Information	6-11
Specifications	12
Dimensions.....	13
Installation	14-15
General Information.....	16
Major Components	17
Generator Control Panel.....	18
Engine Operating Panel.....	20-21
Output Terminal Panel Familiarization	22-24
Load Application	25
Generator Outputs.....	26-27
Gauge Reading	27
Output Terminal Panel Connections	28-29
Inspection/Setup.....	30-33
Generator Start-Up Procedure (Manual)	34-35
Generator Start-Up Procedure (Auto Mode)	36
Generator Shut-Down Procedures	37
Maintenance	38-41
Trailer Maintenance	42-45
Trailer Wiring Diagram	46
Generator Wiring Diagram.....	47
Engine Wiring Diagram.....	48
Controller Wiring Diagram	49
Troubleshooting (Generator).....	50
Troubleshooting (Engine Controller)	51
Troubleshooting (Diagnostic Lamp)	52
Explanation Of Code In Remarks Column.....	54
Suggested Spare Parts	55

Component Drawings

Generator Assembly.....	56-57
Control Box Assembly	58-63
Engine And Radiator Assembly	64-67
Output Terminal AsseMbly.....	68-69
Battery Assembly.....	70-71
Muffler Assembly	72-73
Fuel Tank Assembly	74-75
Enclosure Assembly	76-81
Rubber Seals Assembly	82-83
Nameplate And Decals Assembly	84-87
Terms And Conditions Of Sale — Parts	88

PARTS ORDERING PROCEDURES

www.mqpower.com

Ordering parts has never been easier! Choose from three easy options:

Effective:
January 1st, 2006



Order via Internet (Dealers Only):

Order parts on-line using Multiquip's SmartEquip website!

- View Parts Diagrams
- Order Parts
- Print Specification Information



If you have an MQ Account, to obtain a Username and Password, E-mail us at: parts@multiquip.com.

To obtain an MQ Account, contact your District Sales Manager for more information.

Goto www.multiquip.com and click on **Order Parts** to log in and save!

Use the **internet** and qualify for a **5% Discount** on *Standard orders* for all orders which include complete part numbers.*

Note: Discounts Are Subject To Change



Order via Fax (Dealers Only):

All customers are welcome to order parts via Fax.

Domestic (US) Customers dial:
1-800-6-PARTS-7 (800-672-7877)

Fax your order in and qualify for a **2% Discount** on *Standard orders* for all orders which include complete part numbers.*

Note: Discounts Are Subject To Change



Order via Phone: Domestic (US) Dealers Call:
1-800-427-1244

Non-Dealer Customers:

Contact your local Multiquip Dealer for parts or call 800-427-1244 for help in locating a dealer near you.



International Customers should contact their local Multiquip Representatives for Parts Ordering information.

When ordering parts, please supply:

- | | |
|---|--|
| <input type="checkbox"/> Dealer Account Number | <input type="checkbox"/> Specify Preferred Method of Shipment: |
| <input type="checkbox"/> Dealer Name and Address | <input checked="" type="checkbox"/> UPS/Fed Ex <input checked="" type="checkbox"/> DHL |
| <input type="checkbox"/> Shipping Address (if different than billing address) | <input type="checkbox"/> Priority One <input checked="" type="checkbox"/> Truck |
| <input type="checkbox"/> Return Fax Number | <input type="checkbox"/> Ground |
| <input type="checkbox"/> Applicable Model Number | <input type="checkbox"/> Next Day |
| <input type="checkbox"/> Quantity, Part Number and Description of Each Part | <input type="checkbox"/> Second/Third Day |

NOTICE

All orders are treated as *Standard Orders* and will ship the same day if received prior to 3PM PST.

WE ACCEPT ALL MAJOR CREDIT CARDS!



SAFETY INFORMATION

Do not operate or service the equipment before reading the entire manual. Safety precautions should be followed at all times when operating this equipment. Failure to read and understand the safety messages and operating instructions could result in injury to yourself and others.

SAFETY MESSAGES

The four safety messages shown below will inform you about potential hazards that could injure you or others. The safety messages specifically address the level of exposure to the operator and are preceded by one of four words: **DANGER**, **WARNING**, **CAUTION** or **NOTICE**.

SAFETY SYMBOLS

! DANGER

Indicates a hazardous situation which, if not avoided, **WILL** result in **DEATH** or **SERIOUS INJURY**.

! WARNING

Indicates a hazardous situation which, if not avoided, **COULD** result in **DEATH** or **SERIOUS INJURY**.







! CAUTION

Indicates a hazardous situation which, if not avoided, **COULD** result in **MINOR** or **MODERATE INJURY**.

NOTICE

Addresses practices not related to personal injury.

Potential hazards associated with the operation of this equipment will be referenced with hazard symbols which may appear throughout this manual in conjunction with safety messages.

Symbol	Safety Hazard
	Lethal exhaust gas hazards
	Explosive fuel hazards
	Burn hazards
	Overspeed hazards
	Rotating parts hazards
	Pressurized fluid hazards
	Electric shock hazards

SAFETY INFORMATION

GENERAL SAFETY

CAUTION

- **NEVER** operate this equipment without proper protective clothing, shatterproof glasses, respiratory protection, hearing protection, steel-toed boots and other protective devices required by the job or city and state regulations.



- **NEVER** operate this equipment when not feeling well due to fatigue, illness or when under medication.
- **NEVER** operate this equipment under the influence of drugs or alcohol.



- **ALWAYS** check the equipment for loosened threads or bolts before starting.
- **DO NOT** use the equipment for any purpose other than its intended purposes or applications.

NOTICE

- This equipment should only be operated by trained and qualified personnel 18 years of age and older.
- Whenever necessary, replace nameplate, operation and safety decals when they become difficult read.
- Manufacturer does not assume responsibility for any accident due to equipment modifications. Unauthorized equipment modification will void all warranties.

- **NEVER** use accessories or attachments that are not recommended by MQ Power for this equipment. Damage to the equipment and/or injury to user may result.

- **ALWAYS** know the location of the nearest **fire extinguisher**.



- **ALWAYS** know the location of the nearest **first aid kit**.



- **ALWAYS** know the location of the nearest phone or **keep a phone on the job site**. Also, know the phone numbers of the nearest **ambulance, doctor and fire department**. This information will be invaluable in the case of an emergency.



GENERATOR SAFETY

DANGER

- **NEVER** operate the equipment in an explosive atmosphere or near combustible materials. An explosion or fire could result causing severe **bodily harm or even death**.



WARNING

- **NEVER** disconnect any **emergency or safety devices**. These devices are intended for operator safety. Disconnection of these devices can cause severe injury, bodily harm or even death. Disconnection of any of these devices will void all warranties.

CAUTION

- **NEVER** lubricate components or attempt service on a running machine.

NOTICE

- **ALWAYS** ensure generator is on level ground before use.
- **ALWAYS** keep the machine in proper running condition.
- Fix damage to machine and replace any broken parts immediately.
- **ALWAYS** store equipment properly when it is not being used. Equipment should be stored in a clean, dry location out of the reach of children and unauthorized personnel

SAFETY INFORMATION

ENGINE SAFETY

DANGER

- The engine fuel exhaust gases contain poisonous carbon monoxide. This gas is colorless and odorless, and can cause death if inhaled.
- The engine of this equipment requires an adequate free flow of cooling air. **NEVER** operate this equipment in any enclosed or narrow area where free flow of the air is restricted. If the air flow is restricted it will cause injury to people and property and serious damage to the equipment or engine.



WARNING

- **DO NOT** place hands or fingers inside engine compartment when engine is running.
- **NEVER** operate the engine with heat shields or guards removed.
- Keep fingers, hands hair and clothing away from all moving parts to prevent injury.
- **DO NOT** remove the radiator cap while the engine is hot. High pressure boiling water will gush out of the radiator and severely scald any persons in the general area of the generator.
- **DO NOT** remove the coolant drain plug while the engine is hot. Hot coolant will gush out of the coolant tank and severely scald any persons in the general area of the generator.
- **DO NOT** remove the engine oil drain plug while the engine is hot. Hot oil will gush out of the oil tank and severely scald any persons in the general area of the generator.



CAUTION

- **NEVER** touch the hot exhaust manifold, muffler or cylinder. Allow these parts to cool before servicing equipment.



NOTICE

- **NEVER** run engine without an air filter or with a dirty air filter. Severe engine damage may occur. Service air filter frequently to prevent engine malfunction.
- **NEVER** tamper with the factory settings of the engine or engine governor. Damage to the engine or equipment can result if operating in speed ranges above the maximum allowable.
- Wet stacking is a common problem with diesel engines which are operated for extended periods with light or no load applied. When a diesel engine operates without sufficient load (less than 40% of the rated output), it will not operate at its optimum temperature. This will allow unburned fuel to accumulate in the exhaust system, which can foul the fuel injectors, engine valves and exhaust system, including turbochargers, and reduce the operating performance.



In order for a diesel engine to operate at peak efficiency, it must be able to provide fuel and air in the proper ratio and at a high enough engine temperature for the engine to completely burn all of the fuel.

Wet stacking does not usually cause any permanent damage and can be alleviated if additional load is applied to relieve the condition. It can reduce the system performance and increase maintenance. Applying an increasing load over a period of time until the excess fuel is burned off and the system capacity is reached usually can repair the condition. This can take several hours to burn off the accumulated unburned fuel.

- State Health Safety Codes and Public Resources Codes specify that in certain locations, spark arresters must be used on internal combustion engines that use hydrocarbon fuels. A spark arrester is a device designed to prevent accidental discharge of sparks or flames from the engine exhaust. Spark arresters are qualified and rated by the United States Forest Service for this purpose. In order to comply with local laws regarding spark arresters, consult the engine distributor or the local Health and Safety Administrator.

SAFETY INFORMATION

FUEL SAFETY

DANGER

- **DO NOT** start the engine near spilled fuel or combustible fluids. Diesel fuel is extremely flammable and its vapors can cause an explosion if ignited.
- **ALWAYS** refuel in a well-ventilated area, away from sparks and open flames.
- **ALWAYS** use extreme caution when working with **flammable** liquids.
- **DO NOT** fill the fuel tank while the engine is running or hot.
- **DO NOT** overfill tank, since spilled fuel could ignite if it comes into contact with hot engine parts or sparks from the ignition system.
- Store fuel in appropriate containers, in well-ventilated areas and away from sparks and flames.
- **NEVER** use fuel as a cleaning agent.
- **DO NOT** smoke around or near the equipment. Fire or explosion could result from fuel vapors or if fuel is spilled on a hot engine.



TOWING SAFETY

CAUTION

- Check with your local county or state safety towing regulations, in addition to meeting **Department of Transportation (DOT) Safety Towing Regulations**, before towing your generator.
- Refer to MQ Power trailer manual for additional safety information.
- In order to reduce the possibility of an accident while transporting the generator on public roads, **ALWAYS** make sure the trailer that supports the generator and the towing vehicle are mechanically sound and in good operating condition.
- **ALWAYS** shutdown engine before transporting



- Make sure the hitch and coupling of the towing vehicle are rated equal to, or greater than the trailer “gross vehicle weight rating.”
- **ALWAYS** inspect the hitch and coupling for wear. **NEVER** tow a trailer with defective hitches, couplings, chains, etc.
- Check the tire air pressure on both towing vehicle and trailer. **Trailer tires should be inflated to 50 psi cold.** Also check the tire tread wear on both vehicles.
- **ALWAYS** make sure the trailer is equipped with a **safety chain**.
- **ALWAYS** properly attach trailer’s safety chains to towing vehicle.
- **ALWAYS** make sure the vehicle and trailer directional, backup, brake and trailer lights are connected and working properly.
- DOT Requirements include the following:
 - Connect and test electric brake operation.
 - Secure portable power cables in cable tray with tie wraps.
- The maximum speed for highway towing is **55 MPH** unless posted otherwise. Recommended off-road towing is not to exceed **15 MPH** or less depending on type of terrain.
- Avoid sudden stops and starts. This can cause skidding, or jack-knifing. Smooth, gradual starts and stops will improve towing.
- Avoid sharp turns to prevent rolling.
- Trailer should be adjusted to a level position at all times when towing.
- Raise and lock trailer wheel stand in up position when towing.
- Place **chock blocks** underneath wheel to prevent **rolling** while parked.
- Place **support blocks** underneath the trailer’s bumper to prevent **tipping** while parked.
- Use the trailer’s swivel jack to adjust the trailer height to a level position while parked.

SAFETY INFORMATION

ELECTRICAL SAFETY

DANGER

- **DO NOT** touch output terminals during operation. Contact with output terminals during operation can cause **electrocution, electrical shock or burn.**

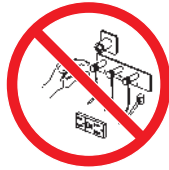

- The electrical voltage required to operate the generator can cause severe injury or even death through physical contact with live circuits. Turn generator and all circuit breakers **OFF** before performing maintenance on the generator or making contact with output terminals.

- **NEVER** insert any objects into the output receptacles during operation. This is extremely dangerous. The possibility exists of **electrical shock, electrocution or death.**



- Backfeed to a utility system can cause **electrocution** and/or property damage. **NEVER** connect the generator to a building's electrical system without a transfer switch or other approved device. All installations should be performed by a **licensed electrician** in accordance with all applicable laws and electrical codes. Failure to do so could result in electrical shock or burn, causing **serious injury or even death.**



Power Cord/Cable Safety

DANGER

- **NEVER** let power cords or cables **lay in water.**
- **NEVER stand in water** while AC power from the generator is being transferred to a load.
- **NEVER** use **damaged** or **worn** cables or cords when connecting equipment to generator. Inspect for cuts in the insulation.
- **NEVER** grab or touch a live power cord or cable with wet hands. The possibility exists of **electrical shock, electrocution or death.**

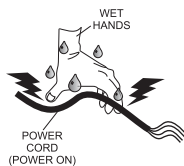

- Make sure power cables are securely connected to the generator's output receptacles. Incorrect connections may cause electrical shock and damage to the generator.

NOTICE

- **ALWAYS** make certain that proper power or extension cord has been selected for the job. See Cable Selection Chart in this manual.

Grounding Safety

DANGER

- **ALWAYS** make sure that electrical circuits are properly grounded to a suitable earth ground (ground rod) per the National Electrical Code (NEC) and local codes before operating generator. **Severe injury or death by electrocution** can result from operating an ungrounded generator.
- **NEVER** use gas piping as an electrical ground.

SAFETY INFORMATION

BATTERY SAFETY

DANGER

- **DO NOT** drop the battery. There is a possibility that the battery will explode.
- **DO NOT** expose the battery to open flames, sparks, cigarettes, etc. The battery contains combustible gases and liquids. If these gases and liquids come into contact with a flame or spark, an explosion could occur.



WARNING

- **ALWAYS** wear safety glasses when handling the battery to avoid eye irritation. The battery contains acids that can cause injury to the eyes and skin.
- Use well-insulated gloves when picking up the battery.
- **ALWAYS** keep the battery charged. If the battery is not charged, combustible gas will build up.
- **ALWAYS** recharge the battery in a well-ventilated environment to avoid the risk of a dangerous concentration of combustible gasses.
- If the battery liquid (dilute sulfuric acid) comes into contact with **clothing or skin**, rinse skin or clothing immediately with plenty of water.
- If the battery liquid (dilute sulfuric acid) comes into contact with **eyes**, rinse eyes immediately with plenty of water and contact the nearest doctor or hospital to seek medical attention.



CAUTION

- **ALWAYS** disconnect the **NEGATIVE** battery terminal before performing service on the generator.
- **ALWAYS** keep battery cables in good working condition. Repair or replace all worn cables.

ENVIRONMENTAL SAFETY

NOTICE

- Dispose of hazardous waste properly. Examples of potentially hazardous waste are used motor oil, fuel and fuel filters.
- **DO NOT** use food or plastic containers to dispose of hazardous waste.
- **DO NOT** pour waste, oil or fuel directly onto the ground, down a drain or into any water source.



SPECIFICATIONS

Table 1. Generator Specifications

Model	DCA-125SSIU	
Type	Revolving field, self ventilated, open protected type synchronous generator	
Armature Connection	Star with Neutral	Zigzag
Phase	3	Single
Standby Output	110 KW (137.5 kVA)	79 KW
Prime Output	100 KW (125 kVA)	72 KW
3Ø Voltage (L-L/L-N) Voltage Selector Switch at 3Ø 240/139	208Y/120, 220Y/127, 240Y/139	N/A
3Ø Voltage (L-L/L-N) Voltage Selector Switch at 3Ø 480/277	416Y/240, 440Y/254, 480Y/277	N/A
1Ø Voltage (L-L/L-N) Voltage Selector Switch at 1Ø 240/120	N/A	240/120
Power Factor	0.8	1.0
Frequency	60 Hz	
Speed	1800 rpm	
Aux. AC Power	Single Phase, 60 Hz	
Aux. Voltage/Output	4.8 Kw (2.4 kW x 2)	
Dry Weight	4,609 lbs. (2,090 kg.)	
Wet Weight	5,182 lbs. (2,350 kg.)	

Table 2. Engine Specifications

Model	ISUZU 4HK1X	
Type	4 cycle, water-cooled, direct injection, turbo-charged with charged air-cooled	
No. of Cylinders	4 cylinders	
Bore x Stroke	4.53 in. x 4.92 in. (115 mm x 125 mm)	
Displacement	317 cu. in. (5,193 cc)	
Rated Output	152 HP at 1800 rpm	
Starting	Electric	
Coolant Capacity	5.30 gal. (20.2 liters)	
Lube Oil Capacity	5.99 gal. (22.7 liters)	
Fuel Type	#2 Diesel Fuel	
Fuel Tank Capacity	63 gal. (240 liters)	
Fuel Consumption	7.3 gal. (27.6 L)/hr at full load	5.7 gal. (21.7 L)/hr at 3/4 load
	4.1 gal. (15.4 L)/hr at 1/2 load	2.5 gal. (9.5 L)/hr at 1/4 load
Battery	12V-128 Ah x 1	

DIMENSIONS

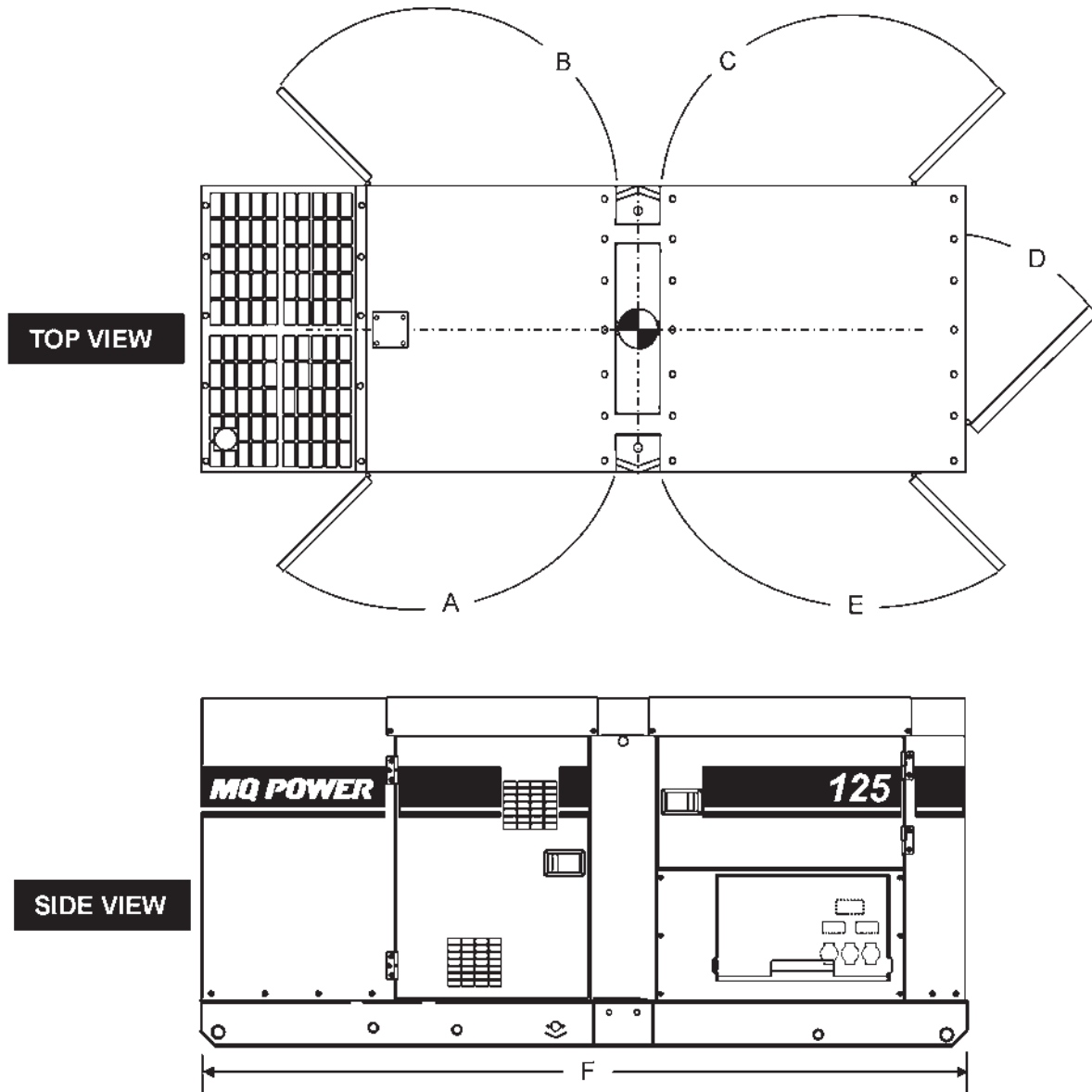

Figure 1. Dimensions

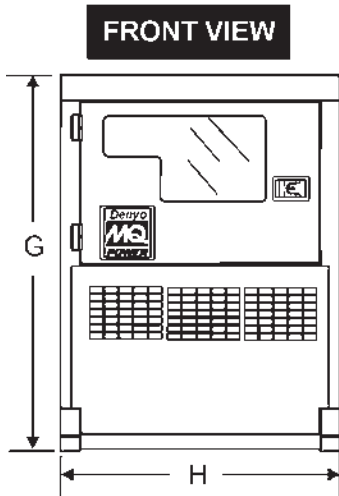

Table 3. Dimensions			
Reference Letter	Dimension in. (mm)	Reference Letter	Dimension in. (mm)
A	34.76 in. (883 mm.)	F	120 in. (3,050 mm.)
B	34.76 in. (883 mm.)	G	55.11 in. (1,400 mm.)
C	37.20 in. (945 mm.)	H	43.30 in. (1,100 mm.)
D	38.18 in. (970 mm.)		
E	37.20 in. (945 mm.)		

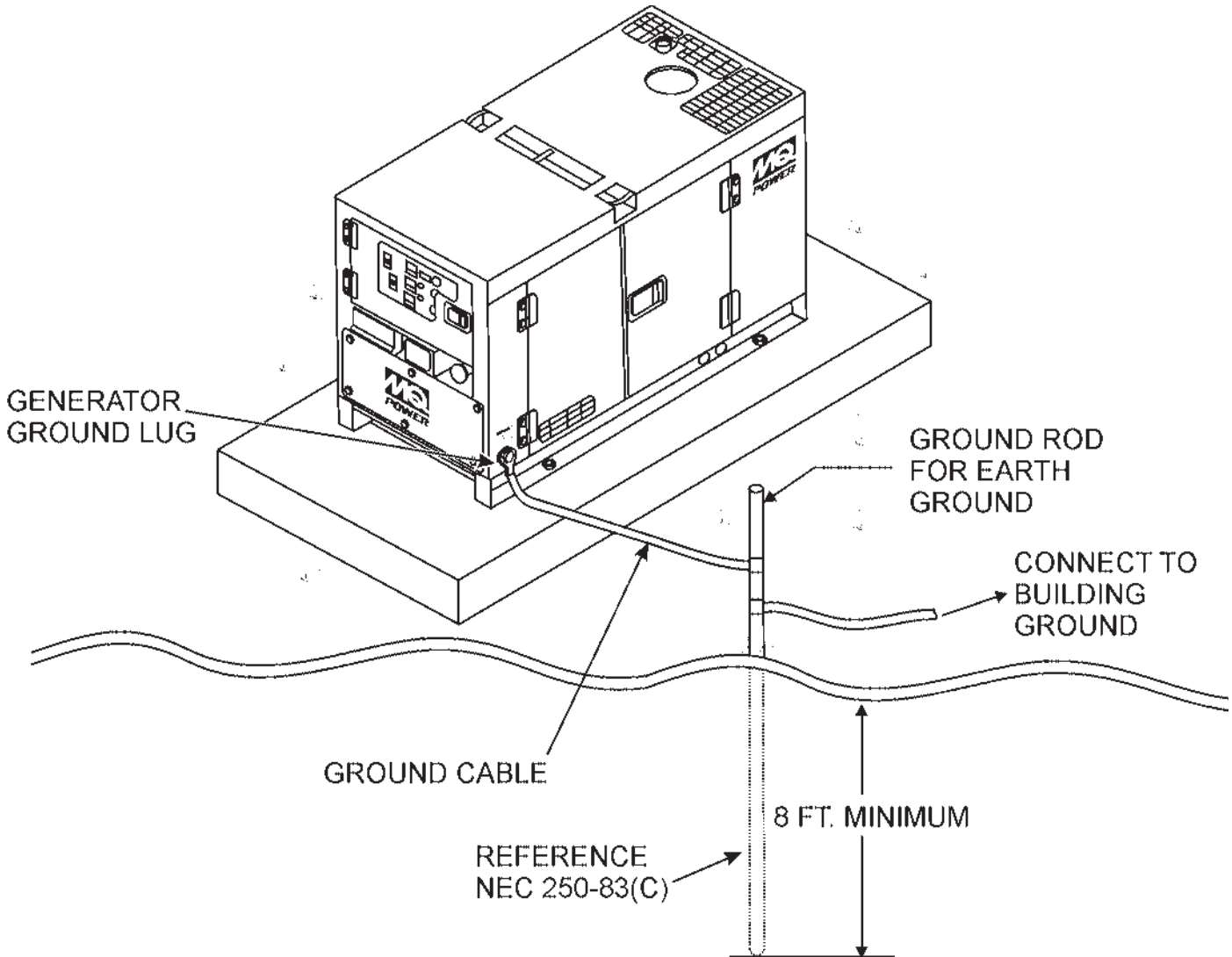

Figure 2. Typical Generator Grounding Application

OUTDOOR INSTALLATION

Install the generator in a area that is free of debris, bystanders, and overhead obstructions. Make sure the generator is on secure level ground so that it cannot slide or shift around. Also install the generator in a manner so that the exhaust will not be discharged in the direction of nearby homes.

The installation site must be relatively free from moisture and dust. All electrical equipment should be protected from excessive moisture. Failure to do will result in deterioration of the insulation and will result in short circuits and grounding.

Foreign materials such as dust, sand, lint and abrasive materials have a tendency to cause excessive wear to engine and alternator parts.

CAUTION

Pay close attention to ventilation when operating the generator inside tunnels and caves. The engine exhaust contains noxious elements. Engine exhaust must be routed to a ventilated area.

INDOOR INSTALLATION

Exhaust gases from diesel engines are extremely poisonous. Whenever an engine is installed indoors the exhaust fumes must be vented to the outside. The engine should be installed at least two feet from any outside wall. Using an exhaust pipe which is too long or too small can cause excessive back pressure which will cause the engine to heat excessively and possibly burn the valves.

MOUNTING

The generator must be mounted on a solid foundation (such as concrete) and set firmly on the foundation to isolate vibration of the generator when it is running. The generator must set at least 6 inches above the floor or grade level (in accordance to NFPA 110, Chapter 5-4.1). **DO NOT** remove the metal skids on the bottom of the generator. They are to resist damage to the bottom of the generator and to maintain alignment.

GENERATOR GROUNDING

To guard against electrical shock and possible damage to the equipment, it is important to provide a good **EARTH** ground.

Article 250 (Grounding) of the National Electrical Code (NEC) provides guide lines for proper grounding and specifies that the cable ground shall be connected to the grounding system of the building as close to the point of cable entry as practical.

NEC articles 250-64(b) and 250-66 set the following grounding requirements:

1. Use one of the following wire types to connect the generator to earth ground.
 - a. Copper - 8 AWG (5.3 mm²)
 - b. Aluminum - 6 AWG (8.4 mm²)
2. When grounding the generator (Figure 2) connect the ground cable between the lock washer and the nut on the generator and tighten the nut fully. Connect the other end of the ground cable to earth ground.
3. NEC article 250-52(c) specifies that the earth ground rod should be buried a minimum of 8 ft. into the ground.

NOTICE

When connecting the generator to any buildings electrical system **ALWAYS** consult with a licensed electrician.

GENERAL INFORMATION

GENERATOR

The MQ Power Model DCA125SSIU generator (Figure 3) is a high quality portable (requires a trailer for transport) power source for telecom sites, lighting facilities, power tools, submersible pumps and other industrial and construction machinery.

ENGINE OPERATING PANEL

The “Engine Operating Panel” is provided with the following:

- Tachometer
- Water Temperature Gauge
- Oil Pressure Gauge
- Charging Ammeter Gauge
- Fuel Level Gauge
- Engine Speed Switch
- Auto START/STOP Engine Controller (ECU)
- Panel Light/Panel Light Switch
- Pre-Heat Lamp
- Warning Lamp

GENERATOR CONTROL PANEL

The “Generator Control Panel” is provided with the following:

- Frequency Meter (Hz)
- AC Ammeter (Amps)
- AC Voltmeter (Volts)
- Ammeter Change-Over Switch
- Voltmeter Change-Over Switch
- Voltage Regulator
- 3-Pole, 300 amp Main Circuit Breaker
- “Control Box” (located behind the Gen. Control Panel)
 - Automatic Voltage Regulator
 - Current Transformer
 - Over-Current Relay
 - Starter Relay
 - Engine Controller (Computer Controlled)
 - Voltage Selector Switch

OUTPUT TERMINAL PANEL

The “Output Terminal Panel” is provided with the following:

- Three 120/240V output receptacles (CS-6369), 50A
- Three auxiliary circuit breakers, 50A
- Two 120V output receptacles (GFCI), 20A
- Two GFCI circuit breakers, 20A
- Five output terminal lugs (3Ø power)
- Battery Charger (Optional)
- Water Heater (Optional)

OPEN DELTA EXCITATION SYSTEM

The DCA125SSIU generator is equipped with the state of the art “Open-Delta” excitation system. The open delta system consist of an electrically independent winding wound among stationary windings of the AC output section.

There are four connections of the open delta A, B, C and D. During steady state loads, the power from the voltage regulator is supplied from the parallel connections of A to B, A to D, and C to D. These three phases of the voltage input to the voltage regulator are then rectified and are the excitation current for the exciter section.

When a heavy load, such as a motor starting or a short circuit occurs, the automatic voltage regulator (AVR) switches the configuration of the open delta to the series connection of B to C. This has the effect of adding the voltages of each phase to provide higher excitation to the exciter section and thus better voltage response during the application of heavy loads.

The connections of the AVR to the AC output windings are for sensing only. No power is required from these windings.

The open-delta design provides virtually unlimited excitation current, offering maximum motor starting capabilities. The excitation does not have a “fixed ceiling” and responds according the demands of the required load.

ENGINE

The DCA125SSIU is powered by a 4 cylinder, water cooled, direct injection, turbocharged air-to-air intercooled ISUZU 4HK1X diesel engine. This engine is designed to meet every performance requirement for the generator. Reference Table 2 for engine specifications.

In keeping with MQ Power’s policy of constantly improving its products, the specifications quoted herein are subject to change without prior notice.

ELECTRIC GOVERNOR SYSTEM

The electric governor system controls the RPMs of the engine. When the engine demand increases or decreases, the governor system regulates the frequency variation to $\pm 0.25\%$.

EXTENSION CABLES

When electric power is to be provided to various tools or loads at some distance from the generator, extension cords are normally used. Cables should be sized to allow for distance in length and amperage so that the voltage drop between the generator and point of use (load) is held to a minimum. Use the cable selection chart (Table 6) as a guide for selecting proper extension cable size.

MAJOR COMPONENTS

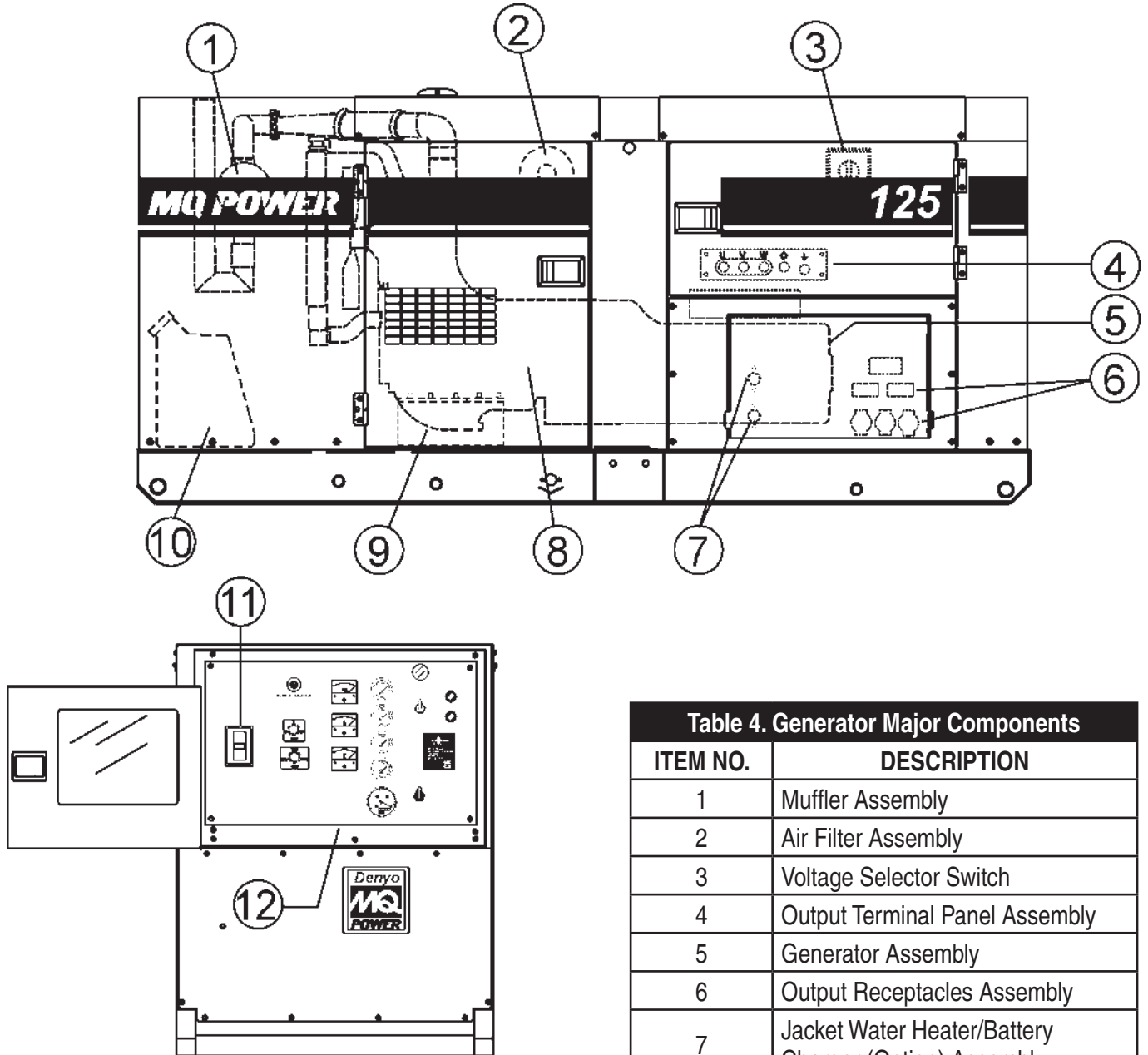

Table 4. Generator Major Components	
ITEM NO.	DESCRIPTION
1	Muffler Assembly
2	Air Filter Assembly
3	Voltage Selector Switch
4	Output Terminal Panel Assembly
5	Generator Assembly
6	Output Receptacles Assembly
7	Jacket Water Heater/Battery Charger (Option) Assembly
8	Engine Assembly
9	Battery Assembly
10	Fuel Tank Assembly
11	Main Circuit Breaker Assembly
12	Generator/Engine Operating Panel Assembly

Figure 3. Major Components

GENERATOR CONTROL PANEL

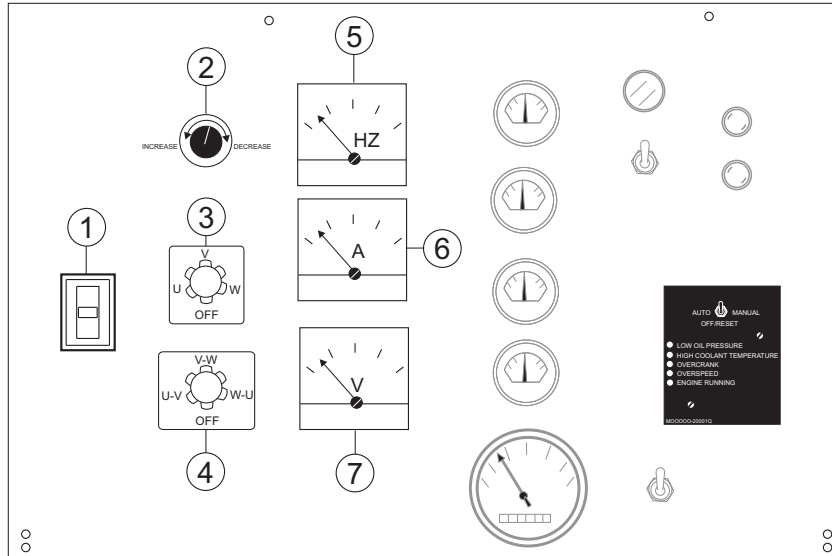

Figure 4. Generator Control Panel

The definitions below describe the controls and functions of the DCA125SSIU Generator Control Panel (Figure 4).

1. **Main Circuit Breaker**—This three-pole, 300A main breaker is provided to protect the the U,V, and W Output Terminal Lugs from overload.
2. **Voltage Regulator Control** — Allows $\pm 15\%$ manual adjustment of the generator's output voltage.
3. **Ammeter Change-Over Switch** — This switch allows the AC ammeter to indicate the current flowing to the load connected to any phase of the output terminals, or to be switched off. This switch does not effect the generator output in any fashion, it is for current reading only.
4. **Voltmeter Change-Over Switch** — This switch allows the AC voltmeter to indicate phase to phase voltage between any two phases of the output terminals or to be switched off.
5. **Frequency Meter** — Indicates the output frequency in hertz (Hz). Normally 60 Hz.
6. **AC Ammeter** — Indicates the amount of current the load is drawing from the generator per leg selected by the ammeter phase-selector switch.
7. **AC Voltmeter** — Indicates the output voltage present at the U,V, and W Output Terminal Lugs.

Located behind the generator control panel is the Generator Control Box. This box contains some of the necessary electronic components required to make the generator function.

The Control Box is equipped with the following major components:

- Over-Current Relay
- Automatic Voltage Regulator (AVR)
- Starter Relay
- Current Transformer
- Voltage Selector Switch
- Main Circuit Breaker

NOTICE

Remember the **overcurrent relay** monitors the current flowing from the **U,V, and W Output Terminal Lugs** to the load.

In the event of a short circuit or over current condition, it will automatically trip the 300 amp main breaker.

To restore power to the **Output Terminal Panel**, press the reset button on the overcurrent relay and place the **main circuit breaker** in the **closed** position (**ON**).

ENGINE OPERATING PANEL

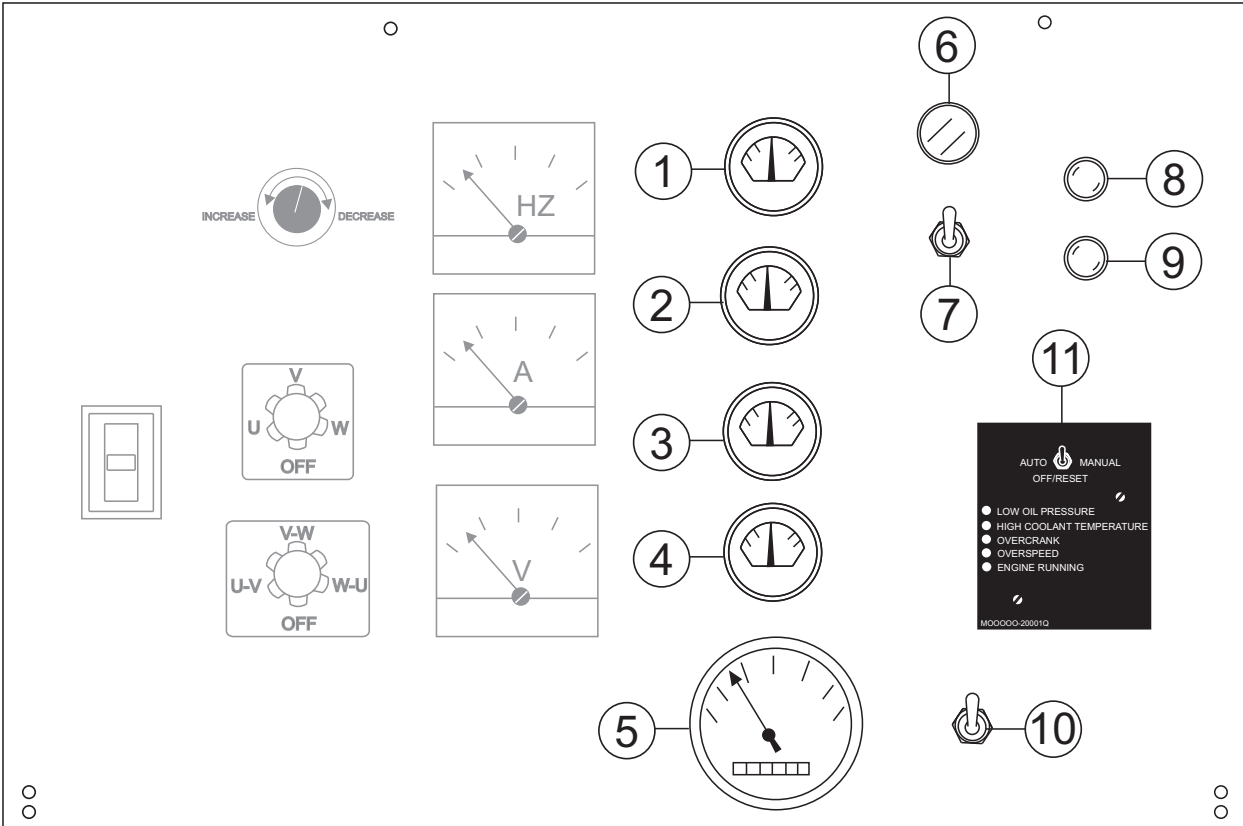

Figure 5. Engine Operating Panel

ENGINE OPERATING PANEL

The definitions below describe the controls and functions of the DCA-125SSIU Engine Operating Panel (Figure 5).

1. **Oil Pressure Gauge** — During normal operation this gauge should read between 42 ~71 psi. (290~490 kPa). When starting the generator the oil pressure may read a little higher, but after the engine warms up the oil pressure should return to the correct pressure range.
2. **Fuel Gauge** — Indicates amount of diesel fuel available.
3. **Charging Ammeter Gauge** — Indicates the current being supplied by the engine's alternator which provides current for generator's control circuits and battery charging system.
4. **Water Temperature Gauge** — During normal operation this gauge should read between 167°~203°F (75°~95°C)
5. **Tachometer** — Indicates engine speed in RPM's for 60 Hz operation. This meter should indicate 1800 RPM's when the rated load is applied. In addition a built in hour meter will record the number of operational hours that the generator has been in use.
6. **Panel Light** — Normally used in dark areas or at night time. When activated, panel lights will illuminate. When the generator is not in use be sure to turn the panel light switch to the OFF position.
7. **Panel Light Switch** — When activated will turn on control panel light.
8. **Pre-Heat Lamp** — As the engine cranks, this lamp will illuminate to indicate automatic preheating of the engine glow plugs. When the lamp turns off, this indicates that the preheat cycle is complete and the engine will start automatically.
9. **Warning Lamp** — Indicates that a failure has occurred in the engine control system.
10. **Engine Speed Switch** — This switch controls the speed
11. **Auto START/STOP Engine Controller (ECU)** — This controller has a vertical row of status LED's (inset), that when lit, indicate that an engine malfunction (fault) has been detected. When a fault has been detected the engine controller will evaluate the fault and all major faults will shutdown the generator. During cranking cycle, the ECU will attempt to crank the engine for 10 seconds before disengaging.



If the engine does not engage (start) by the third attempt, the engine will be shutdown by the engine controller's Over Crank Protection mode. If the engine engages at a speed (RPM's) that is not safe, the controller will shutdown the engine by initializing the Over Speed Protection mode.

Also the engine controller will shut down the engine in the event of low oil pressure, high coolant temperature, low coolant level, and loss of magnetic pickup. These conditions can be observed by monitoring the LED status indicators on the front of the controller module.

- A. **MPEC Control Switch** — This switch controls the running of the unit. If this switch is set to the OFF/RESET position, the unit will not run. When this switch is set to the manual position, the generator will start immediately.

If the generator is to be connected to a building's AC power source via an automatic transfer switch (isolation), place the switch in the AUTO position. In this position, should an outage occur, the automatic transfer switch (ATS) will start the generator automatically via the generator's auto-start contacts connected to the ATS's start contacts. Please refer to your ATS installation manual for further instructions for the correct installation of the auto-start contacts of the generator to the ATS.

- B. **Low Oil Pressure** — Indicates the engine pressure has fallen below 15 psi (103 kPa). The oil pressure is detected using variable resistive values from the oil pressure sending unit. This is considered a major fault.
- C. **High Coolant Temperature** — Indicates the engine temperature has exceeded 230°F (110°C). The engine temperature is detected using variable resistive values from the temperature sending unit. This is considered a major fault.
- D. **Overcrank Shutdown** — Indicates the unit has attempted to start a pre-programmed number of times, and has failed to start. The number of cycles and duration are programmable. It is pre-set at 3 cycles with a 10 second duration. This is considered a major fault.
- E. **Overspeed Shutdown** — Indicates the engine is running at an unsafe speed. This is considered a major fault.
- F. **Engine Running** — Indicates that engine is running at a safe operating speed.

OUTPUT TERMINAL PANEL FAMILIARIZATION

OUTPUT TERMINAL PANEL

The Output Terminal Panel (Figure 6) shown below is located on the right-hand side (left from control panel) of the generator. Lift up on the cover to gain access to receptacles and terminal lugs.

NOTICE

Terminal legs "O" and "Ground" are considered bonded grounds.

OUTPUT TERMINAL FAMILIARIZATION

The "Output Terminal Panel" (Figure 6) is provided with the following:

- Three (3) 120/240V output receptacles @ 50 amp
- Three (3) Circuit Breakers @ 50 amps
- Two (2) 120V GFCI receptacles @ 20 amp
- Two (2) GFCI Circuit Breakers @ 20 amps
- Eight (8) Output Terminal Lugs (U, V, W, O, Ground)

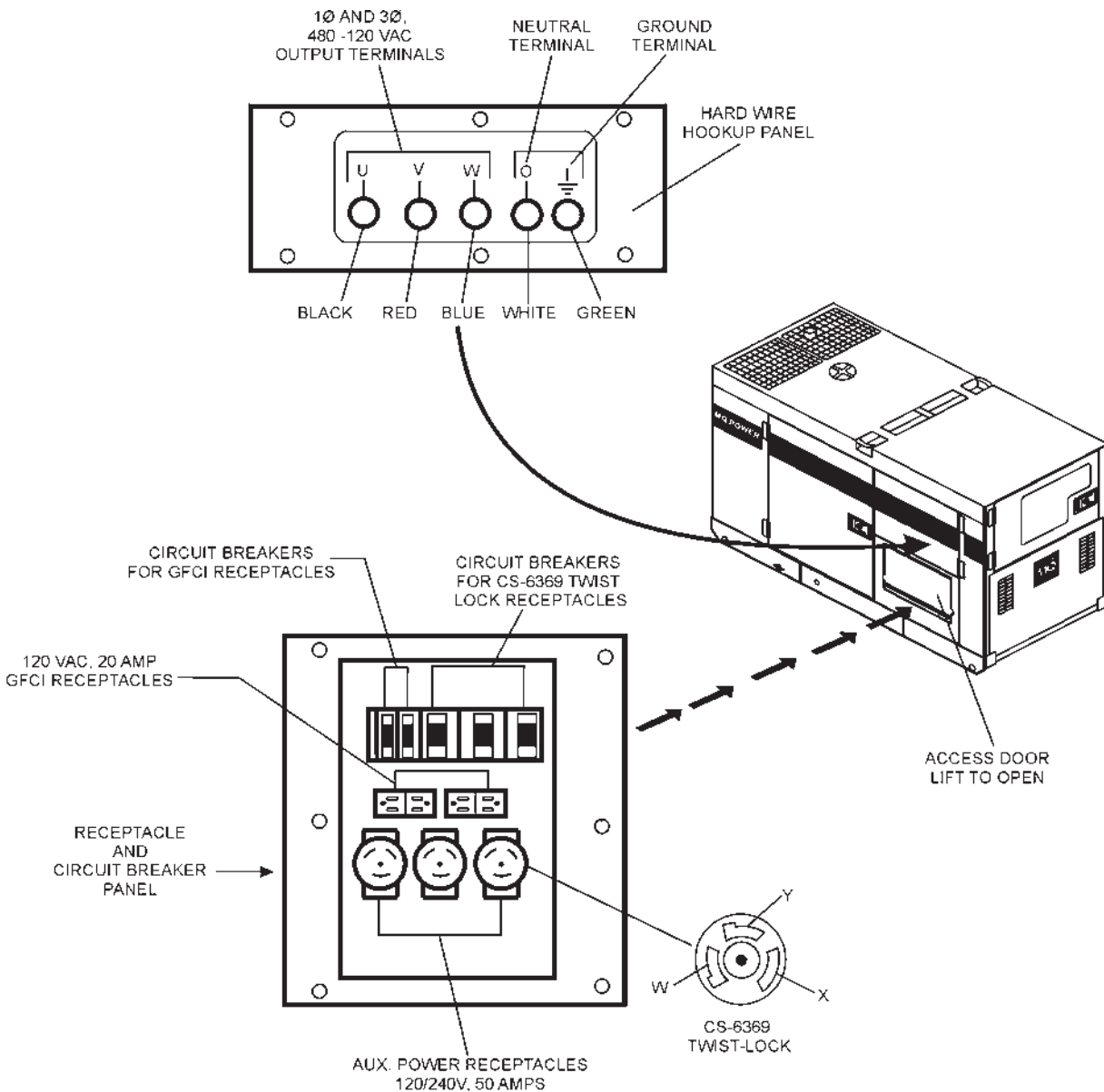

Figure 6. Output Terminal Panel

OUTPUT TERMINAL PANEL FAMILIARIZATION

120 VAC GFCI Receptacles

There are two 120 VAC, 20 amp GFCI (Duplex Nema 5-20R) receptacles provided on the output terminal panel. These receptacles can be accessed in **any voltage selector switch** position. Each receptacle is protected by a 20 amp circuit breaker. These breakers are located directly above the GFCI receptacles. Remember the load output (current) of both GFCI receptacles is dependent on the load requirements of the U, V, and W output terminal lugs.

Pressing the **reset** button resets the GFCI receptacle after being tripped. Pressing the **test button** (See Figure 7) in the center of the receptacle will check the GFCI function. Both receptacles should be tested at least once a month.

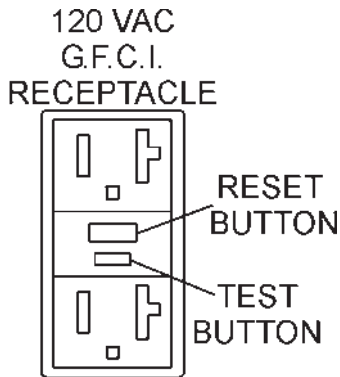

Figure 7. G.F.C.I. Receptacle

Twist Lock Dual Voltage 120/240 VAC Receptacles

There are three 120/240V, 50 amp auxiliary twist-lock (CS-6369) receptacles (Figure 8) provided on the output terminal panel. These receptacles can **only** be accessed when the voltage selector switch is placed in the **single-phase 240/120 position**.

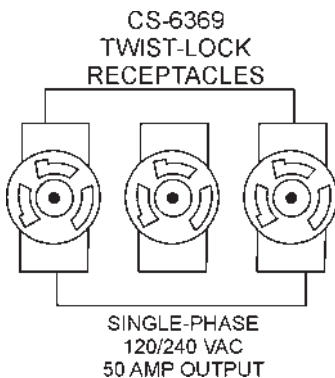

Figure 8. 120/240V Twist-Lock Auxiliary Receptacles

Each auxiliary receptacle is protected by a 50 amp circuit breaker. These breakers are located directly above the GFCI receptacles. Remember the load output (current) on all three receptacles is dependent on the load requirements of the **Output Terminal Lugs**.

Turn the **voltage regulator control knob** (Figure 9) on the control panel to obtain the desired voltage. Turning the knob clockwise will **increase** the voltage, turning the knob counter-clockwise will **decrease** the voltage.



Figure 9. Voltage Regulator Control Knob

OUTPUT TERMINAL PANEL FAMILIARIZATION

Connecting Loads

Loads can be connected to the generator by the **Output Terminal Lugs** or the convenience receptacles (Figure 10). Make sure to read the operation manual before attempting to connect a load to the generator.

To protect the output terminals from overload, a 3-pole, 300A **main** circuit breaker is provided. Make sure to switch **ALL** circuit breakers to the **OFF** position prior to starting the engine.

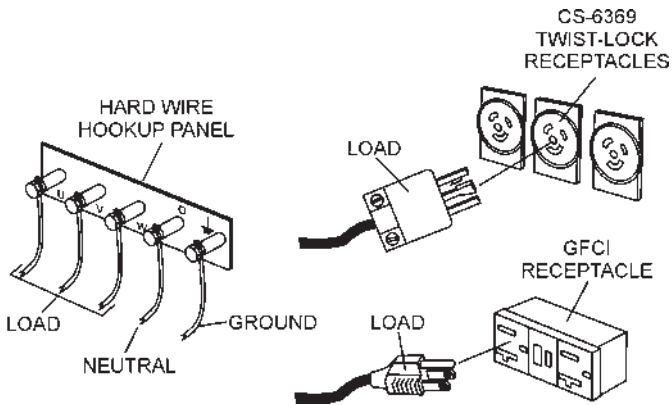

Figure 10. Connecting Loads

Over Current Relay

An **over current relay** (Figure 11) is connected to the main circuit breaker. In the event of an overload, both the circuit breaker and the over current relay may trip. If the circuit breaker can not be reset, the **reset button** on the over current relay must be pressed. The over current relay is located in the control box.

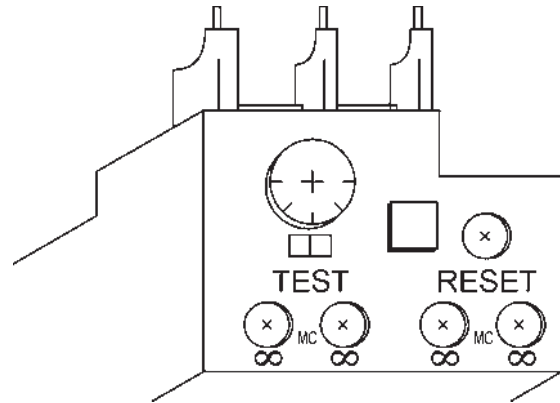

Figure 11. Over Current Relay

LOAD APPLICATION

SINGLE PHASE LOAD

Always be sure to check the nameplate on the generator and equipment to insure the wattage, amperage, frequency, and voltage requirements are satisfactorily supplied by the generator for operating the equipment.

Generally, the wattage listed on the nameplate of the equipment is its rated output. Equipment may require 130—150% more wattage than the rating on the nameplate, as the wattage is influenced by the efficiency, power factor and starting system of the equipment.

NOTICE

If wattage is not given on the equipment's name plate, approximate wattage may be determined by multiplying nameplate voltage by the nameplate amperage.

$$\text{WATTS} = \text{VOLTAGE} \times \text{AMPERAGE}$$

The power factor of this generator is 0.8. See Table 5 below when connecting loads.

Table 5. Power Factor By Load

Type of Load	Power Factor
Single-phase induction motors	0.4-0.75
Electric heaters, incandescent lamps	1.0
Fluorescent lamps, mercury lamps	0.4-0.9
Electronic devices, communication equipment	1.0
Common power tools	0.8

Table 6. Cable Selection (60 Hz, Single Phase Operation)

Current in Amperes	Load in Watts		Maximum Allowable Cable Length			
	At 100 Volts	At 200 Volts	#10 Wire	#12 Wire	#14 Wire	#16 Wire
2.5	300	600	1000 ft.	600 ft.	375 ft.	250 ft.
5	600	1200	500 ft.	300 ft.	200 ft.	125 ft.
7.5	900	1800	350 ft.	200 ft.	125 ft.	100 ft.
10	1200	2400	250 ft.	150 ft.	100 ft.	
15	1800	3600	150 ft.	100 ft.	65 ft.	
20	2400	4800	125 ft.	75 ft.	50 ft.	

CAUTION: Equipment damage can result from low voltage

THREE PHASE LOAD

When calculating the power requirements for 3-phase power use the following equation:

$$\text{KVA} = \frac{\text{VOLTAGE} \times \text{AMPERAGE} \times 1.732}{1000}$$

NOTICE

If 3Ø load (kVA) is not given on the equipment nameplate, approximate 3Ø load may be determined by multiplying voltage by amperage by 1.732.

NOTICE

Motors and motor-driven equipment draw much greater current for starting than during operation.

An inadequate size connecting cable which cannot carry the required load can cause a voltage drop which can burn out the appliance or tool and overheat the cable. See Table 6.

- When connecting a resistance load such as an incandescent lamp or electric heater, a capacity of up to the generating set's rated output (kW) can be used.
- When connecting a fluorescent or mercury lamp, a capacity of up to the generating set's rated output (kW) multiplied by 0.6 can be used.
- When connecting an electric drill or other power tools, pay close attention to the required starting current capacity.

When connecting ordinary power tools, a capacity of up to the generating set's rated output (kW) multiplied by 0.8 can be used.

DANGER

Before connecting this generator to any building's electrical system, a **licensed electrician** must install an **isolation (transfer) switch**. Serious damage to the building's electrical system may occur without this transfer switch.

GENERATOR OUTPUTS

GENERATOR OUTPUT VOLTAGES

A wide range of voltages are available to supply voltage for many different applications. Voltages are selected by using the **voltage selector** switch (Figure 12). To obtain some of the voltages as listed in Table 7 (see below) will require a fine adjustment using the **voltage regulator (VR) control knob** located on the control panel.

Voltage Selector Switch

The voltage selector switch (Figure 12) is located above the output terminal panel's Hard Wire Hook-up Panel. It has been provided for ease of voltage selection.

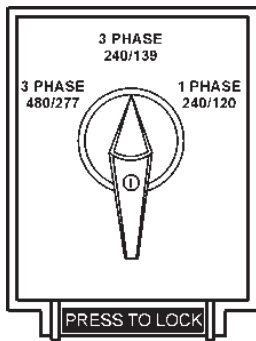

Figure 12. Voltage Change-Over Board

Voltage Selector Switch Locking Button

To lock the voltage selector switch, **press and hold the red button** located at the bottom of the switch. While holding the red button down, insert a pad lock into the hole next to the button to retain it in the inward locked position. When the lock is removed, the red button is spring loaded and will return to its normal outward unlocked position switch.

CAUTION

NEVER change the position of the **voltage selector switch** while the engine is running. **ALWAYS** place circuit breaker in the **OFF** position before selecting voltage.

Table 7. Voltages Available

UVWO Output Terminal Lugs	Voltage Selector Switch 3-Phase 240/139V Position			Voltage Selector Switch 3-Phase 480/270V Position		
	208V	220V	240V	416V	440V	480V
3Ø Line-Line						
1Ø Line-Neutral	120V	127V	139V	240V	254V	277V
Voltage Selector Switch Single-Phase 240/120V Position						
1Ø Line-Neutral/ Line-Line	120V Line-Neutral	N/A	N/A	240V Line-Line	N/A	N/A

Maximum Amps

Table 8 shows the **maximum** amps the generator can provide. **DO NOT** exceed the maximum amps as listed..

Table 8. Generator Maximum Amps

Rated Voltage	Maximum Amps
Voltage Selector Switch 1Ø 240/120 position (120V)	277.8 Amps (4 wire) 301A X 2 (Zigzag)
Voltage Selector Switch 1Ø 240/120 position (240V)	138.9 Amps (4 wire) 301A (Zigzag)
Voltage Selector Switch 3Ø 240/139 position (240V)	301 Amps
Voltage Selector Switch 3Ø 480/277 position (480V)	150 Amps

GFCI Receptacle Load Capability

The load capability of the GFCI receptacles is directly related to the voltage being supplied at either the output terminals or the two twist-lock auxiliary receptacles.

Tables 9 and 10 show what amount of current is available at the GFCI receptacles when the output terminals and twist lock receptacles are in use. Be careful that your load does not to exceed the available current capability at the receptacles.

Table 9. GFCI Receptacle Load Capability

KW in use Twist-Lock (CS6369)	Available Load Current (Amps)
1Ø 240/120V	GFCI Duplex NEMA 5-20R 120V
72.0	0 amps per receptacle
70.8	5 amps per receptacle
69.6	10 amps per receptacle
68.4	15 amps per receptacle
67.2	20 amps per receptacle

Table 10. GFCI Receptacle Load Capability

KVA in use (UVWO Terminals)	Available Load Current (Amps)
3Ø 240/480V	GFCI Duplex NEMA 5-20R 120V
125	0 amps per receptacle
121	5 amps per receptacle
117	10 amps per receptacle
113	15 amps per receptacle
108	20 amps per receptacle

GENERATOR OUTPUTS/GAUGE READING

HOW TO READ THE OUTPUT TERMINAL GAUGE

The AC ammeter and AC voltmeter change-over switches on the control panel **DO NOT** effect the generator output. They are provided to help observe how much power is being supplied, produced at the UVWO terminals lugs.

Before taking a reading from either gauge, set the **Voltage Selector Switch** (Figure 13) to the position which produces the required voltage (For example, for 3 \emptyset 240V, choose the center 3 \emptyset 240/139V position on the voltage selector switch.)

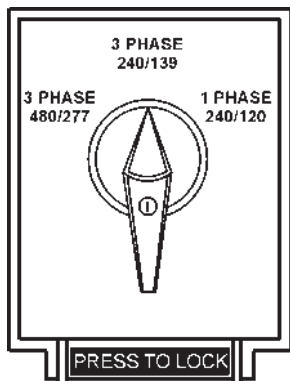

Figure 13. Voltage Selector Switch
240/139V 3 \emptyset Positio

NOTICE

For 3 \emptyset 208V/1 \emptyset ,120V, place the Voltage Selector Switch in the 3 Phase 340/139 position.

Reading Amperage

To determine the amperage at a terminal lug, set the **AC Ammeter Change-Over Switch** to the appropriate setting (Figure 16) to activate the AC Ammeter Gauge (Figure 17) and read the available amperage at the terminal lug.

For example, to measure the amperage at the U terminal lug, set the **AC Ammeter Change-Over Switch** to U and read the **AC Ammeter Gauge**.

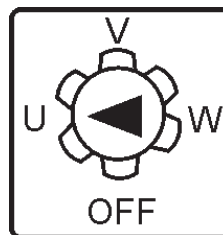

Figure 16. AC Ammeter Change-Over Switch

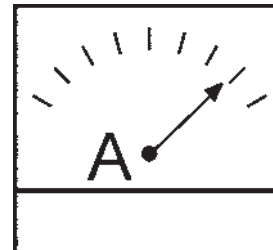

Figure 17. AC Ammeter (Amp Reading on U Lug)

NOTICE

The *ammeter* gauge will only show a reading when the **Output Terminal Lugs** are connected to a load and in use.

Reading Voltage

To determine the voltage between two terminal lugs, set the **AC Voltmeter Change-Over Switch** to the appropriate setting (Figure 14) to activate the **AC Voltmeter Gauge** (Figure 15) and read the available voltage between the two lugs.

For example, to measure the voltage between the W and U terminal lugs, set the **AC Voltmeter Change-Over Switch** to W-U and read the **AC Voltmeter Gauge**.

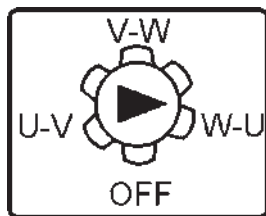

Figure 14. AC Voltmeter Change-Over Switch

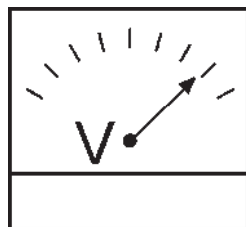

Figure 15. AC Voltmeter Gauge

OUTPUT TERMINAL PANEL CONNECTIONS

UVWO TERMINAL OUTPUT VOLTAGES

Various output voltages can be obtained using the UVWO output terminal lugs. The voltages at the terminals are dependent on the position of the **Voltage Selector Switch** and the adjustment of the **Voltage Regulator Control Knob**.

Remember the voltage selector switch determines the **range** of the output voltage. The voltage regulator (VR) allows the user to increase or decrease the selected voltage.

3Ø-240/139 UVWO Terminal Output Voltages

1. Place the voltage selector switch in the 3Ø 240/139 position as shown in Figure 18..

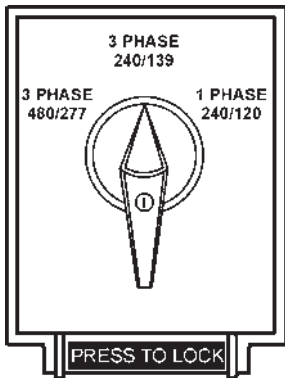

**Figure 18. Voltage Selector Switch
3Ø-240/139V Position**

2. Connect the load wires to the UVWO terminals as shown in Figure 19.

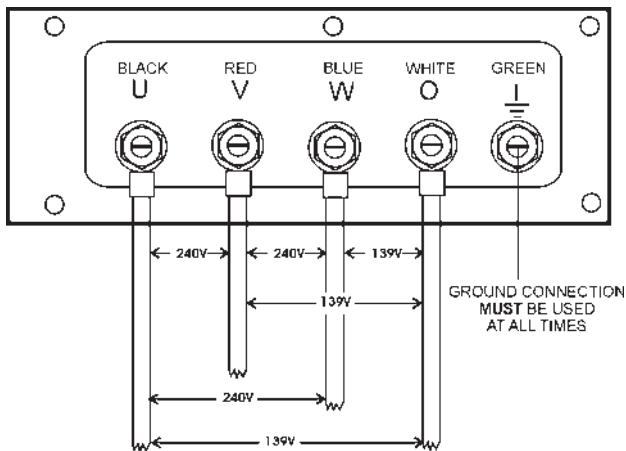

**Figure 19. UVWO Terminal Lugs
3Ø-240/139V Connections**

3. Turn the voltage regulator knob (Figure 20) clockwise to increase voltage output, turn counterclockwise to decrease voltage output. Use voltage regulator adjustment knob whenever fine tuning of the output voltage is required.



Figure 20. Voltage Regulator Knob

3Ø-208V/1Ø-120V UVWO Terminal Output Voltages

1. Place the voltage selector switch in the 3Ø 240/139 position as shown in Figure 21.

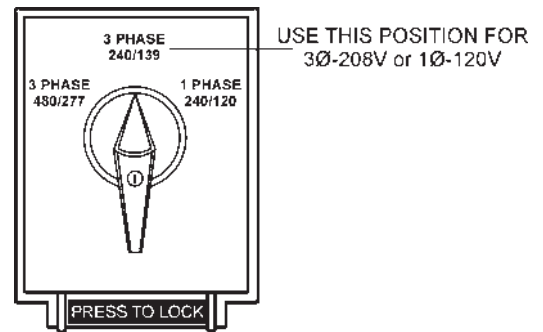

**Figure 21. Voltage Selector Switch
3Ø-240/139V Position**

2. Connect the load wires to the UVWO terminals as shown in Figure 22.

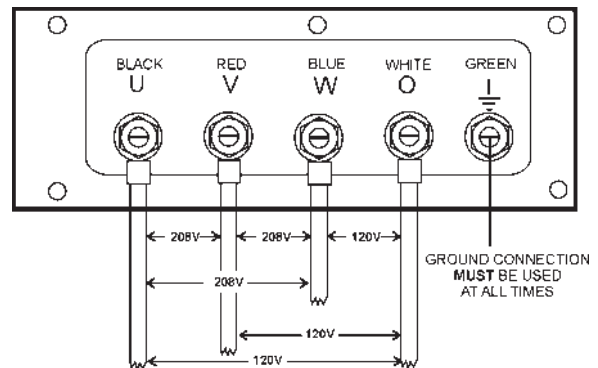

**Figure 22. UVWO Terminal Lugs
3Ø-208/1Ø-120V Connections**

NOTICE

To achieve a 3Ø 208V output the voltage selector switch must be in the 3Ø-240/139 position and the voltage regulator must be adjusted to 208V..

OUTPUT TERMINAL PANEL CONNECTIONS

3Ø-480/277V UVWO Terminal Output Voltages

1. Place the voltage selector switch in the 3Ø 480/277 position as shown in Figure 23.

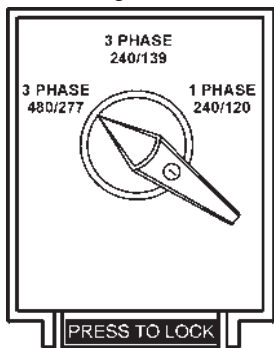

**Figure 23. Voltage Selector Switch
3Ø-480/277V Position**

2. Connect the load wires to the UVWO terminals as shown in Figure 24.

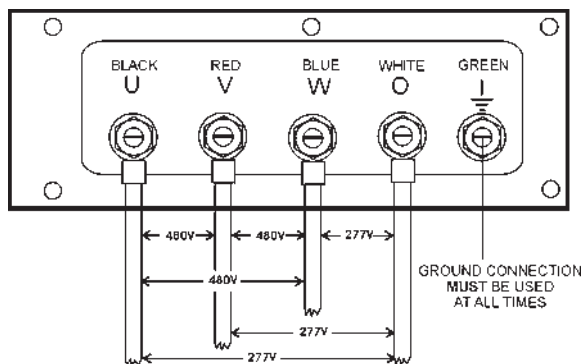
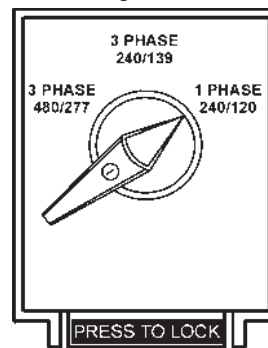

**Figure 24. UVWO Terminal Lugs
3Ø-480/277V Connections**

3. Turn the voltage regulator knob (Figure 20) clockwise to increase voltage output, turn counterclockwise to decrease voltage output. Use voltage regulator adjustment knob whenever fine tuning of the output voltage is required.

1Ø-240/120V UVWO Terminal Output Voltages

1. Place the voltage selector switch in the 1Ø 240/120 position as shown in Figure 25.



**Figure 25. Voltage Selector Switch
1Ø-240/120V Position**

2. Connect the load wires to the UVWO terminals as shown in Figure 26.

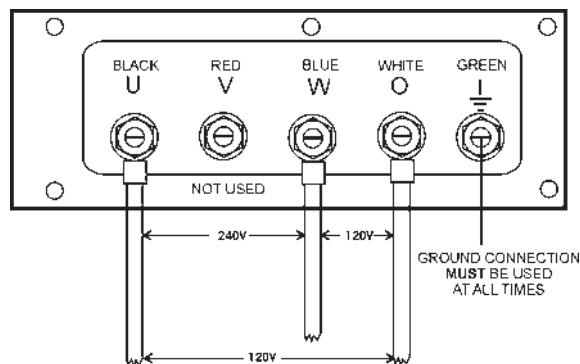

**Figure 26. UVWO Terminal Lugs
1Ø-240/120V Connections**

3. Turn the voltage regulator knob (Figure 20) clockwise to increase voltage output, turn counterclockwise to decrease voltage output. Use voltage regulator adjustment knob whenever fine tuning of the output voltage is required.

NOTICE

ALWAYS make sure that the connections to the UVWO terminals are **secure** and **tight**. The possibility of arcing exists, that could cause a fire.

CIRCUIT BREAKERS

To protect the generator from an overload, a 3-pole, 300 amp, main circuit breaker is provided to protect the **U, V, and W Output Terminals** from overload. In addition two single-pole, 20 amp **GFCI** circuit breakers are provided to protect the GFCI receptacles from overload. Three 50 amp **load** circuit breakers have also been provided to protect the auxiliary receptacles from overload. Make sure to switch **ALL** circuit breakers to the **OFF** position prior to starting the engine.

LUBRICATION OIL

Fill the engine crankcase with lubricating oil through the filler hole, but **DO NOT** overfill. Make sure the generator is level and verify that the oil level is maintained between the two notches (Figure 27) on the dipstick. See Table 11 for proper selection of engine oil.

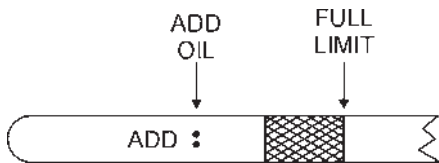

Figure 27. Engine Oil Dipstick

When checking the engine oil, be sure to check if the oil is clean. If the oil is not clean, drain the oil by removing the oil drain plug, and refill with the specified amount of oil as outlined in the **ISUZU Engine Owner's Manual**. Oil should be warm before draining.

Other types of motor oils may be substituted if they meet the following requirements:

- API Service Classification CC/SC
- API Service Classification CC/SD
- API Service Classification CC/SE
- API Service Classification CC/SF

Table 11. Recommended Motor Oil		OIL: SAE	
°F	°C	SAE	SAE
122	50	10W/40	10W/40
104	40	10W/40	30
86	30	10W/40	15W/30
68	20	10W/40	10W/30
50	10	10W/40	10W
32	0	10W/40	20W/40
-14	-10	ARCTIC OIL	5W/30
-4	-20	ARCTIC OIL	
-22	-30	ARCTIC OIL	
-40	-40	ARCTIC OIL	

FUEL CHECK

! DANGER



Fuel spillage on a **hot** engine can cause a **fire** or **explosion**. If fuel spillage occurs, wipe up the spilled fuel completely to prevent fire hazards. **NEVER** smoke around or near the generator.

Refilling the Fuel System

! CAUTION

ONLY properly trained personnel who have read and understand this section should refill the fuel tank system.

This generator has an internal fuel tank located inside the trailer frame and may also be equipped with an environmental fuel tank (Figure 28). **ALWAYS** fill the fuel tanks with clean fresh **#2 diesel fuel**. **DO NOT** fill the fuel tanks beyond their capacities.

Pay attention to the fuel tank capacity when replenishing fuel. The fuel tank cap must be closed tightly after filling. Handle fuel in a safety container. If the container does not have a spout, use a funnel. Wipe up any spilled fuel immediately.

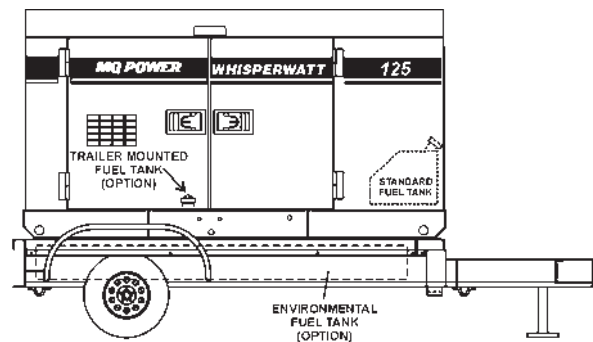



Figure 28. Internal Fuel Tank System

Refueling Procedure:

WARNING



Diesel fuel and its vapors are dangerous to your health and the surrounding environment. Avoid skin contact and/or inhaling fumes.

1. **Level Tanks** — Make sure fuel cells are level with the ground. Failure to do so will cause fuel to spill from the tank before reaching full capacity (Figure 29).

CAUTION

ALWAYS place trailer on firm level ground before refueling to prevent spilling and maximize the amount of fuel that can be pumped into the tank.

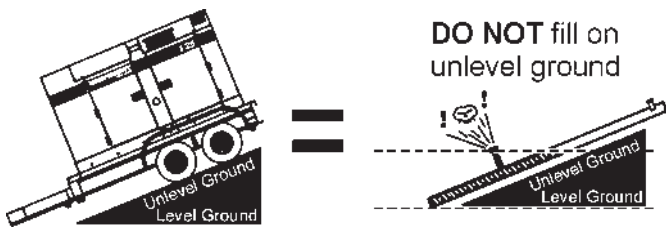

Figure 29. Only Fill on Level Ground

NOTICE

ONLY use #2 diesel fuel when refueling.

2. Open cabinet doors on the “right side” of the generator (from generator control panel position). Remove fuel cap and fill tank (Figure 30).

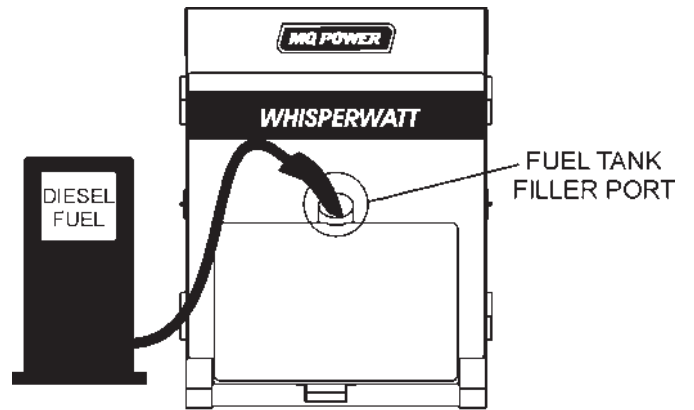

Figure 30. Fueling the Generator

3. **NEVER overfill fuel tank** — It is important to read the fuel gauge when filling trailer fuel tank. **DO NOT** wait for fuel to rise in filler neck (Figure 31).

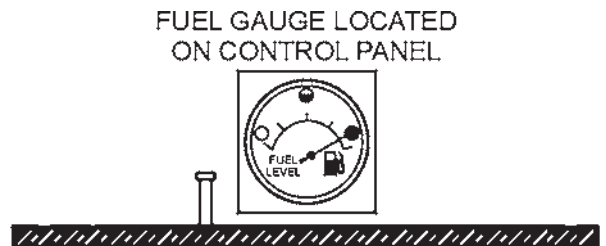

Figure 31. Full Fuel Tank

CAUTION

DO NOT OVERFILL fuel system. Leave room for fuel expansion. Fuel expands when heated (Figure 32).



Figure 32. Fuel Expansion

COOLANT (ANTIFREEZE/SUMMER COOLANT/WATER)

ISUZU recommends ISUZU antifreeze/summer coolant for use in their engines, which can be purchased in concentrate (and mixed with 50% demineralized water) or pre-diluted. See the **ISUZU Engine Owner's Manual** for further details.

WARNING



If adding coolant/antifreeze mix to the radiator, **DO NOT** remove the radiator cap until the unit has completely cooled. The possibility of **hot!** coolant exists which can cause severe burns.

Day-to-day addition of coolant is done from the recovery tank. When adding coolant to the radiator, **DO NOT** remove the radiator cap until the unit has completely cooled. See Table 12 for engine, radiator, and recovery tank coolant capacities. Make sure the coolant level in the recovery tank is always between the “H” and the “L” markings.

Table 12. Coolant Capacity	
Engine and Radiator	5.3 gal (20.2 liters)
Reserve Tank	2 quarts (1.9 liters)

Operation in Freezing Weather

When operating in freezing weather, be certain the proper amount of antifreeze (Table 13) has been added.

Table 13. Anti-Freeze Operating Temperatures		
Vol % Anti-Freeze	Freezing Point	
	°C	°F
50	-37	-34

NOTICE

When the antifreeze is mixed with water, the antifreeze mixing ratio **must be** less than 50%.

CLEANING THE RADIATOR

The engine may overheat if the radiator fins become overloaded with dust or debris. Periodically clean the radiator fins with compressed air. Cleaning inside the machine is dangerous, so clean only with the engine turned off and the **negative** battery terminal disconnected.

AIR CLEANER

Periodic cleaning/replacement is necessary. Inspect it in accordance with the **ISUZU Engine Owner's Manual**.

FAN BELT TENSION

A slack fan belt may contribute to overheating, or to insufficient charging of the battery. Inspect the fan belt for damage and wear and adjust it in accordance with the **ISUZU Engine Owner's Manual**.

The fan belt tension is proper if the fan belt bends 10 to 15 mm (Figure 33) when depressed with the thumb as shown below.

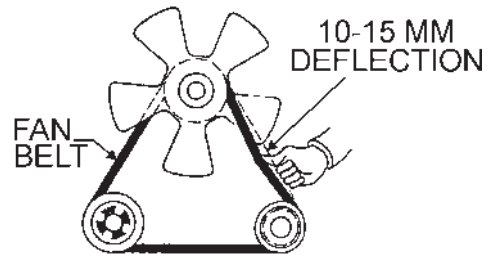



Figure 33. Fan Belt Tension

CAUTION



NEVER place hands near the belts or fan while the generator set is running.

BATTERY

This unit is of negative ground **DO NOT** connect in reverse. Always maintain battery fluid level between the specified marks. Battery life will be shortened, if the fluid level are not properly maintained. Add only distilled water when replenishment is necessary.

DO NOT over fill. Check to see whether the battery cables are loose. Poor contact may result in poor starting or malfunctions. **Always** keep the terminals firmly tightened. Coating the terminals with an approved battery terminal treatment compound. Replace battery with only recommended type battery. The battery type used in this generator is BCI Group 27.

The battery is sufficiently charged if the specific gravity of the battery fluid is 1.28 (at 68° F). If the specific gravity should fall to 1.245 or lower, it indicates that the battery is dead and needs to be recharged or replaced.

Before charging the battery with an external electric source, be sure to disconnect the battery cables.

Battery Cable Installation

ALWAYS be sure the battery cables (Figure 34) are properly connected to the battery terminals as shown below. The **red cable** is connected to the positive terminal of the battery, and the **black cable** is connected to the negative terminal of the battery.

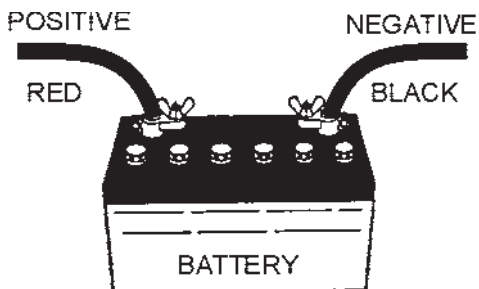
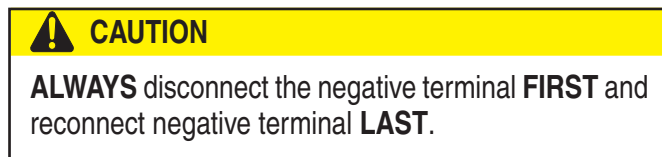

Figure 34. Battery Connections

When connecting battery do the following:

1. **NEVER** connect the battery cables to the battery terminals when the **MPEC Control Switch** is in either the **MANUAL** position. **ALWAYS** make sure that the **MPEC Control Switch** is in the **OFF/RESET** position when connecting the battery.
2. Place a small amount of battery terminal treatment compound around both battery terminals. This will ensure a good connection and will help prevent corrosion around the battery terminals.

NOTICE

If the battery cable is connected incorrectly, electrical damage to the generator will occur. Pay close attention to the polarity of the battery when connecting the battery.

CAUTION

Inadequate battery connections may cause poor starting of the generator, and create other malfunctions.

ALTERNATOR

The polarity of the alternator is negative grounding type. When an inverted circuit connection takes place, the circuit will be in short circuit instantaneously resulting the alternator failure.

DO NOT put water directly on the alternator. Entry of water into the alternator can cause corrosion and damage the alternator.

WIRING

Inspect the entire generator for bad or worn electrical wiring or connections. If any wiring or connections are exposed (insulation missing) replace wiring immediately.

PIPING AND HOSE CONNECTION

Inspect all piping, oil hose, and fuel hose connections for wear and tightness. Tighten all hose clamps and check hoses for leaks.

If any hose (**fuel or oil**) lines are defective replace them immediately.

GENERATOR START-UP PROCEDURE (MANUAL)

BEFORE STARTING

CAUTION

The engine's exhaust contains harmful emissions. **ALWAYS** have adequate ventilation when operating. Direct exhaust away from nearby personnel.

WARNING

NEVER manually start the engine with the **main, GFCI or auxiliary** circuit breakers in the **ON** (closed) position.

1. Place the **main, G.F.C.I., and aux.** circuit breakers (Figure 35) in the **OFF** position prior to starting the engine.

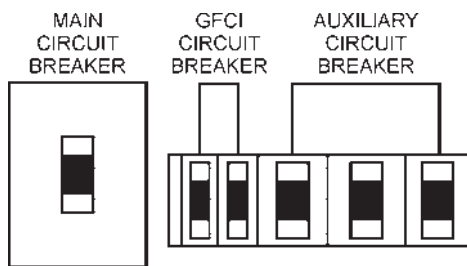

Figure 35. Main, Aux. and GFCI Circuit Breakers (OFF)

2. Make sure the **voltage change-over board** has been configured for the desired output voltage.
3. Connect the load to the **receptacles** or the **output terminal lugs** as shown in Figure 10. These load connection points can be found on the output terminal panel and the output terminal panel's hard wire hookup panel.
4. Tighten terminal nuts securely to prevent load wires from slipping out.
5. Close all engine enclosure doors (Figure 36).

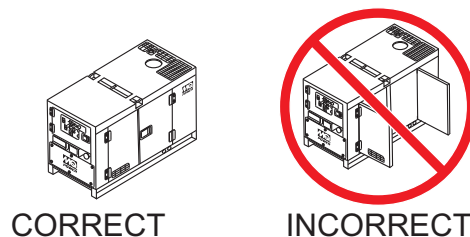

Figure 36. Engine Enclosure Doors

STARTING (MANUAL)

1. Place the engine speed switch (Figure 37) in the **LOW** (down) position.



Figure 37. Engine Speed Switch (Low)

2. Place the **MPEC control switch** in the **MANUAL** position to start the engine (Figure 38).



Figure 38. MPEC Control Switch (Manual Position)

3. Depending on the temperature of the coolant (cold weather conditions), the pre-heat lamp (Figure 39) will light (ON) and remain on until the pre-heating cycle has been completed. After completion of the pre-heating cycle, the light will go OFF and the engine will start up automatically.

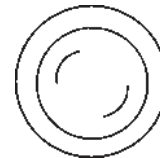

Figure 39. Pre-Heat Lamp

4. Once the engine starts, let the engine run for 1-2 minutes. Listen for any abnormal noises. If any abnormalities exist, shut down the engine and correct the problem. If the engine is running smoothly, place the engine speed switch (Figure 40) in the **HIGH** (up) position.



Figure 40. Engine Speed Switch (High)

5. Verify that the **engine running status LED** on the MPEC unit (Figure 41) is **ON** (lit) after the engine has been started.



Figure 41. Engine Running LED (ON)

GENERATOR START-UP PROCEDURE (MANUAL)

6. The generator's frequency meter (Figure 42) should be displaying the 60 cycle output frequency in **HERTZ**.

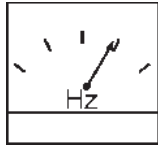

Figure 42. Frequency Meter

7. The generator's AC-voltmeter (Figure 43) will display the generator's output in **VOLTS**. If the voltage is not within the specified tolerance, use the voltage adjustment control knob (Figure 44) to increase or decrease the desired voltage.

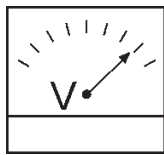

Figure 43. Voltmeter



Figure 44. Voltage Adjust Control Knob

8. The ammeter (Figure 45) will indicate **zero amps** with no load applied. When a load is applied, the ammeter will indicate the amount of current that the load is drawing from the generator.

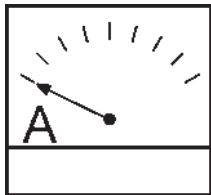

Figure 45. Ammeter (No Load)

9. The engine oil pressure gauge (Figure 46) will indicate the oil pressure of the engine. Under normal operating conditions the oil pressure is approximately 42 to 71 psi. (290~490 kPa).

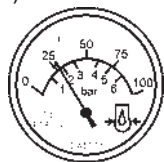

Figure 46. Oil Pressure Gauge

10. The **coolant temperature gauge** (Figure 47) will indicate the coolant temperature. Under normal operating conditions the coolant temperature should be between 167°~203°F (75°~95°C) (**Green Zone**).

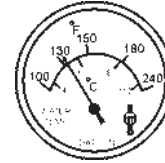

Figure 47. Coolant Temperature Gauge

11. The **tachometer gauge** (Figure 48) will indicate the speed of the engine when the generator is operating. Under normal operating conditions this speed is approximately 1800 RPM's.

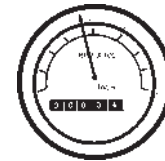

Figure 48. Engine Tachometer Gauge

12. Place the **main, GFCI, and aux.** circuit breakers in the **ON** position (Figure 49).

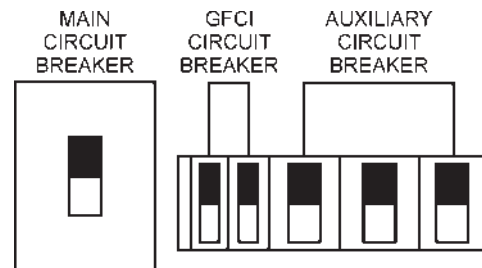

Figure 49. Main, Aux. and GFCI Circuit Breakers (ON)

13. Observe the generator's ammeter (Figure 50) and verify it reads the anticipated amount of current with respect to the load. The ammeter will only display a current reading if a load is in use.

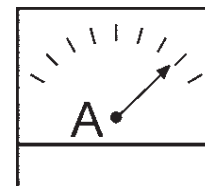

Figure 50. Ammeter (Load)

14. The generator will run until manually stopped or an abnormal condition occurs.

GENERATOR START-UP PROCEDURE (AUTO MODE)

STARTING (AUTO MODE)

DANGER



Before connecting this generator to any building's electrical system, a **licensed electrician** must install an **isolation (transfer) switch**. Serious damage to the building's electrical system may occur without this transfer switch.

CAUTION

When connecting the generator to a isolation (transfer) switch, **ALWAYS** have power applied to the generator's internal battery charger. This will ensure that the engine will not fail due to a dead battery.

NOTICE

When the generator is set in the **AUTO** mode, the generator will **automatically start** in the event of commercial power falling below a prescribed level by means of a contact closure that is generated automatically by a transfer switch.

WARNING

When running the generator in the **AUTO** mode, remember the generator can start up at any time without warning. **NEVER** attempt to perform any maintenance when the generator is in the auto mode.

CAUTION

The engine speed switch **must** be set to the "High" position when running in the **auto-start** mode. Failing to set the switch in the proper position can result in damage to your generator when it turns on.

NOTICE

When the MPEC control switch is placed in the **AUTO** position, the engine glow plugs will be warmed and the engine will start automatically.

When starting generator in **AUTO** mode use the "Manual Start-up" procedure except where noted (see below).

1. Perform steps 1 through 5 in the Before Starting section as outlined in the Manual Starting Procedure.
2. Place the **engine speed switch** (Figure 51) in the **HIGH** position



Figure 51. Engine Speed Switch (High)

3. Place the **MPEC Control Switch** (Figure 52) in the **AUTO** position.



Figure 52. MPEC Control Switch (AUTO)

4. Continue operating the generator as outlined in the Manual Start-up procedure (start at step 5).

GENERATOR SHUT-DOWN PROCEDURES

WARNING

NEVER stop the engine suddenly except in an emergency.

NORMAL SHUTDOWN PROCEDURE

To shutdown the generator, use the following procedure:

1. Place both the **MAIN, GFCI and LOAD** circuit breakers as shown in Figure 35 to the **OFF** position.
2. Place the engine speed switch (Figure 53) in the “LOW” (down) position.



Figure 53. Engine Speed Switch (Low)

3. Let the engine cool by running it at low speed for 3-5 minutes with no load applied.
4. Place the **MPEC Control Switch** (Figure 54) to the **OFF/RESET** position.



Figure 54. MPEC Control Switch (Off/Reset)

5. Verify that **all** the status LEDs on the MPEC display are **OFF** (not lit).
6. Remove all loads from the generator.
7. Inspect entire generator for any damage or loosening of components that may have occurred during operation.

EMERGENCY SHUTDOWN PROCEDURE

1. Place the ECU Control Switch switch (Figure 54) to the OFF/Reset position.
2. To shut-down the engine in the event of an emergency, switch the MAIN, GFCI and LOAD (Figure 38) circuit breakers to OFF position.

Table 14. Inspection/Maintenance		10 Hrs DAILY	250 Hrs	500 Hrs	1000 Hrs
Engine	Check Engine Fluid Levels	X			
	Check Air Cleaner	X			
	Check Battery Acid Level	X			
	Check Fan Belt Condition	X			
	Check for Leaks	X			
	Check for Loosening of Parts	X			
	Replace Engine Oil and Filter * 1		X		
	Clean Air Filter		X		
	Check Fuel Filter/Water Separator Bowl	X			
	Clean Unit, Inside and Outside		X		
	Change Fuel Filter			X	
	Clean Radiator and Check Coolant Protection Level*2			X	
	Replace Air Filter Element * 3			X	
	Check all Hoses and Clamps * 4				X
	Clean Inside of Fuel Tank				X
Generator	Measure Insulation Resistance Over 3M ohms		X		
	Check Rotor Rear Support Bearing			X	

*1 Replace engine oil and filter at 100 hours, first time only.

*2 Add "Supplemental Coolant Additives (SCA'S)" to recharge the engine coolant.

*3 Replace primary air filter element when restriction indicator shows a vacuum of 625 mm (25 in. H2O).

*4 If blowby hose needs to be replaced, ensure that the slope of the blowby hose is at least a 1/2 inch per foot, with no sags or dips that could collect moisture and/or oil.

GENERAL INSPECTION

Prior to each use, the generator should be cleaned and inspected for deficiencies. Check for loose, missing or damaged nuts, bolts or other fasteners. Also check for fuel, oil, and coolant leaks. Use Table 14 as a general maintenance guideline **Engine Side** (Refer to the Engine Instruction Manual)

AIR CLEANER

Every 250 hours: Remove air cleaner element (Figure 56) and clean the heavy duty paper element with light spray of compressed air. Replace the air cleaner as needed.

Air Cleaner with Dust Indicator

This indicator (Figure 55) is attached to the air cleaner. When the air cleaner element is clogged, air intake restriction becomes greater and the dust indicator signal shows **RED** meaning the element needs changing or service. After changing the air element, press the dust indicator button to reset the indicator.

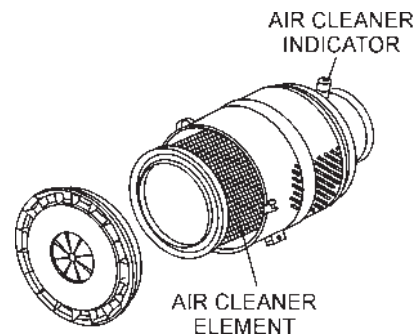

Figure 55. Air Cleaner/Indicator

NOTICE

The air filter should not be changed until the indicator reads "**RED**". Dispose of old air filter. It may not be cleaned or reused.

If the engine is operating in very **dusty** or **dry grass** conditions, a clogged air cleaner will result. This can lead to a loss of power, excessive carbon buildup in the combustion chamber and high fuel consumption. Change air cleaner more **frequently** if these conditions exist.

FUEL ADDITION

Add diesel fuel (the grade may vary according to season and locations).

Removing Water from the Fuel Tank

After prolonged use, water and other impurities accumulate in the bottom of the tank. Occasionally inspect the fuel tank for water contamination and drain the contents if required.

During cold weather, the more empty volume inside the tank, the easier it is for water to condense. This can be reduced by keeping the tank full with diesel fuel.

Cleaning Inside the Fuel Tank

If necessary, drain the fuel inside the fuel tank completely. Using a spray washer (Figure 56) wash out any deposits or debris that have accumulated inside the fuel tank.

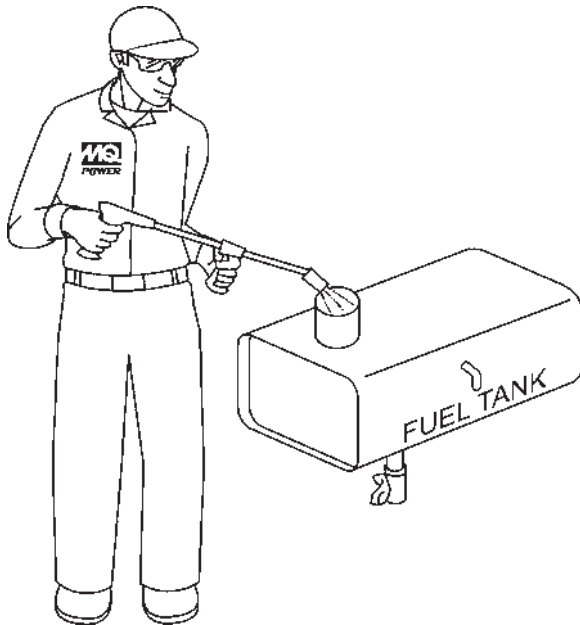

Figure 56. Fuel Tank Cleaning

FUEL TANK INSPECTION

In addition to cleaning the fuel tank, the following components should be inspected for wear:

- **Rubber Suspension** — look for signs of wear or deformity due to contact with oil. Replace the rubber suspension if necessary.
- **Fuel Hoses** — inspect nylon and rubber hoses for signs of wear, deterioration and hardening.
- **Fuel Tank Lining** — inspect the fuel tank lining for signs of excessive amounts of oil or other foreign matter.

Replacing Fuel Filter

- Replace the fuel filter cartridge with new one every 500 hours or so.
- Loosen the drain plug at the lower top of the fuel filter. Drain the fuel in the fuel body together with the mixed water. **DO NOT** spill the fuel during disassembly.
- Vent any air

AIR REMOVAL

If air enters the fuel injection system of a diesel engine, starting becomes impossible. After running out of fuel, or after disassembling the fuel system, bleed the system according to the following procedure. See the **ISUZU Engine Manual** for details.

To restart after running out of fuel, turn the switch to the “ON” position for 15-30 seconds. Try again, if needed.

CHECK OIL LEVEL

Check the crankcase oil level prior to each use, or when the fuel tank is filled. Insufficient oil may cause severe damage to the engine. Make sure the generator is level. The oil level must be between the two notches on the dipstick as shown in Figure 27.

Replacing Oil Filter

- Remove the old oil filter.
- Apply a film of oil to the gasket on the new oil filter.
- Install the new oil filter.
- After the oil cartridge has been replaced, the engine oil will drop slightly. Run the engine for a while and check for leaks before adding more oil if needed. Clean excessive oil from engine.

FLUSHING OUT RADIATOR AND REPLACING COOLANT

- Open both cocks located at the crankcase side and at the lower part of the radiator and drain coolant. Open the radiator cap while draining. Remove the overflow tank and drain.
- Check hoses for softening and kinks. Check clamps for signs of leakage.
- Tighten both cocks and replace the overflow tank.
- Replace with coolant as recommended by the engine manufacturer.
- Close radiator cap tightly.
- Flush the radiator by running clean tap water through radiator until signs of rust and dirt are removed. **DO NOT** clean radiator core with any objects, such as a screwdriver.

WARNING



Allow engine to **cool** when flushing out radiator. Flushing the radiator while hot could cause serious burns from water or steam.

RADIATOR CLEANING

The radiator (Figure 57) should be sprayed (cleaned) with a high pressure washer when excessive amounts of dirt and debris have accumulated on the cooling fins or tube. When using a high pressure washer, stand at least 5 feet (1.5 meters) away from the radiator to prevent damage to the fins and tube.

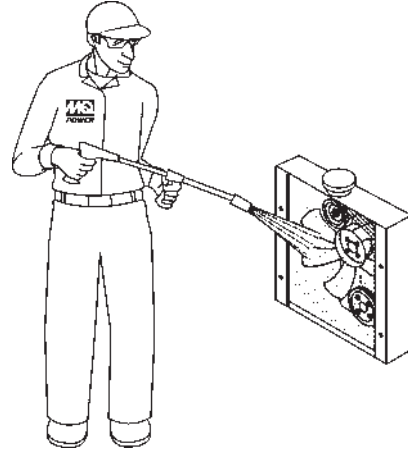

Figure 57. Radiator Cleaning

GENERATOR STORAGE

For long term storage of the generator the following is recommended:

- Drain the fuel tank completely. Treat with a fuel stabilizer if necessary.
- Completely drain the oil from the crankcase and refill if necessary with fresh oil.
- Clean the entire generator, internal and external.
- Cover the generating set and store in a clean, dry place.
- Disconnect the battery.
- Make sure engine coolant is at proper level.
- If generator is mounted on a trailer, jack trailer up and place on blocks so tires do not touch the ground or block and completely remove the tires.

JACKET WATER HEATER AND INTERNAL BATTERY CHARGER 120 VAC INPUT RECEPTACLES (OPTIONAL)

This generator can be optionally equipped with two 120 VAC, 20 amp input receptacles located on the output terminal panel.

The purpose of these receptacles is to provide power via commercial power to the **jacket water heater** and **internal battery charger**.

These receptacles will **ONLY** function when commercial power has been supplied to them (Figure 58). To apply commercial power to these receptacles, a power cord of adequate size will be required (See Table 6).

When using the generator in **hot** climates there is no reason to apply power to jacket water heater. However, if the generator will be used in **cold** climates it is always a good idea to apply power to the jacket water heater at all times. To apply power to the jacket water heater simply apply power to the jacket water heater receptacle via commercial power using an power cord of adequate size.

If the generator will be used daily, the battery should normally not require charging. If the generator will be idle (not used) for long periods of time, apply power to the battery charger receptacle via commercial power using a power cord of adequate size.

NOTICE

To ensure adequate starting capability, always have power applied to the generator's internal battery charger.

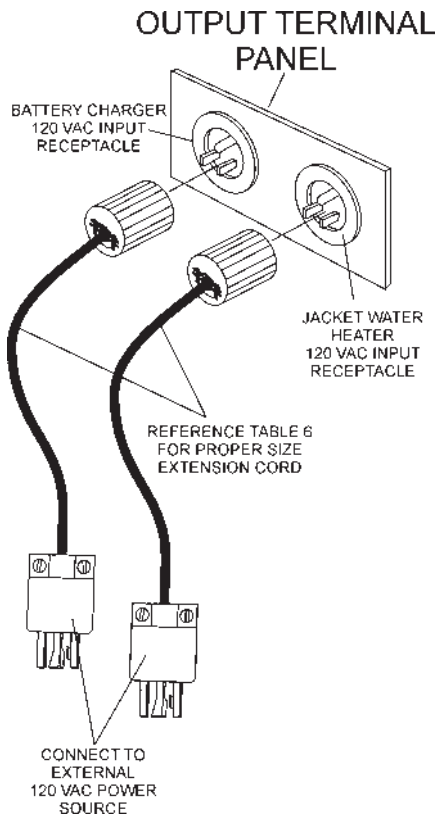

Figure 58. Battery Charger and Jacket Water Heater Power Connections

TRAILER MAINTENANCE

TRAILER MAINTENANCE

This section is intended to provide the user with generic trailer service and maintenance information. The service and maintenance guidelines referenced in this section refer to a wide range of trailers.

Remember periodic inspection of the trailer will ensure safe towing of the generator and will prevent personal injury and damage to the equipment.

The definitions below describe some of the major components of a typical trailer that would be used with generator.

1. **Fuel Cell** — Provides an adequate amount of fuel for the equipment in use. Fuel cells must be empty when transporting equipment.
2. **Braking System** — System employed in stopping the trailer. Typical braking systems are electric, surge, hydraulic, hydraulic-surge and air.
3. **GVWR** — Gross Vehicle Weight Rating (GVWR) is the maximum number of pounds the trailer can carry, including the fuel cell (empty).
4. **Frame Length** — Measurement is from the ball hitch to the rear bumper (reflector).
5. **Frame Width** — Measurement is from fender to fender
6. **Jack Stand** — Trailer support device with maximum pound requirement from the tongue of the trailer.
7. **Coupler** — Type of hitch used on the trailer for towing.
8. **Tire Size** — Indicates the diameter of the tire in inches (10,12,14, etc.), and the width in millimeters (175,185,205, etc.). The tire diameter must match the diameter of the tire rim.
9. **Tire Ply** — The tire ply (layers) number is rated in letters; 2-ply,4-ply,6-ply, etc.
10. **Wheel Hub** — The wheel hub is connected to the trailer's axle.
11. **Tire Rim** — Tires mounted on a tire rim. The tire rim must match the size of the tire.
12. **Lug Nuts** — Used to secure the wheel to the wheel hub. Always use a torque wrench to tighten down the lug nuts. See Table 18 and Figure 62 for lug nut tightening and sequence.
13. **Axle** — Indicates the maximum weight the axle can support in pounds, and the diameter of the axle expressed in inches. Please note that some trailers have a double axle. This will be shown as 2-6000 lbs., meaning two axles with a total weight capacity of 6000 pounds.
14. **Suspension** — Protects the trailer chassis from shocks transmitted through the wheels. Types of suspension used are leaf, Q-flex, and air ride.
15. **Electrical** — Electrical connectors (looms) are provided with the trailer so the brake lights and turn signals can be connected to the towing vehicle.
16. **Application** — Indicates which units can be employed on a particular trailer.

BRAKES

Trailer brakes should be inspected the **first 200 miles** of operation. This will allow the brake shoes and drums to seat properly. After the first 200 mile interval, inspect the brakes **every 3,000 miles**. If driving over rough terrain, inspect the brakes more frequently.

Figure 59 displays the major hydraulic surge brake components that will require inspection and maintenance. Please inspect these components as required using steps 1 through 8 and Table 15 as listed below:

Brake Adjustment

1. Place the trailer on jack stands. Make sure the jack stands are placed on secure level ground.
2. Check the wheel and drum for free rotation.
3. Remove the adjusting hole cover from the adjusting slot at the bottom brake backing plate.
4. With a screwdriver or standard adjusting tool, rotate the star wheel of the adjuster assembly to expand the brake shoes.
5. Adjust the brake shoes outward until the pressure of the lining against the wheel drum makes the wheel difficult to turn.
6. Adjust, rotate the star wheel in the opposite direction until the wheel rotates freely with slight lining drag.
7. Replace the adjusting hole cover and lower the trailer to the ground.
8. Repeat steps 1 through 7 on the remaining brakes.

Hydraulic Surge Brakes

Hydraulic surge brakes (Figure 59) should not require any special attention with the exception of routine maintenance such as shoe and lining replacement. Brake lines should be periodically checked for cracks, kinks, or blockage.

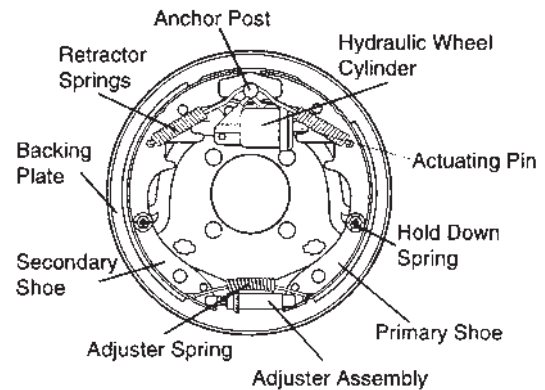

Figure 59. Hydraulic Brake Components

Actuator

Hydraulic surge braking requires the installation of an actuator at the tongue of the trailer. Remember the **surge or push** of the trailer toward the tow vehicle automatically synchronizes the trailer brakes with the tow vehicle brakes. As the trailer pushes against the tow vehicle the actuator telescopes together and applies force to the master cylinder, supplying hydraulic pressure to the trailer brakes.

Periodically check and test the surge “actuator” to make sure that it is functioning correctly. Never use an undersize actuator.

Table 15. Hydraulic Brake Troubleshooting

Symptom	Possible Cause	Solution
No Brakes	Brake line broken or kinked?	Repair or replace.
Weak Brakes or Brakes Pull to One Side	Brake lining glazed?	Reburnish or replace.
	Trailer overloaded?	Correct weight.
	Brake drums scored or grooved?	Machine or replace.
	Tire pressure correct?	Inflate all tires equally.
Locking Brakes	Tires unmatched on the same axle?	Match tires.
	Brake components loose, bent or broken?	Replace components.
Noisy Brakes	Brake drums out-of-round?	Replace.
	System lubricated?	Lubricate.
Dragging Brakes	Brake components correct?	Replace and correct.
	Brake lining thickness incorrect or not adjusted correctly?	Install new shoes and linings.
	Enough brake fluid or correct fluid?	Replace rubber parts fill with dot 4 fluid.

TRAILER MAINTENANCE

TIRES/WHEELS/LUG NUTS

Tires and wheels are a very important and critical components of the trailer. When specifying or replacing the trailer wheels it is important the wheels, tires, and axle are properly matched.

CAUTION



ALWAYS wear safety glasses when removing or installing force fitted parts. Failure to comply may result in serious injury.

CAUTION



DO NOT attempt to repair or modify a wheel. **DO NOT** install in inner tube to correct a leak through the rim. If the rim is cracked, the air pressure in the inner tube may cause pieces of the rim to explode (break off) with great force and cause serious eye or bodily injury.

Tire Wear/Inflation

Tire inflation pressure is the most important factor in tire life. Pressure should be checked cold before operation **DO NOT** bleed air from tires when they are **hot!**. Check inflation pressure weekly during use to insure the maximum tire life and tread wear.

Table 16 (Tire Wear Troubleshooting) will help pinpoint the causes and solutions of tire wear problems.

Table 16. Tire Wear Troubleshooting			
Wear Pattern	Cause	Solution	
	Center Wear	Over inflation.	Adjust pressure to particular load per tire manufacturer.
	Edge Wear	Under inflation.	Adjust pressure to particular load per tire manufacturer.
	Side Wear	Loss of camber or overloading.	Make sure load does not exceed axle rating. Align wheels.
	Toe Wear	Incorrect toe-in.	Align wheels.
	Cupping	Out-of-balance.	Check bearing adjustment and balance tires.
	Flat Spots	Wheel lockup and tire skidding.	Avoid sudden stops when possible and adjust brakes.

Suspension

The **leaf suspension** springs and associated components (Figure 60) should be visually inspected every 6,000 miles for signs of excessive wear, elongation of bolt holes, and loosening of fasteners. Replace all damaged parts (suspension) immediately. Torqued suspension components as detailed in Table 17.

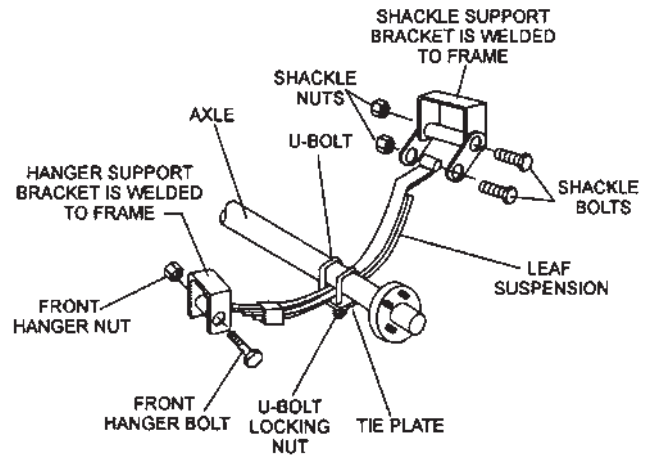

Figure 60. Major Suspension Components

Table 17. Suspension Torque Requirements	
Item	Torque (Ft.-Lbs.)
3/8" U-Bolt	Min-30 Max-35
7/16" U-Bolt	Min-45 Max-60
1/2" U-Bolt	Min-45 Max-60
Shackle Bolt Spring Eye Bolt	Snug fit only. Parts must rotate freely. Locking nuts or cotter pins are provided to retain nut-bolt assembly.
Shoulder Type Shackle Bolt	Min-30 Max-50

TRAILER MAINTENANCE

Lug Nut Torque Requirements

It is extremely important to apply and maintain proper wheel mounting torque on the trailer. Be sure to use only the fasteners matched to the cone angle of the wheel. Proper procedure for attachment of the wheels is as follows:

1. Start all wheel lug nuts by hand.
2. Torque all lug nuts in sequence (see Figure 61). **DO NOT** torque the wheel lug nuts all the way down.

Wheel Size	First Pass FT-LBS	Second Pass FT-LBS	Third Pass FT-LBS
12"	20-25	35-40	50-65
13"	20-25	35-40	50-65
14"	20-25	50-60	90-120
15"	20-25	50-60	90-120
16"	20-25	50-60	90-120

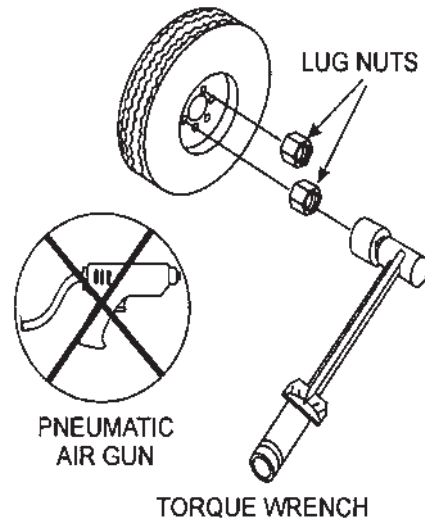
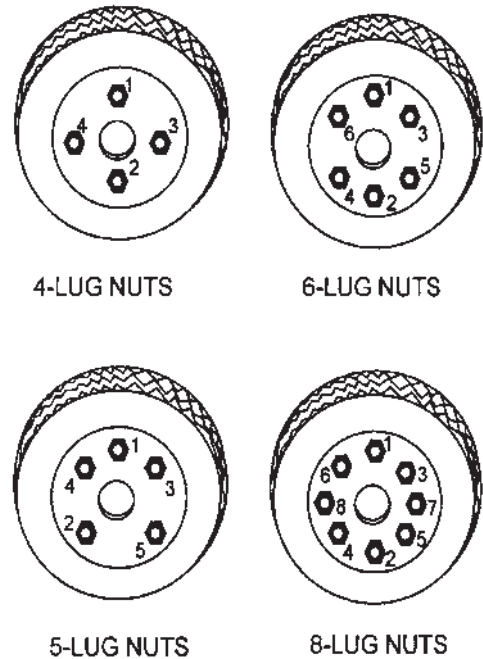

Figure 61. Wheel Lug Nuts Tightening Sequence

NOTICE

NEVER use an pneumatic air gun to tighten wheel lug nuts.

TRAILER WIRING DIAGRAM

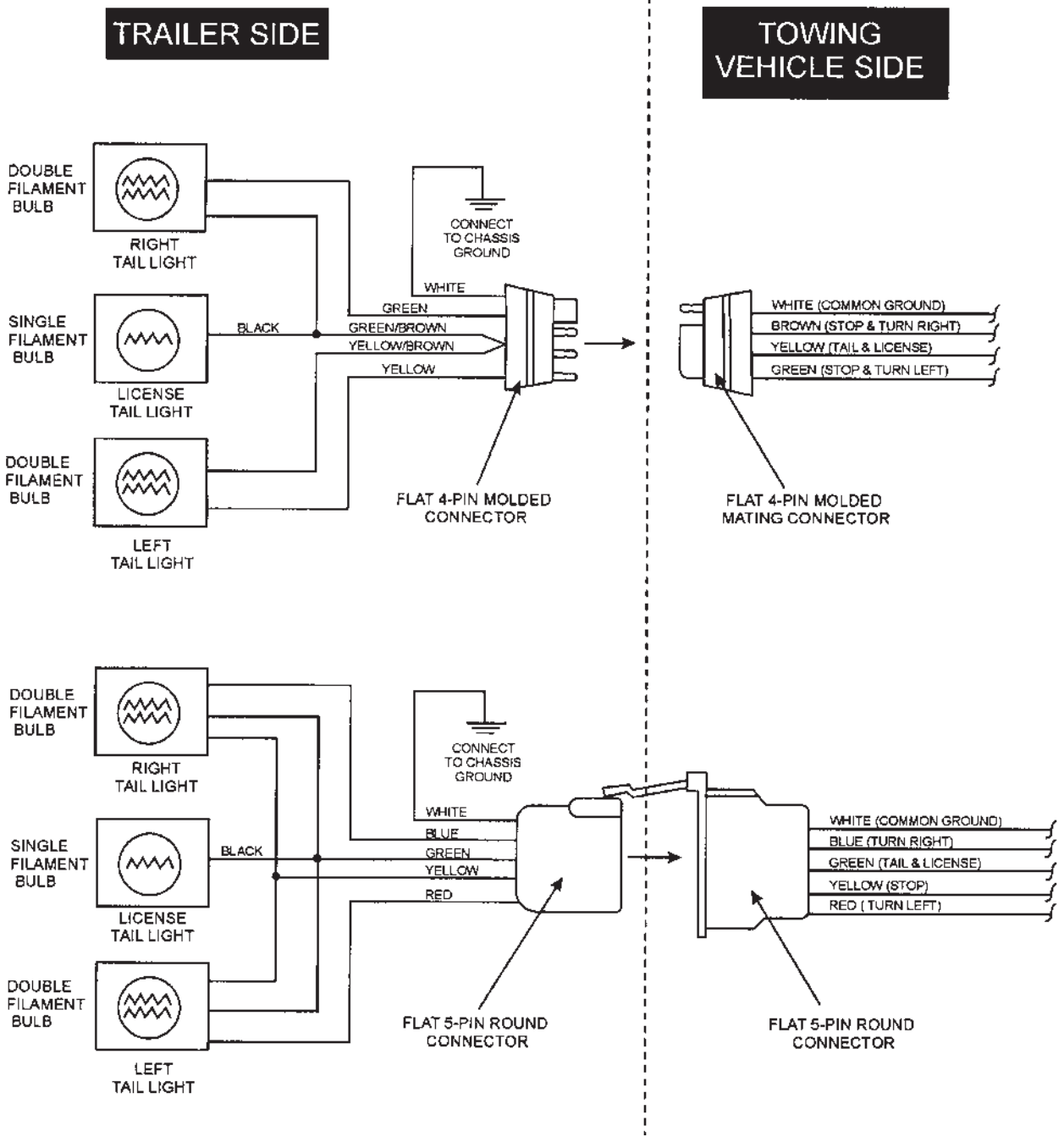
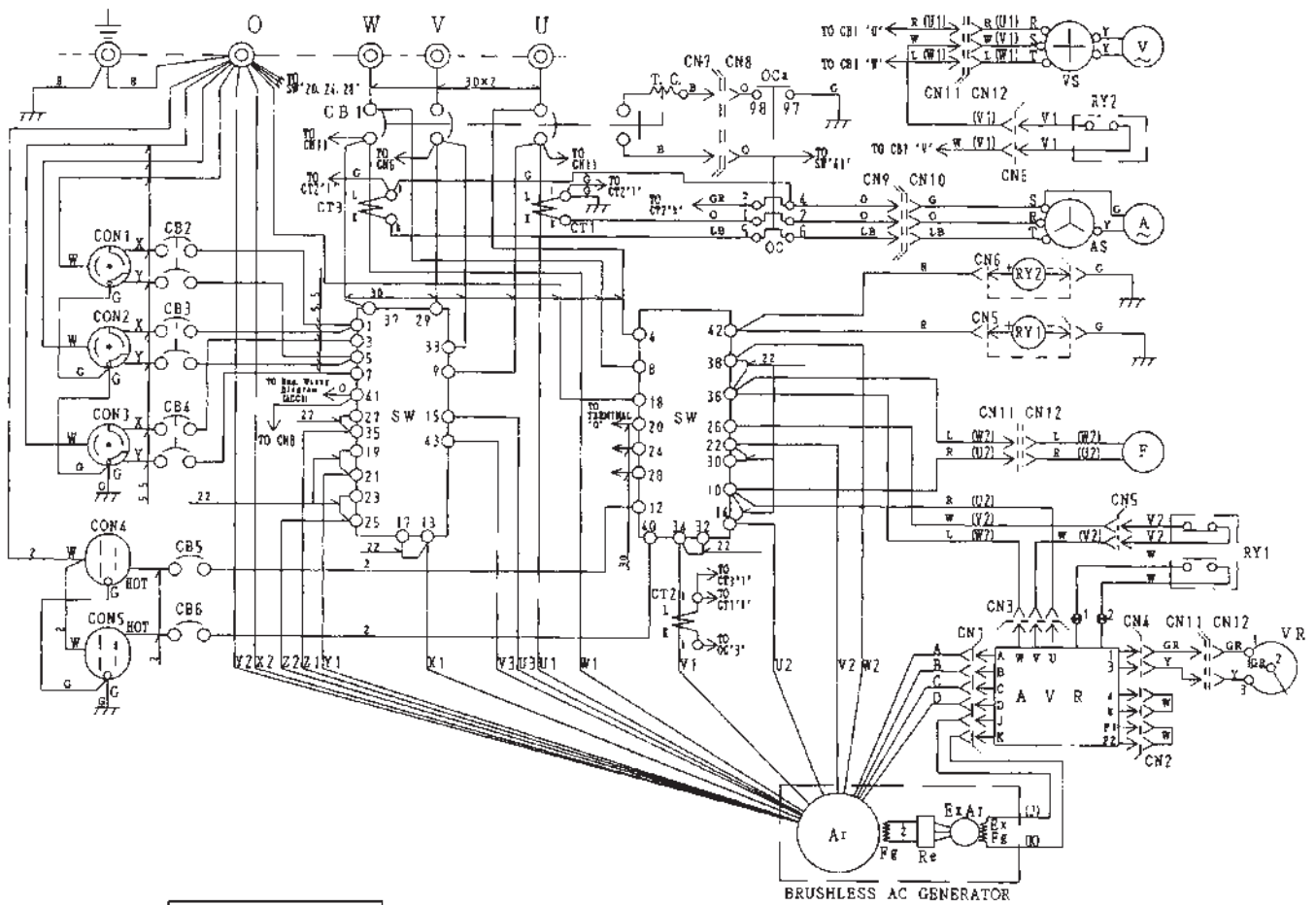

Figure 62. Trailer/Towing Vehicle Wiring Diagram

GENERATOR WIRING DIAGRAM



COLOR CODE	
WIRE COLOR	WIRE COLOR
B BLACK	R RED
L BLUE	W WHITE
BR BROWN	Y YELLOW
G GREEN	LB LIGHT BLUE
GR GRAY	LG LIGHT GREEN
V VIOLET	O ORANGE
P PINK	

<table border="0"> <tr><td>1 2 3</td><td>A J C</td></tr> <tr><td>B K D</td><td></td></tr> </table>	1 2 3	A J C	B K D		<table border="0"> <tr><td>1 2 3 4</td><td>V1 V1 +</td></tr> <tr><td>2 1</td><td></td></tr> </table>	1 2 3 4	V1 V1 +	2 1		<table border="0"> <tr><td>3 2 1</td><td>W1 V1 U1</td></tr> <tr><td>1 U2</td><td></td></tr> <tr><td>3 V2</td><td></td></tr> </table>	3 2 1	W1 V1 U1	1 U2		3 V2	
1 2 3	A J C															
B K D																
1 2 3 4	V1 V1 +															
2 1																
3 2 1	W1 V1 U1															
1 U2																
3 V2																
<table border="0"> <tr><td>1 2 3 4</td><td>k P1 P2</td></tr> </table>	1 2 3 4	k P1 P2	<table border="0"> <tr><td>1 2</td><td>B B</td></tr> </table>	1 2	B B											
1 2 3 4	k P1 P2															
1 2	B B															
<table border="0"> <tr><td>1 2 3</td><td>U V W</td></tr> </table>	1 2 3	U V W	<table border="0"> <tr><td>1 2</td><td>41 38</td></tr> </table>	1 2	41 38	<table border="0"> <tr><td>1 2 3</td><td>U1 V1 W1</td></tr> <tr><td>U2 1</td><td></td></tr> <tr><td>V2 3</td><td></td></tr> </table>	1 2 3	U1 V1 W1	U2 1		V2 3					
1 2 3	U V W															
1 2	41 38															
1 2 3	U1 V1 W1															
U2 1																
V2 3																
<table border="0"> <tr><td>1 3</td><td>1 3</td></tr> </table>	1 3	1 3	<table border="0"> <tr><td>3 2 1</td><td>6 4 2</td></tr> </table>	3 2 1	6 4 2											
1 3	1 3															
3 2 1	6 4 2															
<table border="0"> <tr><td>1 2 3 4</td><td>V2 V2 -</td></tr> </table>	1 2 3 4	V2 V2 -	<table border="0"> <tr><td>1 2 3</td><td>R S T</td></tr> </table>	1 2 3	R S T											
1 2 3 4	V2 V2 -															
1 2 3	R S T															

CONNECTOR ARRANGEMENT (WIRING VIEW)

SYMBOL	DESIGNATION
Ar	MAIN GENERATOR ARMATURE WINDING
Fg	MAIN GENERATOR FIELD WINDING
ExAr	EXCITER ARMATURE WINDING
ExFg	EXCITER FIELD WINDING
Re	RECTIFIER
AVR	AUTOMATIC VOLTAGE REGULATOR
VR	VOLTAGE REGULATOR (RHEOSTAT)
CT 1,2,3	CURRENT TRANSFORMER
AS	CHANGE-OVER SWITCH, AMMETER
A~	AC AMMETER
VS	CHANGE-OVER SWITCH, VOLTMETER
V	AC VOLTMETER
F	FREQUENCY METER
OC	OVER CURRENT RELAY
CB 1,2,3,4,5,6	CIRCUIT BREAKER
CON 1,2,3,4,5	RECEPTACLE
SW	SEPARATOR SWITCH
RY 1, 2	RELAY

Figure 63. Generator Wiring Diagram

ENGINE WIRING DIAGRAM

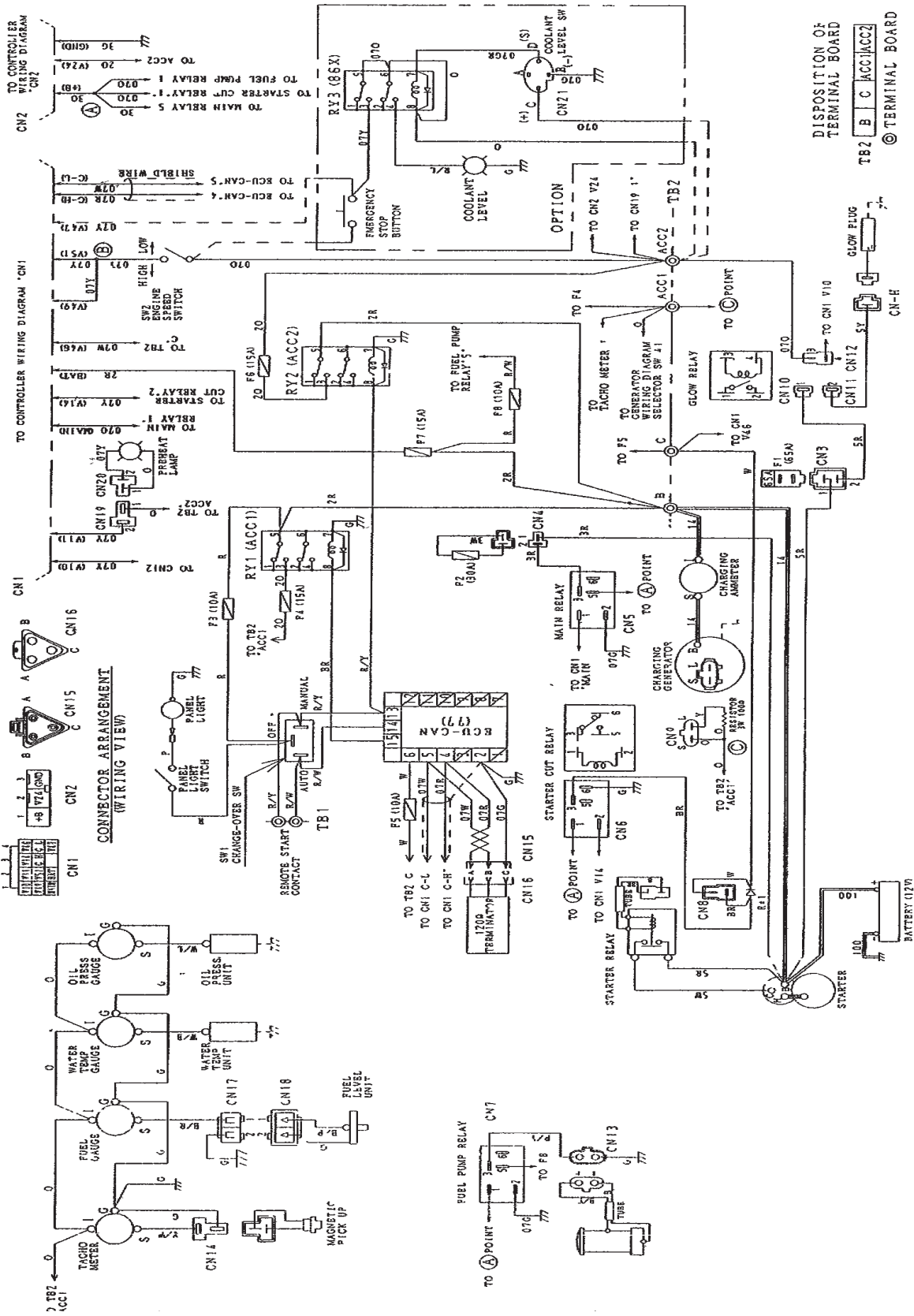

Figure 64. Engine Wiring Diagram

TROUBLESHOOTING (GENERATOR)

Practically all breakdowns can be prevented by proper handling and maintenance inspections, but in the event of a breakdown, use Table 19 shown below for diagnosis of the Generator. If the problem cannot be remedied, consult our company's business office or service plant.

Table 19. Generator Troubleshooting		
Symptom	Possible Problem	Solution
No Voltage Output	AC Voltmeter defective?	Check output voltage using a voltmeter.
	Is wiring connection loose?	Check wiring and repair.
	Is AVR defective?	Replace if necessary.
	Defective Rotating Rectifier?	Check and replace.
	Defective Exciter Field?	Check for approximately 17.3 ohms across J & K on CN1
Low Voltage Output	Is engine speed correct?	Turn engine throttle lever to "High".
	Is wiring connections loose?	Check wiring and repair.
	Defective AVR?	Replace if necessary.
High Voltage Output	Is wiring connections loose?	Check wiring and repair.
	Defective AVR?	Replace if necessary.
Circuit Breaker Tripped	Short Circuit in load?	Check load and repair.
	Over current?	Confirm load requirements and reduce.
	Defective circuit breaker?	Check and replace.
	Over current Relay actuated?	Confirm load requirement and replace.

TROUBLESHOOTING (ENGINE CONTROLLER)

Practically all breakdowns can be prevented by proper handling and maintenance inspections, but in the event of a breakdown, use Table 20 (Engine Controller Troubleshooting) as a basic guideline for troubleshooting the Microprocessor Engine Controller unit (MPEC). If the problem cannot be remedied, consult our company's business office or service plant.

Table 20. Engine Controller Troubleshooting (MPEC)		
Symptom	Possible Problem	Solution
Low oil pressure light is on.	Low oil level?	Fill oil level.
	Oil pressure sending unit failure?	Replace oil pressure sending unit.
	Time delay malfunction in controller?	Refer to dealer.
	Wire shorted?	Inspect/repair wire.
High coolant temperature light is on.	Fan belt tension incorrect?	Tighten/replace fan belt.
	Air flow is not circulating through radiator?	Clean/repair radiator grill.
	Doors open?	Close doors.
	Exhaust leaking?	Replace/repair gaskets or faulty part.
	Generator being overloaded?	Check/reduce load.
	Thermostat failure?	Replace thermostat.
	Air intake blocked?	Clean all air intakes.
Overcrank light is on.	Temperature switch failure	Replace temperature switch.
	No or low fuel?	Fill fuel level.
Overspeed light is on.	Controller needs to be calibrated?	Refer to dealer.
	RPM engine speed too high?	Adjust RPM.
	Governor actuator needs to be adjusted?	Adjust governor actuator.
	Governor controller needs to be adjusted?	Adjust governor controller.
Overspeed and engine start lights are on at same time.	Engine controller needs to be calibrated?	Refer to dealer.
	Magnetic pickup out of adjustment?	Adjust magnetic pickup.
	Magnetic pickup dirty?	Clean magnetic pickup.
	Is magnetic pickup cable connected?	Inspect magnetic pickup cable and connect cable securely.

TROUBLESHOOTING (DIAGNOSTIC LAMP)

The engine controller of this generator diagnoses problems that arise from the engine control system and the engine itself. Press the diagnostic button (Figure 67) on the diagnostic panel to determine if an engine malfunction has occurred.

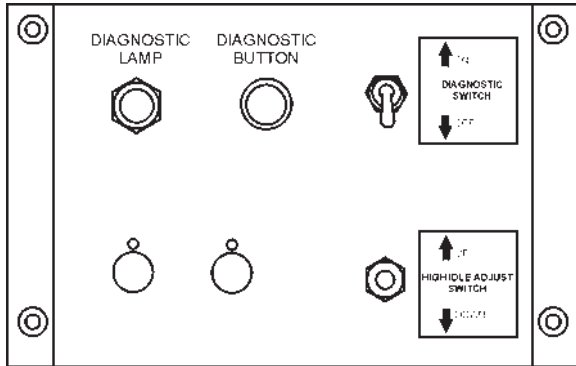

Figure 66. Diagnostic Panel

METHOD OF OPERATION

1. Normally, the diagnostic lamp will be **dimly** lit when the **MPEC Control Switch** is placed in the **MANUAL** position.
2. If engine trouble occurs, the diagnostic lamp will be **brightly** lit as long as the control switch is left in the manual position.
3. The diagnostic lamp will indicate that an engine malfunction has occurred.

NOTICE

For a complete understanding of error codes and troubleshooting procedures, refer to the enclosed engine instruction manual.

NOTICE

If the engine is cranked while the diagnostic switch is in the "ON" position, the engine will not be stopped even if the starter switch is turned to the "OFF" position. In such case, turn the diagnostic switch to the "OFF" position.

EXPLANATION OF CODE IN REMARKS COLUMN

The following section explains the different symbols and remarks used in the Parts section of this manual. Use the help numbers found on the back page of the manual if there are any questions.

NOTICE

The contents and part numbers listed in the parts section are subject to change **without notice**. Multiquip does not guarantee the availability of the parts listed.

SAMPLE PARTS LIST

NO.	PART NO.	PART NAME	QTY.	REMARKS
1	12345	BOLT.....	1	INCLUDES ITEMS W/%
2%		WASHER, 1/4 IN.....		NOT SOLD SEPARATELY
2%	12347	WASHER, 3/8 IN....	1	MQ-45T ONLY
3	12348	HOSE	A/R	MAKE LOCALLY
4	12349	BEARING	1	S/N 2345B AND ABOVE

NO. Column

Unique Symbols — All items with same unique symbol

(@, #, +, %, or >) in the number column belong to the same assembly or kit, which is indicated by a note in the “Remarks” column.

Duplicate Item Numbers — Duplicate numbers indicate multiple part numbers, which are in effect for the same general item, such as different size saw blade guards in use or a part that has been updated on newer versions of the same machine.

NOTICE

When ordering a part that has more than one item number listed, check the remarks column for help in determining the proper part to order.

PART NO. Column

Numbers Used — Part numbers can be indicated by a number, a blank entry, or TBD.

TBD (To Be Determined) is generally used to show a part that has not been assigned a formal part number at the time of publication.

A blank entry generally indicates that the item is not sold separately or is not sold by Multiquip. Other entries will be clarified in the “Remarks” Column.

QTY. Column

Numbers Used — Item quantity can be indicated by a number, a blank entry, or A/R.

A/R (As Required) is generally used for hoses or other parts that are sold in bulk and cut to length.

A blank entry generally indicates that the item is not sold separately. Other entries will be clarified in the “Remarks” Column.

REMARKS Column

Some of the most common notes found in the “Remarks” Column are listed below. Other additional notes needed to describe the item can also be shown.

Assembly/Kit — All items on the parts list with the same unique symbol will be included when this item is purchased.

Indicated by:

“INCLUDES ITEMS W/(unique symbol)”

Serial Number Break — Used to list an effective serial number range where a particular part is used.

Indicated by:

“S/N XXXXX AND BELOW”

“S/N XXXX AND ABOVE”

“S/N XXXX TO S/N XXX”

Specific Model Number Use — Indicates that the part is used only with the specific model number or model number variant listed. It can also be used to show a part is NOT used on a specific model or model number variant.

Indicated by:

“XXXXX ONLY”

“NOT USED ON XXXX”

“Make/Obtain Locally” — Indicates that the part can be purchased at any hardware shop or made out of available items. Examples include battery cables, shims, and certain washers and nuts.

“Not Sold Separately” — Indicates that an item cannot be purchased as a separate item and is either part of an assembly/kit that can be purchased, or is not available for sale through Multiquip.

SUGGESTED SPARE PARTS

DCA125SSIU WHISPERWATT GENERATOR WITH ISUZU 4HK1X DIESEL ENGINE

1 to 3 units

<u>QTY.</u>	<u>P/N</u>	<u>DESCRIPTION</u>
1.....	M3310502203.....	RADIATOR HOSE, UPPER
1.....	M3310502303.....	RADIATOR HOSE, LOWER
5.....	1132402322.....	FILTER, OIL
5.....	0602042590.....	FILTER, FUEL (MAIN)
5.....	8980088400.....	ELEMENT, FUEL (MAIN)
5.....	8980758540.....	ELEMENT, FUEL (PRE)
5.....	8980714010.....	FILTER, FUEL (FEED PUMP)
2.....	0605505070.....	CAP, FUEL
5.....	0602046684.....	ELEMENT, AIR CLEANER, OUTER
5.....	0602046685.....	ELEMENT, AIR CLEANER, INNER
1.....	0602122272.....	UNIT, OIL PRESSURE
1.....	0602123260.....	UNIT, WATER TEMPERATURE
1.....	0601810245.....	BULB, ALARM LAMP
1.....	8980527130.....	V-BELT
1.....	0601870440.....	CIRCUIT BREAKER, 1P, 120V@ 20A
1.....	0601870441.....	CIRCUIT BREAKER, 2P, 250V@ 50A
1.....	LY2DUS12VDC	RELAY
2.....	0601806644.....	FUSE, 30A
2.....	0601806640.....	FUSE, 65A

GENERATOR ASSY.

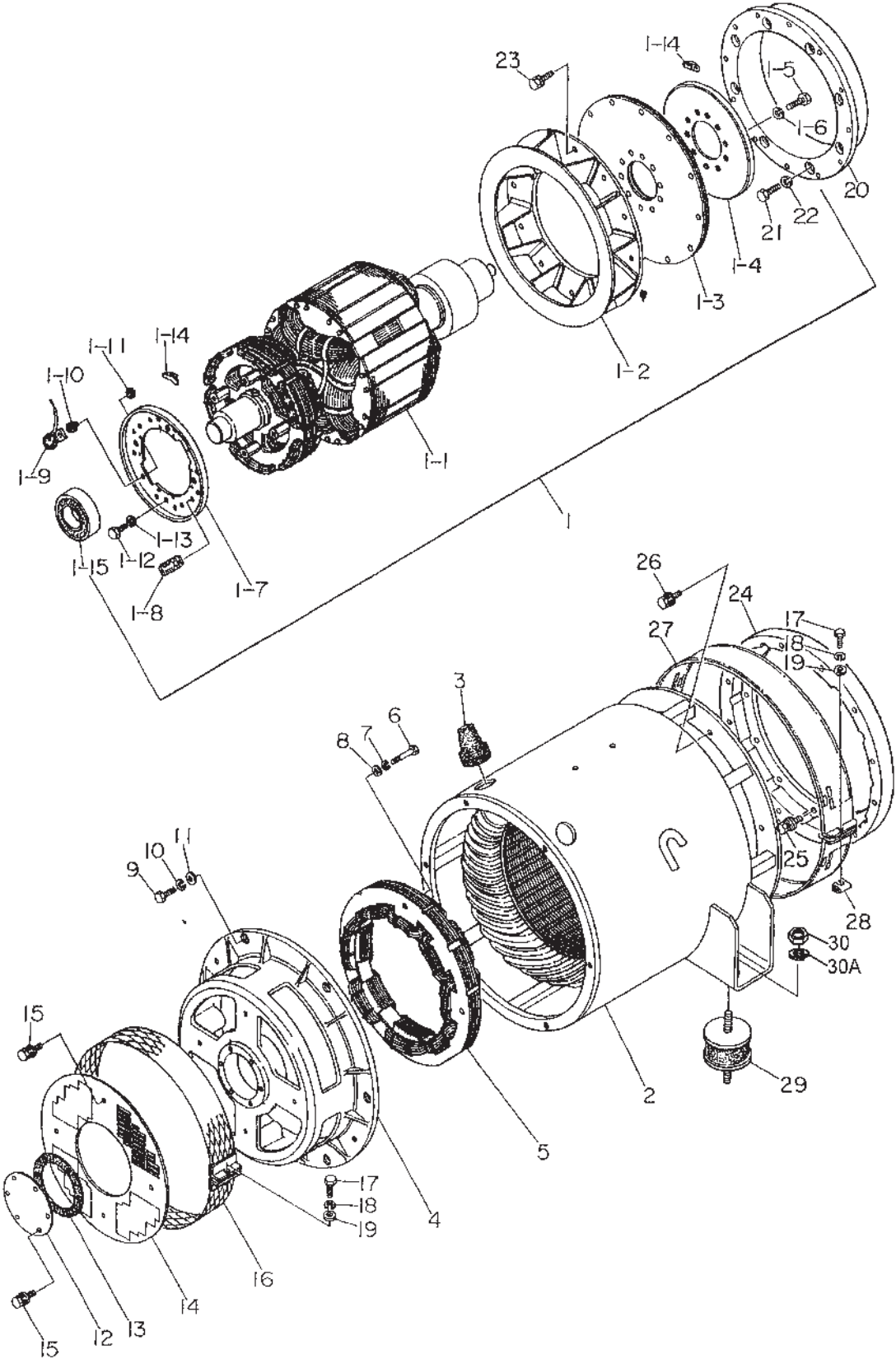

GENERATOR ASSY.

<u>NO.</u>	<u>PART NO.</u>	<u>PART NAME</u>	<u>QTY.</u>	<u>REMARKS</u>
1	C0110001002	ROTOR ASSY	1	
*1-1		FIELD ASSY	1	
1-2	8131070013	FAN	1	
1-3	8131611014	COUPLING DISK	8	
1-4	8131015003	BALANCING PLATE.....	1	PURCHASE ITEMS 1-14 AS A SET
1-5	0012112035	HEX HEAD BOLT	10	
1-6	0042612000	WASHER, LOCK	10	
1-7	8101026013	RECTIFIER SET PLATE	1	PURCHASE ITEMS 1-14 AS A SET
1-8	0601821349	RECTIFIER	2	
1-9	0601822601	SURGE ABSORBER	1	
1-10	8001020004	INSULATOR WASHER	1	
1-11	8001020504	INSULATOR WASHER	1	
1-12	0010110020	HEX HEAD BOLT	4	
1-13	0040010000	WASHER, LOCK	4	
1-14	0601000209	BALANCING WEIGHT KIT	1	
1-15	0071906312	BEARING	1	
2	C0130000503	STARTER ASSY	1	
3	0845041804	GROMMET	2	
4	8131315202	END BRACKET	1	
5	8101350013	EXCITER FIELD ASSY	1	
6	0012110060	HEX HEAD BOLT	4	
7	0042610000	WASHER, LOCK	4	
8	0041210000	WASHER, FLAT	4	
9	0010112035	HEX HEAD BOLT	6	
10	0040012000	WASHER, LOCK	6	
11	0041212000	WASHER, FLAT	6	
12	8131310104	BEARING COVER	1	
13	8131312204	BEARING GASKET	1	
14	8131331003	END BRACKET COVER	1	
15	0017106012	HEX HEAD BOLT	10	
16	8101333003	END BRACKET COVER	1	
17	0010106030	HEX HEAD BOLT	2	
18	0040006000	WASHER, LOCK	2	
19	0041206000	WASHER, FLAT	2	
20	M3163400503	COUPLING RING	1	
21	0010310075	HEX HEAD BOLT	8	
22	0042510000	WASHER, LOCK	8	
23	0012810030	HEX HEAD BOLT	12	
24	M3163600003	COUPLING ADAPTER	1	
25	0012810030	HEX HEAD BOLT	12	
26	0012810030	HEX HEAD BOLT	12	
27	8131332014	FAN COVER	1	
28	0600815000	NUT	1	
29	0605000063	RUBBER SUSPENSION	2	
30	0030016000	HEX NUT	2	
30A	0040016000	WASHER, LOCK	2	

CONTROL BOX ASSY.

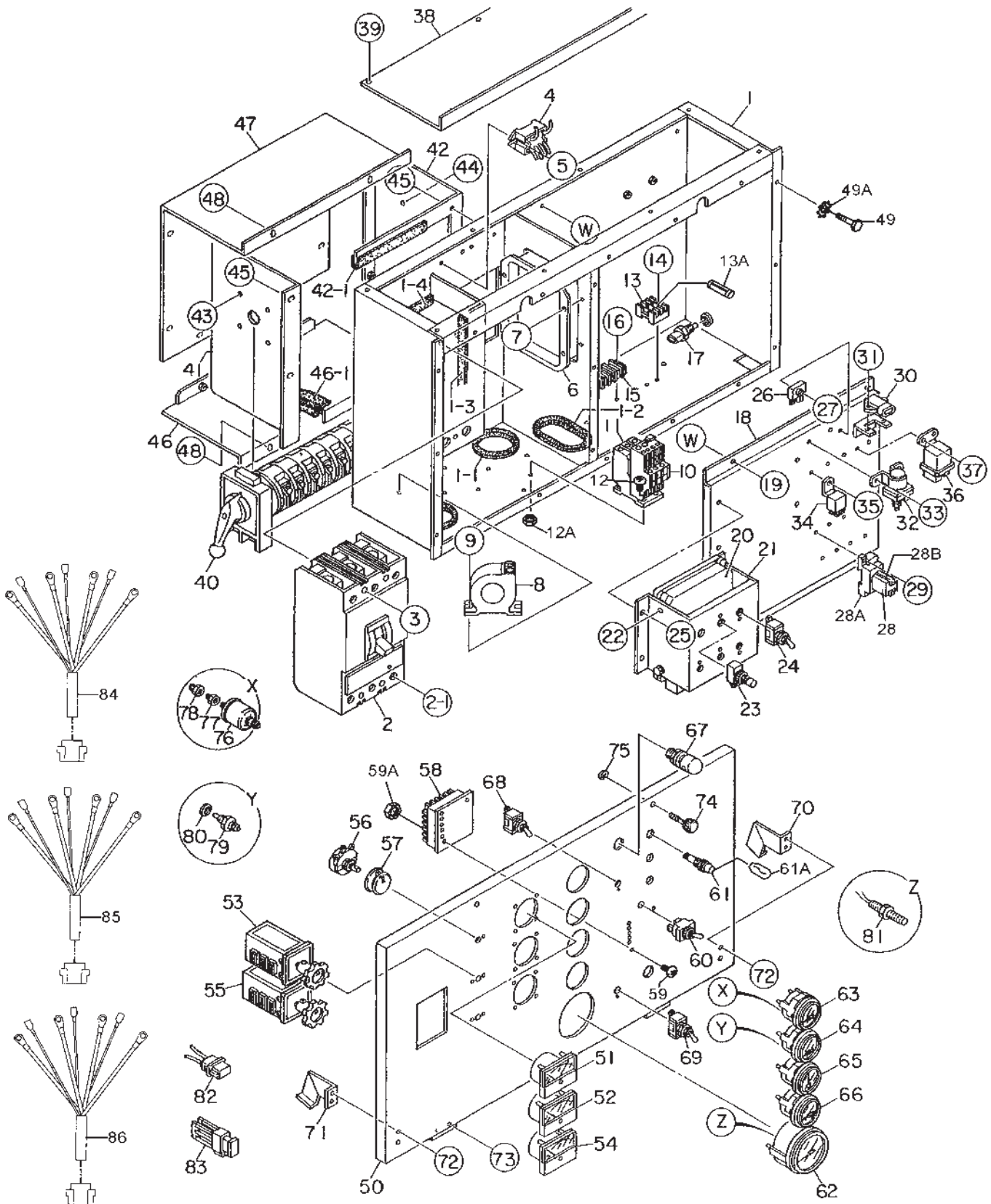

CONTROL BOX ASSY.

<u>NO.</u>	<u>PART NO.</u>	<u>PART NAME</u>	<u>QTY.</u>	<u>REMARKS</u>
1	M3213001702	CONTROL BOX	1	
1-1	0330000210	EDGING	2	
1-2	0330000280	EDGING	1	
1-3	0330000180	EDGING	1	
1-4	0330000160	EDGING	2	
2	0601808823	CIRCUIT BREAKER, 3P 300A	1	
2-1	0342604120	HEX SOCKET HEAD CAP SCREW	6	
3	0021006080	MACHINE SCREW	4	
4	0601823863	RELAY UNIT	2	
5	0027104016	MACHINE SCREW	4	
6	0601820671	AUTOMATIC VOLTAGE REGULATOR	1	
7	0027105016	MACHINE SCREW	4	
8	0601801124	CURRENT TRANSFORMER	3	
9	0027106020	MACHINE SCREW	6	
10	0601820847	OVER CURRENT RELAY	1	
11	0601820848	OVER CURRENT RELAY	1	
12	0027104016	MACHINE SCREW	2	
12A	0207004000	HEX NUT	2	
13	0601802218	FUSE HOLDER	1	
13A	0601806671	FUSE, 15A	3	
14	0027103016	MACHINE SCREW	2	
15	0601815153	TERMINAL	1	
16	0027104016	MACHINE SCREW	2	
17	8121468300	INLET AIR TEMP. SENSOR	1	REPLACES P/N 0603210240
18	M3260500503	ELECTRIC PARTS SET PANEL	1	
19	0016906016	HEX HEAD BOLT	4	
20	8980710280	CONTROLLER.....	1	REPLACES P/N 0602202686
21	M3206500604	BRACKET	1	
22	0066906016	HEX HEAD BOLT	4	
23	0601831205	PUSH BUTTON SWITCH	1	
24	0601831330	DIAGNOSTIC SWITCH	1	
25	0016906016	HEX HEAD BOLT	4	
26	0601823240	RECTIFIER	1	
27	0027104030	MACHINE SCREW	1	
28	LY2DUS12VDC	RELAY	2	REPLACES P/N 0601827656
28A	PTF08A	BASE.....	2	REPLACES P/N 0601823109
28B	PYCA1	CLIP	4	REPLACES P/N 0601824400
29	0027104020	MACHINE SCREW	3	
30	8972177780	BAROMETRIC PRESSURE SENSOR	1	REPLACES P/N 0602130220
31	0027104016	MACHINE SCREW	2	
32	5825530444	RELAY STARTER.....	1	REPLACES P/N 0602201402

CONTROL BOX ASSY.

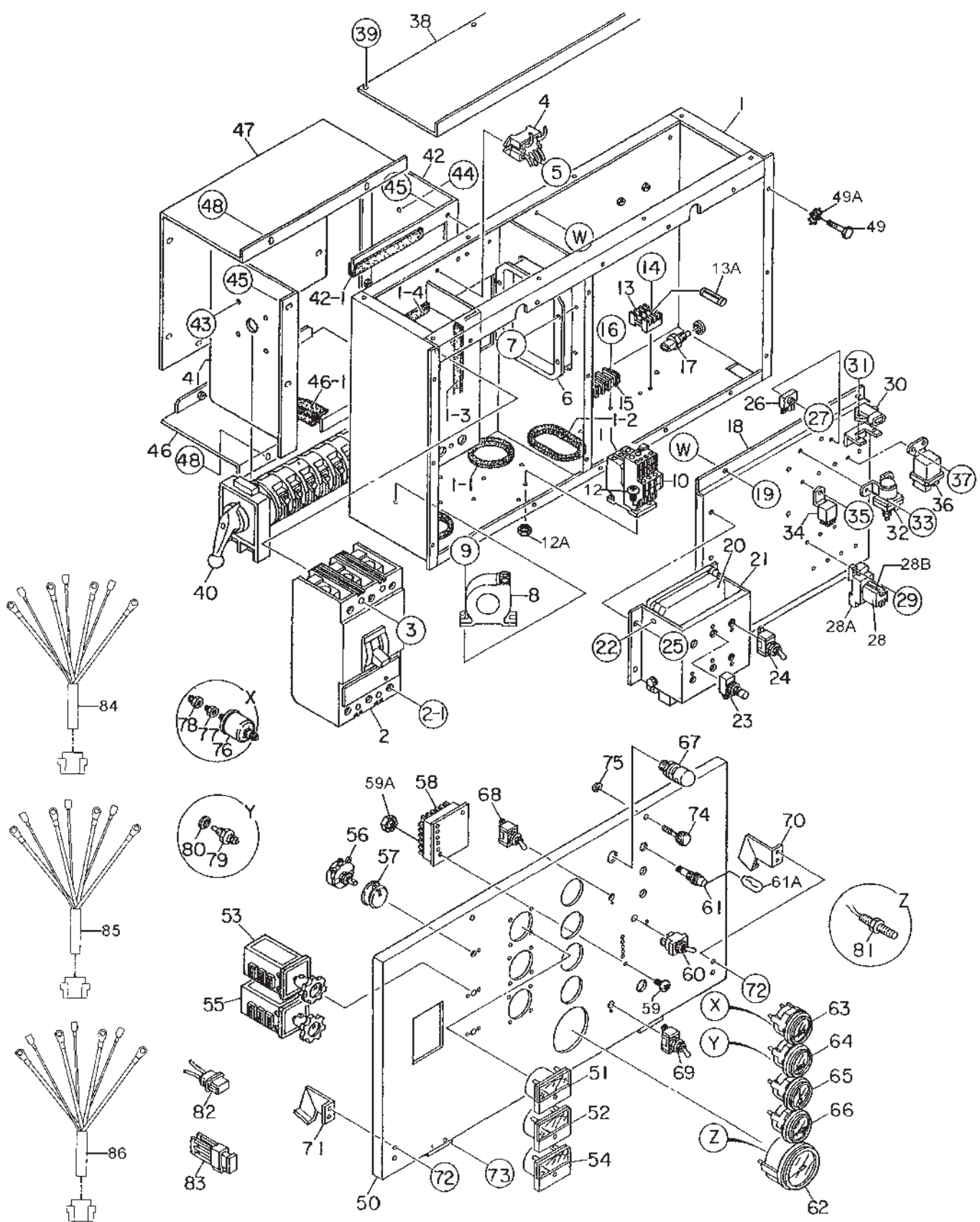

CONTROL BOX ASSY.

<u>NO.</u>	<u>PART NO.</u>	<u>PART NAME</u>	<u>QTY.</u>	<u>REMARKS</u>
33	0027106016	MACHINE SCREW	2	
34	5825500290	RELAY	3	REPLACES P/N 0602201400
35	0027105016	MACHINE SCREW	3	
36	8970119490	GLOW PLUG RELAY	1	REPLACES P/N 0602202685
37	0027105016	MACHINE SCREW	2	
38	M3213500604	CONTROL BOX COVER	1	
39	0016906016	HEX HEAD BOLT	8	
40	M3270100404	SELECTOR SWITCH	1	
41	M3213601504	SWITCH BRACKET	1	
42	M3213601604	SWITCH BRACKET	1	
42-1	0330000170	EDGING	2	
43	0027104035	MACHINE SCREW	4	
43A	0207004000	HEX NUT	4	
44	0027104016	MACHINE SCREW	4	
44A	0207004000	HEX NUT	4	
45	0016906016	HEX HEAD BOLT	6	
46	M3213602404	SWITCH COVER	1	
46-1	0317700180	WEATHER STRIP	1	
47	M3213602304	SWITCH COVER	1	
48	0016906016	HEX HEAD BOLT	10	
49	0016906016	HEX HEAD BOLT	19	
49A	0040506000	TOOTHED WASHER	1	
50	M3223001103	CONTROL PANEL	1	
51	0601807641	FREQUENCY METER, 45~65Hz 240V	1	
52	0601808988	AC AMMETER, 0~200A/400	1	
53	0601801040	AMMETER CHANGE- OVER SWITCH	1	
54	0601806859	AC VOLTMETER, 0~600V	1	
55	0601801041	VOLTMETER CHANGE- OVER SWITCH	1	
56	0601840073	RHEOSTAT VR, 2W 1k OHM	1	
57	0601840121	KNOB	1	
58	0602202641	CONTROLLER	1	
59	0027104040	MACHINE SCREW	2	
59A	0207004000	HEX NUT	2	
60	0601831340	SWITCH	1	
61	0602103092	ALARM LAMP	2	
61A	0601810245	BULB, ALARM LAMP	2	
62	0602120095	TACHOMETER	1	
63	0602122093	OIL PRESSURE GAUGE	1	
64	0602123090	WATER TEMPERATURE GAUGE	1	
65	0602121081	CHARGING AMMETER	1	
66	0602125090	FUEL GAUGE	1	
67	0601810141	PANEL LIGHT	1	
68	0601831330	PANEL LIGHT SWITCH	1	
69	0601831395	ENGINE SPEED SWITCH	1	
70	M1223100004	STOPPER	1	
71	M3223100004	STOPPER	1	

CONTROL BOX ASSY.

<u>NO.</u>	<u>PART NO.</u>	<u>PART NAME</u>	<u>QTY.</u>	<u>REMARKS</u>
72	0027105010	MACHINE SCREW	4	
73	0027105010	MACHINE SCREW	4	
74	M9220100004	SET SCREW	2	
75	0080200007	SNAP RING	2	
76	0602122272	OIL PRESSURE UNIT	1	
77	M9200100004	ADAPTER	1	
78	8943998582	ADAPTER.....	1REPLACES P/N 0602020220
79	0602123260	WATER TEMPERATURE UNIT	1	
80	9095720140	PACKING.....	1REPLACES P/N 0602021109
81	0602120465	TACHOMETER PICK UP	1	
82	0601806644	FUSE, 30A	1	
83	0601806640	FUSE, 65A	1	
84	M3246702804	WIRE HARNESS GENERATOR	1	
85	M3257201702	WIRE HARNESS ENGINE	1	
86	M3357201802	WIRE HARNESS CONTROLLER	1	

ENGINE AND RADIATOR ASSY.

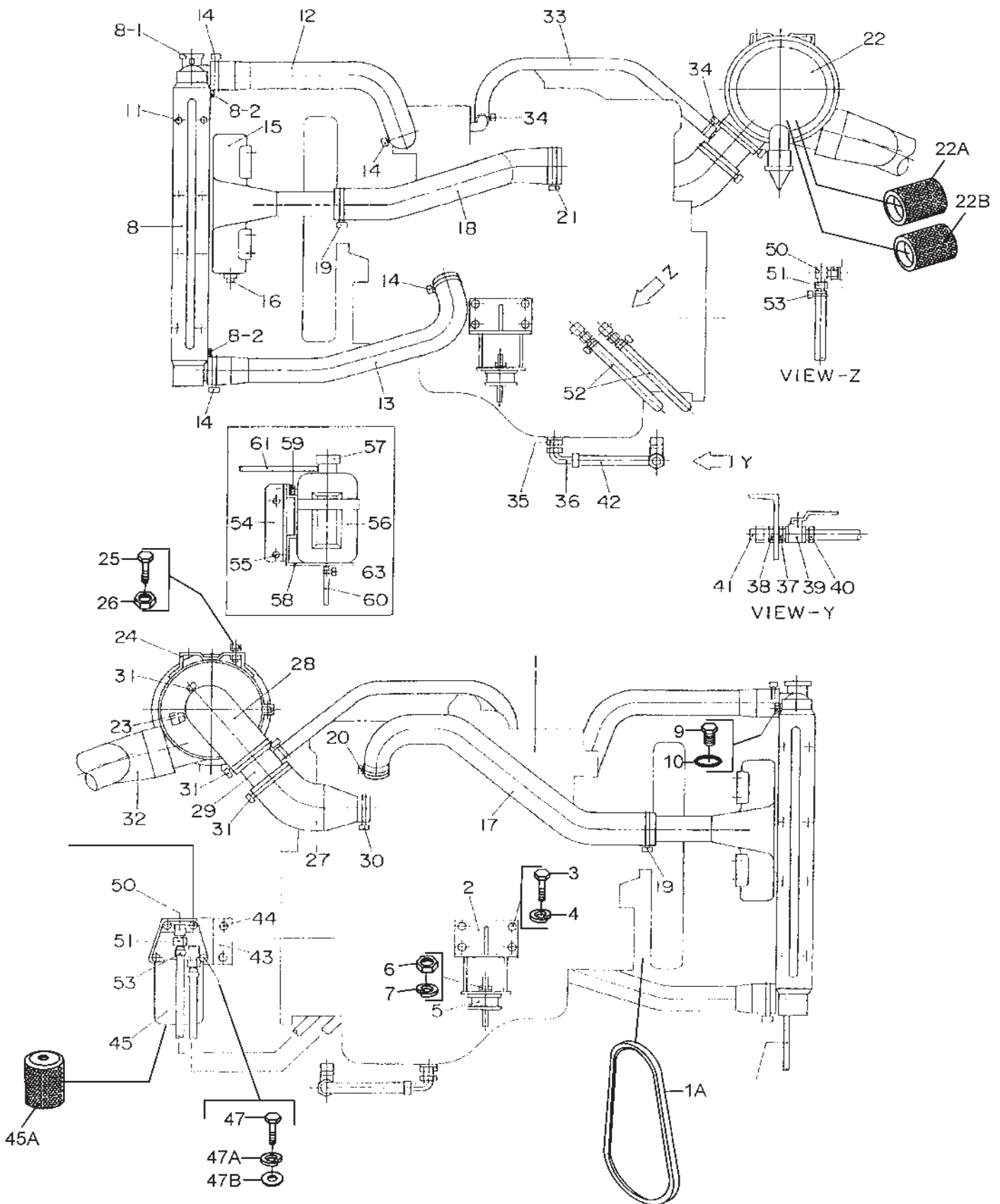

ENGINE AND RADIATOR ASSY.

<u>NO.</u>	<u>PART NO.</u>	<u>PART NAME</u>	<u>QTY.</u>	<u>REMARKS</u>
1	M3923200134	ENGINE, ISUZU 4HK1X	1	
1A	8980527130	FAN BELT	1	REPLACES P/N 0602015253
2	M3303200603	ENGINE FOOT	2	
3	0010310025	HEX HEAD BOLT	8	
4	0040010000	WASHER, LOCK	6	
5	0605000060	RUBBER SUSPENSION	2	
6	0030012000	HEX NUT	2	
7	0040012000	WASHER, LOCK	2	
8	M3923200114	RADIATOR	1	
8-1	0602011029	CAP	1	
8-2	M4492601304	RUBBER SEAL	2	
9	M9200100904	PLUG	1	
10	0150000016	O-RING	1	
11	0016908020	HEX HEAD BOLT	16	
12	M3310502203	RADIATOR HOSE, UPPER	1	
13	M3310502303	RADIATOR HOSE, LOWER	1	
14	0605515148	HOSE BAND	4	
15	M3923200124	INTER COOLER	1	
16	0132004000	PLUG	1	
17	M3310502403	COOLER HOSE	1	
18	M3310502503	COOLER HOSE	1	
19	0605515208	HOSE BAND	2	
20	0605515204	HOSE BAND	1	
21	0605515207	HOSE BAND	1	
22	0602046258	AIR CLEANER	1	
22A	0602046684	AIR CLEANER ELEMENT, OUTER	1	
22B	0602046685	AIR CLEANER ELEMENT, INNER	1	
23	0602040650	AIR CLEANER INDICATOR	1	
24	0602040596	AIR CLEANER BAND	2	
25	0016908020	HEX HEAD BOLT	4	
26	0207008000	HEX NUT	4	
27	M3373101003	AIR CLEANER HOSE	1	
28	M3373101103	AIR CLEANER HOSE	1	
29	M3326100104	BLOWBY PIPE	1	
30	0605515199	HOSE BAND	1	
31	0605515197	HOSE BAND	3	
32	M3373100703	AIR DUCT HOSE	1	
33	0191701200	BLOWBY HOSE	1	
34	0605515149	HOSE BAND	2	
35	0602022581	ADAPTER	1	
36	0602022561	90 DEGREE ELBOW	1	
37	0603306590	CONNECTOR	1	
38	0603300285	ROCKNUT	1	
39	0605511395	VALVE	1	
40	0603306395	HOSE JOINT	1	

ENGINE AND RADIATOR ASSY. (CONTINUED)

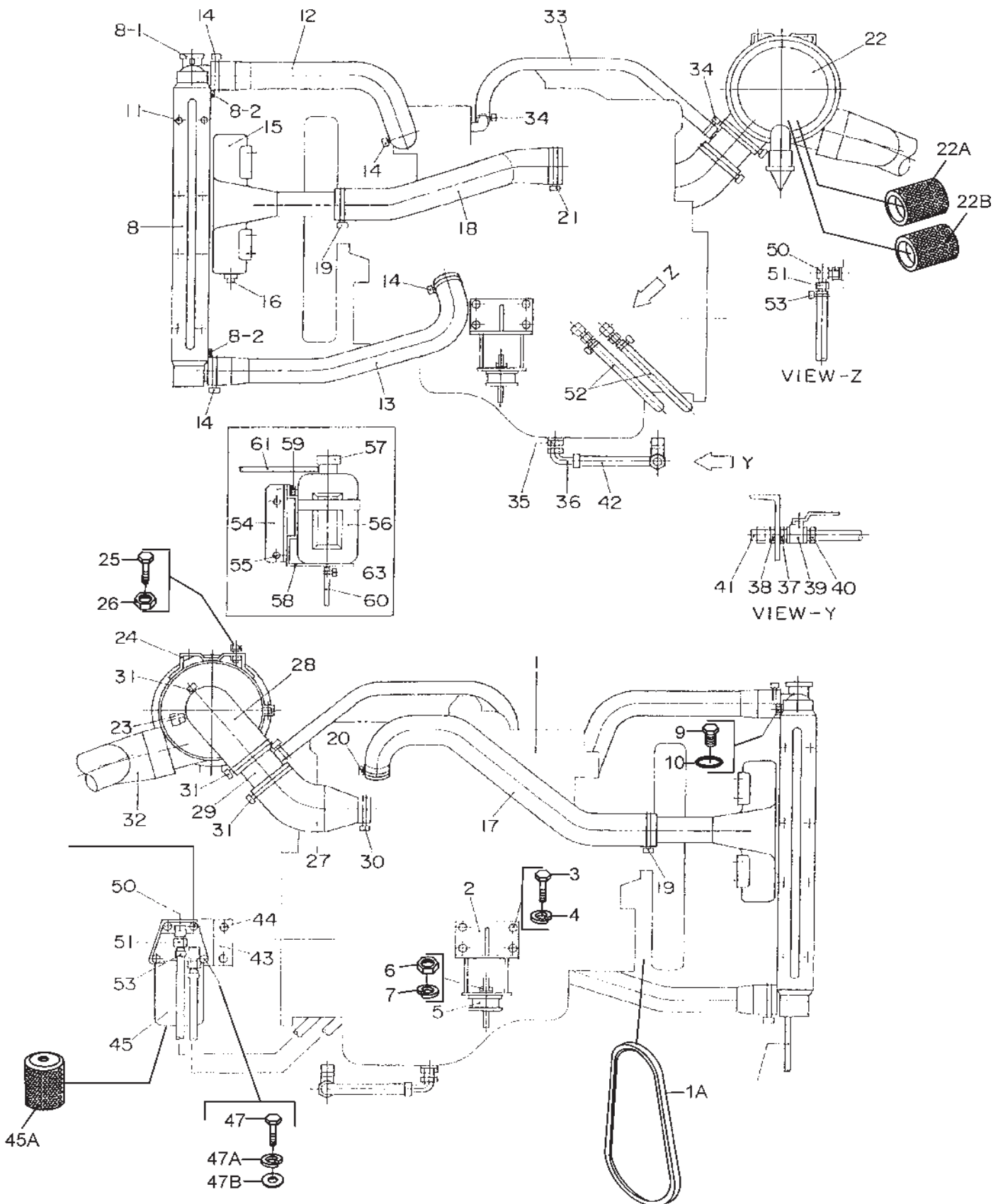

ENGINE AND RADIATOR ASSY. (CONTINUED)

<u>NO.</u>	<u>PART NO.</u>	<u>PART NAME</u>	<u>QTY.</u>	<u>REMARKS</u>
41	0602021070	CAP	1	
42	0269200600	DRAIN HOSE	1	
43	M3323500004	OIL FILTER BRACKET	1	
44	0016910025	HEX HEAD BOLT	2	
45	8973243861	OIL FILTER.....	1	REPLACES P/N 0602041007
45A	1132402322	OIL FILTER CARTRIDGE	1	REPLACES P/N 0602041221
46	0010110120	HEX HEAD BOLT	2	
46A	0040010000	WASHER, LOCK	2	
46B	0041210000	WASHER, FLAT	2	
47	0010110150	HEX HEAD BOLT	2	
47A	0040010000	WASHER, LOCK	2	
47B	0041210000	WASHER, FLAT	2	
50	0602022535	ADAPTER	4	
51	0602022930	HOSE JOINT	4	
52	0192101250	HOSE	2	
53	0605515198	HOSE BAND	4	
54	M3316200004	RESERVE TANK BRACKET	1	
55	0016908020	HEX HEAD BOLT	2	
56	M9300000203	RESERVE TANK	1	
57	0602010900	RESERVE TANK CAP	1	
58	M3316100504	RESERVE TANK BRACKET	1	
59	0016908020	HEX HEAD BOLT	2	
60	0199901050	HOSE	1	
61	0193601200	HOSE	1	
62	0193600450	HOSE	1	
63	0605515106	HOSE BAND	3	

OUTPUT TERMINAL ASSY.

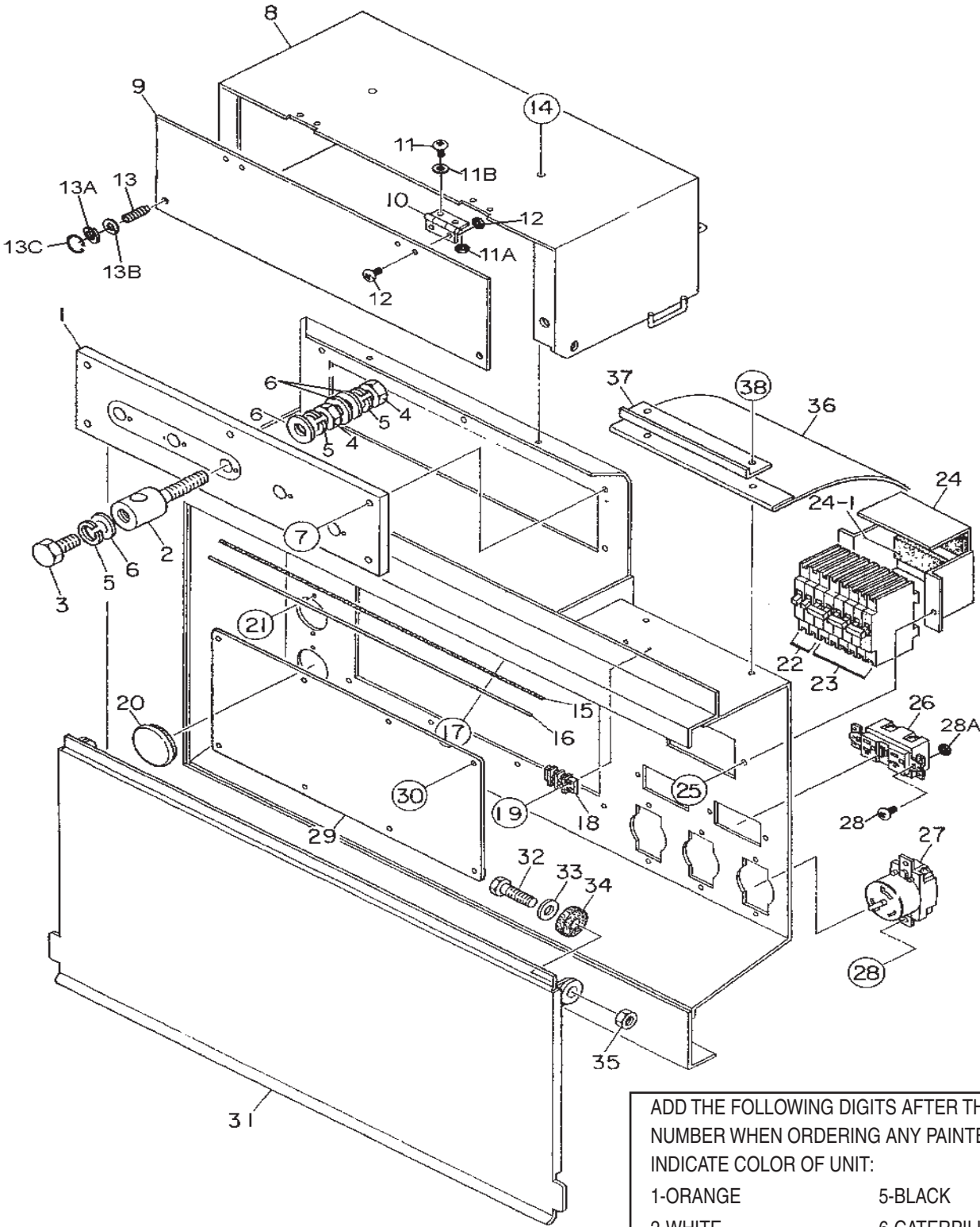

ADD THE FOLLOWING DIGITS AFTER THE PART NUMBER WHEN ORDERING ANY PAINTED PANEL TO INDICATE COLOR OF UNIT:

1-ORANGE	5-BLACK
2-WHITE	6-CATERPILLAR YELLOW
3-SPECTRUM GREY	7-CATO GOLD
4-SUNBELT GREEN	8-RED

THE SERIAL NUMBER MAY BE REQUIRED.

OUTPUT TERMINAL ASSY.

<u>NO.</u>	<u>PART NO.</u>	<u>PART NAME</u>	<u>QTY.</u>	<u>REMARKS</u>
1	M3230700003	TERMINAL BOARD	1	
2	M9220100304	OUTPUT TERMINAL BOLT	5	
3	M9220100404	TIE BOLT	5	
4	0039316000	HEX NUT	10	
5	004001600	WASHER, LOCK	15	
6	0041416000	WASHER, FLAT	20	
7	0016908035	HEX HEAD BOLT	5	
8	M3236100903	TERMANAL COVER	1	
9	M3236100104	OUTPUT WINDOW	1	
10	0605010040	HINGE	2	
11	0027103010	MACHINE SCREW	4	
11A	0030003000	HEX NUT	4	
11B	0041203000	WASHER, FLAT	4	
12	0027103010	MACHINE SCREW	4	
12A	0030003000	HEX NUT	4	
13	M9220100804	SET SCREW	2	
13A	0040006000	WASHER, LOCK	2	
13B	0041206000	WASHER, FLAT	2	
13C	0080200005	RETAINING RING	2	
14	0016906016	HEX HEAD BOLT	4	
15	M3236400004	OUTLET COVER CABLE	1	
16	M3236300004	CABLE OUTLET COVER SUPPORTER	1	
17	0016906020	HEXHEAD BOLT	6	
18	0601815194	TERMINAL BLOCK	1	
19	0027104016	MACHINE SCREW	2	
20	0603306775	BLIND PLUG	2	
21	0027104016	MACHINE SCREW	4	
22	0601870440	CIRCUIT BREAKER, 1P 20A	3	
23	0601870441	CIRCUIT BREAKER, 2P 50A	3	
24	M1260700504	BREAKER COVER FITTING	1	
24-1	0222100100	RUBBER CUSHION	2	
25	0016906020	HEX HEAD BOLT	2	
26	0601812598	RECEPTACLE, GFCI 125V 20AX2	2	
27	0601812538	RECEPTACLE, CS6369 250V 50A	3	
28	0027104016	MACHINE SCREW	10	
28A	0207004000	HEX NUT	10	
29	M3236400204	COVER	1	
30	0016906016	HEX HEAD BOLT	8	
31	M3236100213	TERMINAL COVER	1	
32	0010112045	HEX HEAD BOLT	2	
33	0041212000	WASHER, FLAT	2	
34	M9310200004	RUBBER STAY	2	
35	0030012000	HEX NUT	2	
36	M4236100604	COVER	1	
37	M4236400304	BRACKET	1	
38	0019206015	HEX HEAD BOLT	2	

BATTERY ASSY.

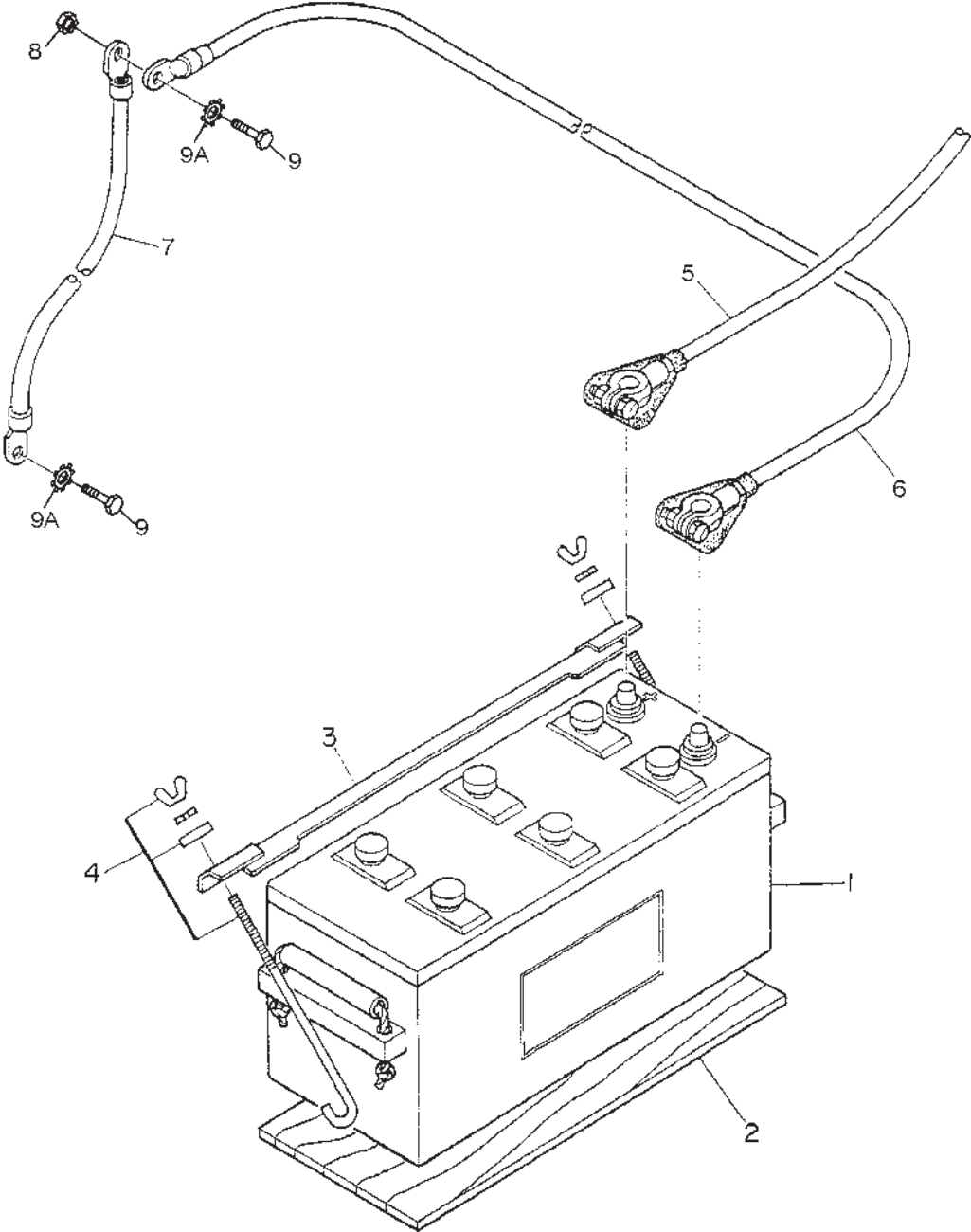

BATTERY ASSY.

<u>NO.</u>	<u>PART NO.</u>	<u>PART NAME</u>	<u>QTY.</u>	<u>REMARKS</u>
1	0602220198	BATTERY	1	
2	M9310500404	BATTERY SHEET	1	
3	M9103000504	BATTERY BAND	1	
4	0602220921	BATTERY BOLT SET	2	
5	M3346901404	BATTERY CABLE	1	
5	M3346901504	BATTERY CABLE	1	
7		CABLE.....	1MAKE LOCALLY
8	0030010000	HEX NUT	1	
8A	0040010000	WASHER, LOCK	1	
9	0017110030	HEX HEAD BOLT	2	
9A	0040510000	TOOTHED WASHER	2	

MUFFLER ASSY.

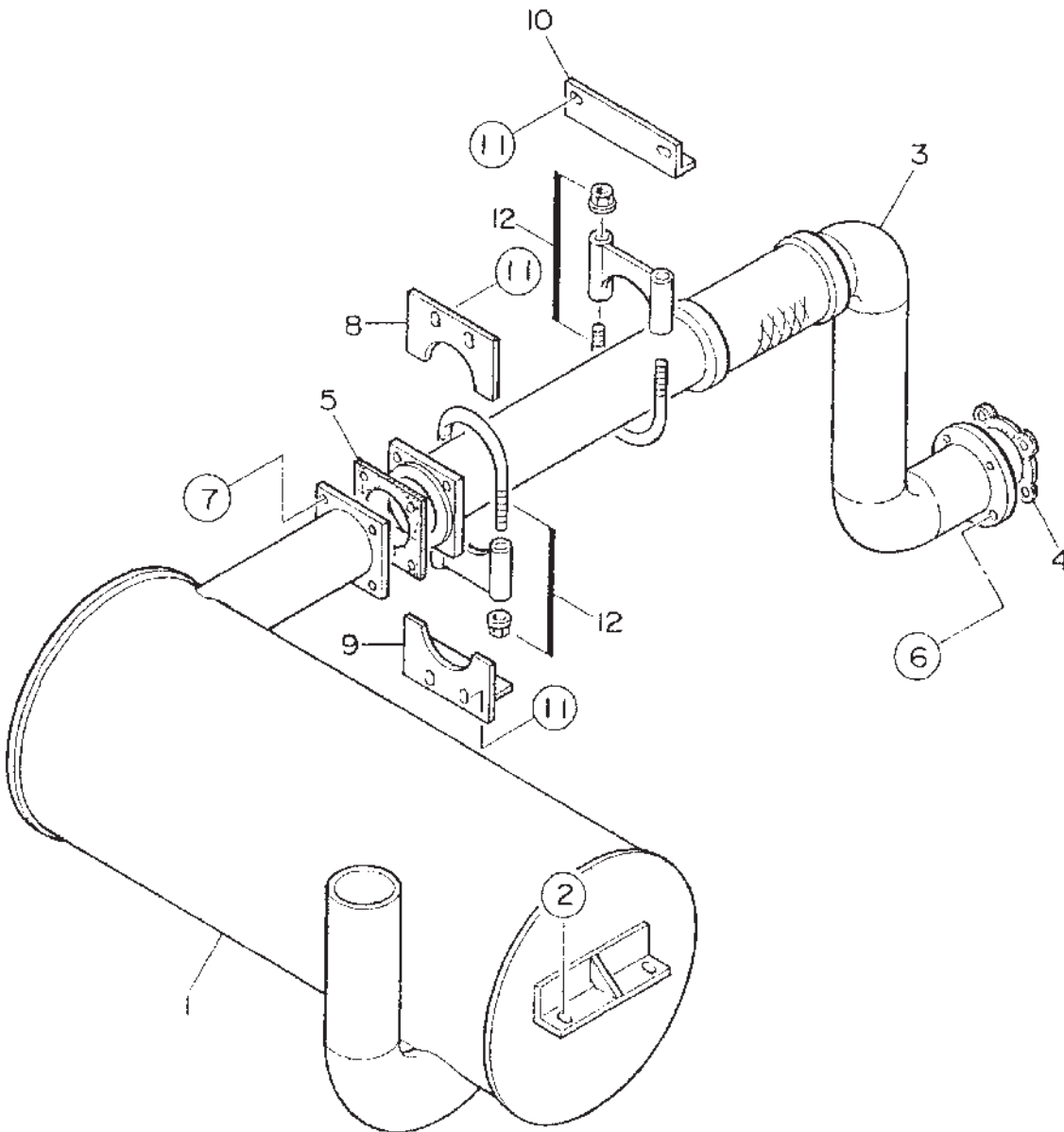

MUFFLER ASSY.

<u>NO.</u>	<u>PART NO.</u>	<u>PART NAME</u>	<u>QTY.</u>	<u>REMARKS</u>
1	M3330100902	MUFFLER	1	
2	0016910025	HEX HEAD BOLT	4	
3	M3333001403	EXHAUST PIPE	1	
4	1141451840	GASKET	1	REPLACES P/N 0602320108
5	M3333200004	GASKET	1	
6	0039308000	HEX NUT	8	
7	0017110040	HEX HEAD BOLT	4	
8	M3330400304	COVER	1	
9	M3330400403	BRACKET	1	
10	M3333300304	BRACKET	1	
11	0016908020	HEX HEAD BOLT	6	
12	0602326061	U-BOLT SET	2	

FUEL TANK ASSY.

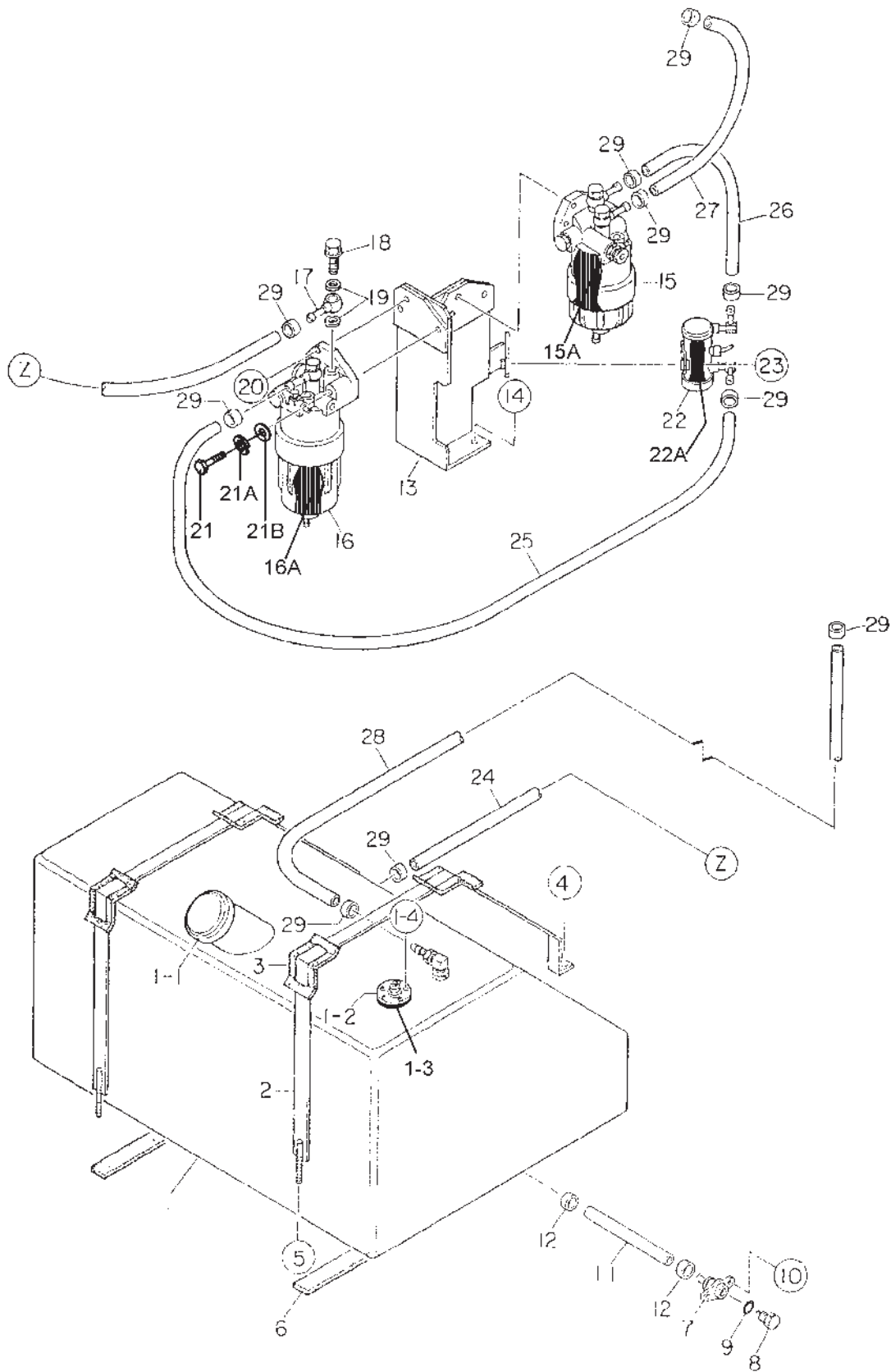

FUEL TANK ASSY.

<u>NO.</u>	<u>PART NO.</u>	<u>PART NAME</u>	<u>QTY.</u>	<u>REMARKS</u>
1	M3363002002	FUEL TANK	1	
1-1	0605505070	FUEL TANK CAP	1	
1-2	0605501076	FUEL SENDER UNIT	1	
1-3	0605516090	GASKET	1	
1-4	0027104015	MACHINE SCREW	5	
2	M3363200204	TANK BAND	4	
3	M9310500104	SUPPORTER SHEET	4	
4	0016908020	HEX HEAD BOLT	2	
5	0207308000	SUPER LOCK NUT	2	
6	0222100150	RUBBER SHEET	4	
7	M9200000003	DRAIN JOINT	1	
8	M9200200004	DRAIN BOLT	1	
9	0150000018	O RING	1	
10	0016906020	HEX HEAD BOLT	2	
11	M1363400104	DRAIN HOSE	1	
12	0605515198	HOSE BAND	2	
14	0016908020	HEX HEAD BOLT	4	
15	8980139861	MAIN FUEL FILTER	1	REPLACES P/N 0602042426
15A	8980088400	FUEL FILTER ELEMENT	1	REPLACES P/N 0602042515
16	8980758550	PRE. FUEL FILTER	1	REPLACES P/N 0602042405
16A	8980758540	FUEL FILTER ELEMENT	1	REPLACES P/N 0602042516
17	8973834270	JOINT PIPE	4	REPLACES P/N 0602042661
18	1096750951	JOINT BOLT	4	REPLACES P/N 0602042621
19	1096300860	PACKING	8	REPLACES P/N 0602042641
20	0017110040	HEX HEAD BOLT	4	
21	0010110070	HEX HEAD BOLT	2	
21A	0040010000	WASHER, LOCK	2	
21B	0041210000	WASHER, FLAT	2	
22	8980682750	FUEL FEED PUMP	1	REPLACES P/N 0602023240
22A	8980714010	FILTER, FUEL FEED PUMP	1	REPLACES P/N 0602042517
23	0016906025	HEX HEAD BOLT	2	
24	0191301400	SUCTION HOSE	1	
25	0191300800	SUCTION HOSE	1	
26	0191300280	SUCTION HOSE	1	
27	0191300500	SUCTION HOSE	1	
28	0191303400	RETURN HOSE	1	
29	0605515109	HOSE BAND	10	

ENCLOSURE ASSY.

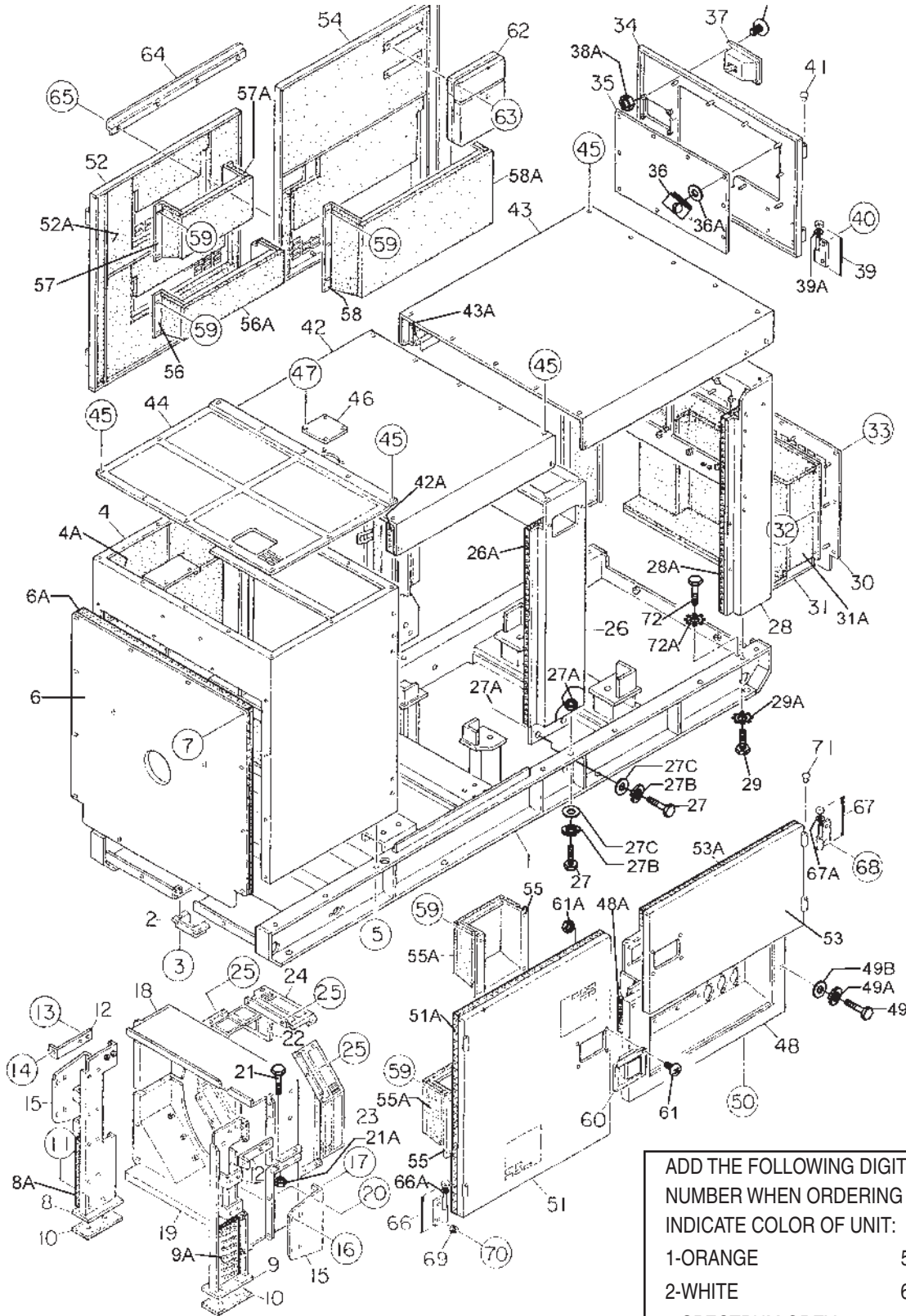

ADD THE FOLLOWING DIGITS AFTER THE PART NUMBER WHEN ORDERING ANY PAINTED PANEL TO INDICATE COLOR OF UNIT:

- | | |
|-----------------|----------------------|
| 1-ORANGE | 5-BLACK |
| 2-WHITE | 6-CATERPILLAR YELLOW |
| 3-SPECTRUM GREY | 7-CATO GOLD |
| 4-SUNBELT GREEN | 8-RED |

THE SERIAL NUMBER MAY BE REQUIRED.

ENCLOSURE ASSY.

<u>NO.</u>	<u>PART NO.</u>	<u>PART NAME</u>	<u>QTY.</u>	<u>REMARKS</u>
1	M3413002402	BASE	1	
2	M1413400004	COVER	1	
3	0016908020	HEX HEAD BOLT	2	
4	M3423002702	FRONT FRAME	1	
4A	M3493114303	ACOUSTIC SHEET	1	
5	0016910025	HEX HEAD BOLT	6	
6	M3423200104	FRONT FRAME COVER	1	
6A	M3493100304	ACOUSTIC SHEET	1	
7	0019208020	HEX HEAD BOLT	14	
8	M3310202203	RADIATOR SUPPORTER	1	
8A	M3493600504	ACOUSTIC SHEET	1	
9	M3310202303	RADIATOR SUPPORTER	1	
9A	M3493600504	ACOUSTIC SHEET	1	
10	M4310600304	RUBBER SHEET	2	
11	0017112055	HEX HEAD BOLT	4	
12	M3310202504	RADIATOR BRACKET	2	
13	0016910025	HEX HEAD BOLT	4	
14	0016910025	HEX HEAD BOLT	2	
15	M3310202403	INTER COOLER BRACKET	2	
16	0016910025	HEX HEAD BOLT	8	
17	0017110020	HEX HEAD BOLT	8	
18	M3310303303	FAN SHROUD	1	
19	M3310303403	FAN SHROUD	1	
20	0016908020	HEX HEAD BOLT	8	
21	0016908020	HEX HEAD BOLT	4	
21A	0207008000	HEX NUT	4	
22	M3310303603	FAN GUARD	1	
23	M3310303503	FAN GUARD	1	
24	M3310303703	FAN GUARD	1	
25	0016908020	HEX HEAD BOLT	16	
26	M3433001302	CENTER FRAME	1	
26A	M3493200004	ACOUSTIC SHEET	1	
27	0010114040	HEX HEAD BOLT	12	
27A	0030014000	HEX NUT	12	
27B	0040014000	WASHER, LOCK	24	
27C	0031214000	WASHER, FLAT	24	
28	M3443001802	REAR FRAME	1	
28A	M3493300204	ACOUSTIC SHEET	1	
29	0016910030	HEX HEAD BOLT	4	
29A	0040510000	TOOTHED WASHER	1	
30	M3443301603	REAR COVER	1	
31	M3443301703	REAR COVER DUCT	2	
31A	M3493308503	ACOUSTIC SHEET	1	
32	0207006000	HEX NUT	9	

ENCLOSURE ASSY. (CONTINUED)

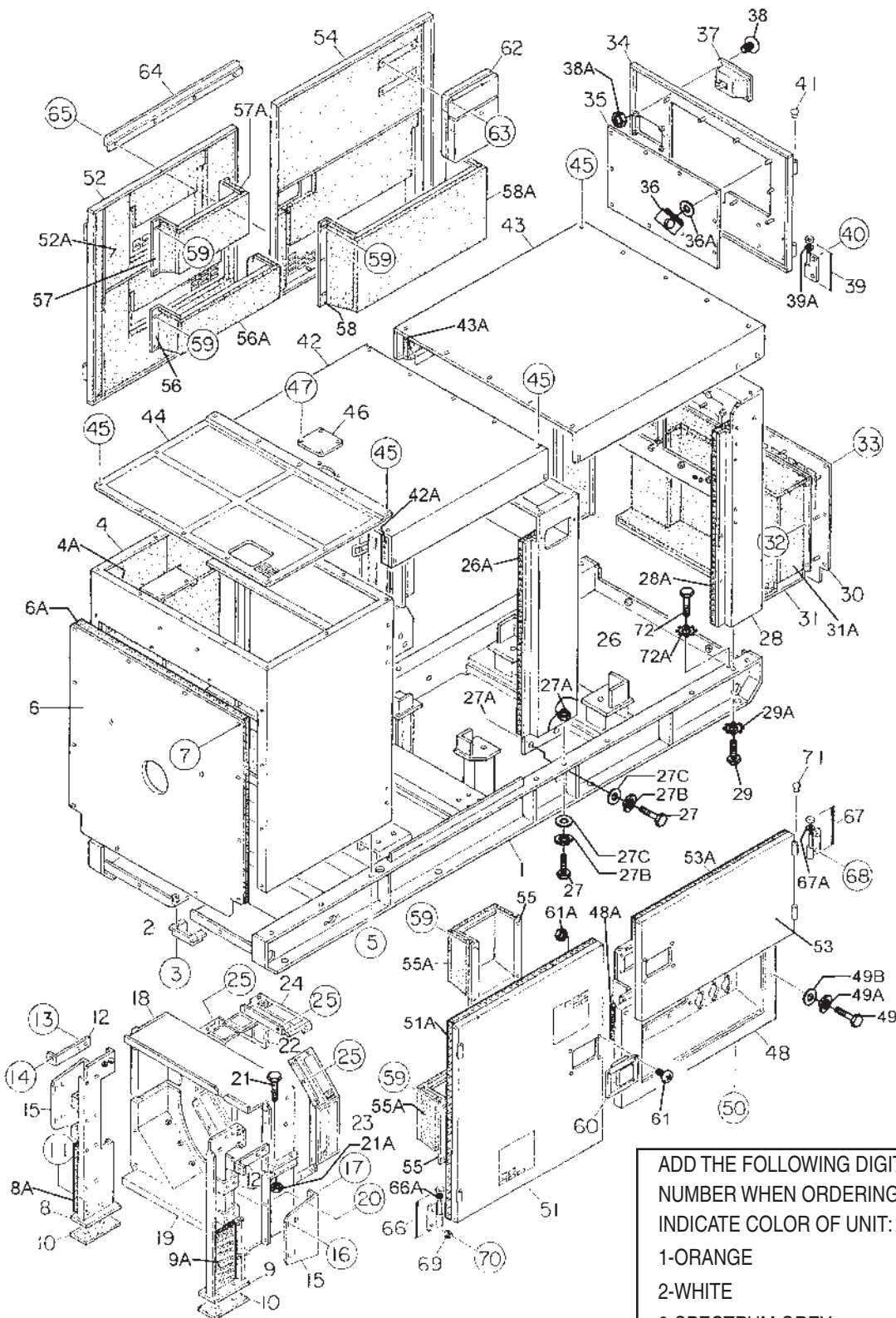

ADD THE FOLLOWING DIGITS AFTER THE PART NUMBER WHEN ORDERING ANY PAINTED PANEL TO INDICATE COLOR OF UNIT:

1-ORANGE	5-BLACK
2-WHITE	6-CATERPILLAR YELLOW
3-SPECTRUM GREY	7-CATO GOLD
4-SUNBELT GREEN	8-RED

THE SERIAL NUMBER MAY BE REQUIRED.

ENCLOSURE ASSY. (CONTINUED)

<u>NO.</u>	<u>PART NO.</u>	<u>PART NAME</u>	<u>QTY.</u>	<u>REMARKS</u>
33	0019208020	HEX HEAD BOLT	10	
34	M3443200703	REAR DOOR	1	
35	M3443600104	WINDOW PLATE	1	
36	0037906000	SELF- LOCKING U NUT	10	
36A	0041206000	WASHER, FLAT	10	
37	M9113000002	DOOR HANDLE ASSY	1	
38	0021806016	MACHINE SCREW	4	
38A	0030006000	HEX NUT	4	
39	M9110100204	HINGE	2	
39A	M9116100004	WASHER	2	
40	0019208020	HEX HEAD BOLT	3	
41	M9310000004	BLIND PLUG	2	
42	M3463101403	ROOF PANEL	1	
42A	M3493508803	ACOUSTIC SHEET	1	
43	M3463201902	ROOF PANEL	1	
44	M3423202503	FRONT FRAME OVER COVER	1	
45	0019208020	HEX HEAD BOLT	37	
46	M3310600004	COVER	1	
47	0019208020	HEX HEAD BOLT	4	
48	M3453201602	SPLASHER PANEL	1	
48A	M3493426404	ACOUSTIC SHEET	1	
49	0019108055	HEX HEAD BOLT	4	
49A	0042308000	WASHER, LOCK	4	
49B	0042408000	WASHER, FLAT	4	
50	0016910025	HEX HEAD BOLT	2	
51	M3453004903	SIDE DOOR	1	
51A	M3493425703	ACOUSTIC SHEET	1	
52	M3453005003	SIDE DOOR	1	
52A	M3493425903	ACOUSTIC SHET	1	
53	M3453005103	SIDE DOOR	1	
53A	M3493426104	ACOUSTIC SHEET	1	
54	M3453005203	SIDE DOOR	1	
54A	M3493426203	ACOUSTIC SHEET	1	
55	M3453303103	DUCT	2	
55A	M3493425804	ACOUSTIC SHEET	2	
56	M3453303203	DUCT	1	
56A	M3493426004	ACOUSTIC SHEET	1	
57	M3453302903	DUCT	1	
57A	M3493423904	ACOUSTIC SHEET	1	
58	M3453303303	DUCT	1	
58A	M3493426304	ACOUSTIC SHEET	1	
59	0207006000	HEX NUT	27	
60	M9113000002	DOOR HANDLE ASSY	4	
61	0021806016	MACHINE SCREW	16	
61A	0030006000	HEX NUT	16	

ENCLOSURE ASSY. (CONTINUED)

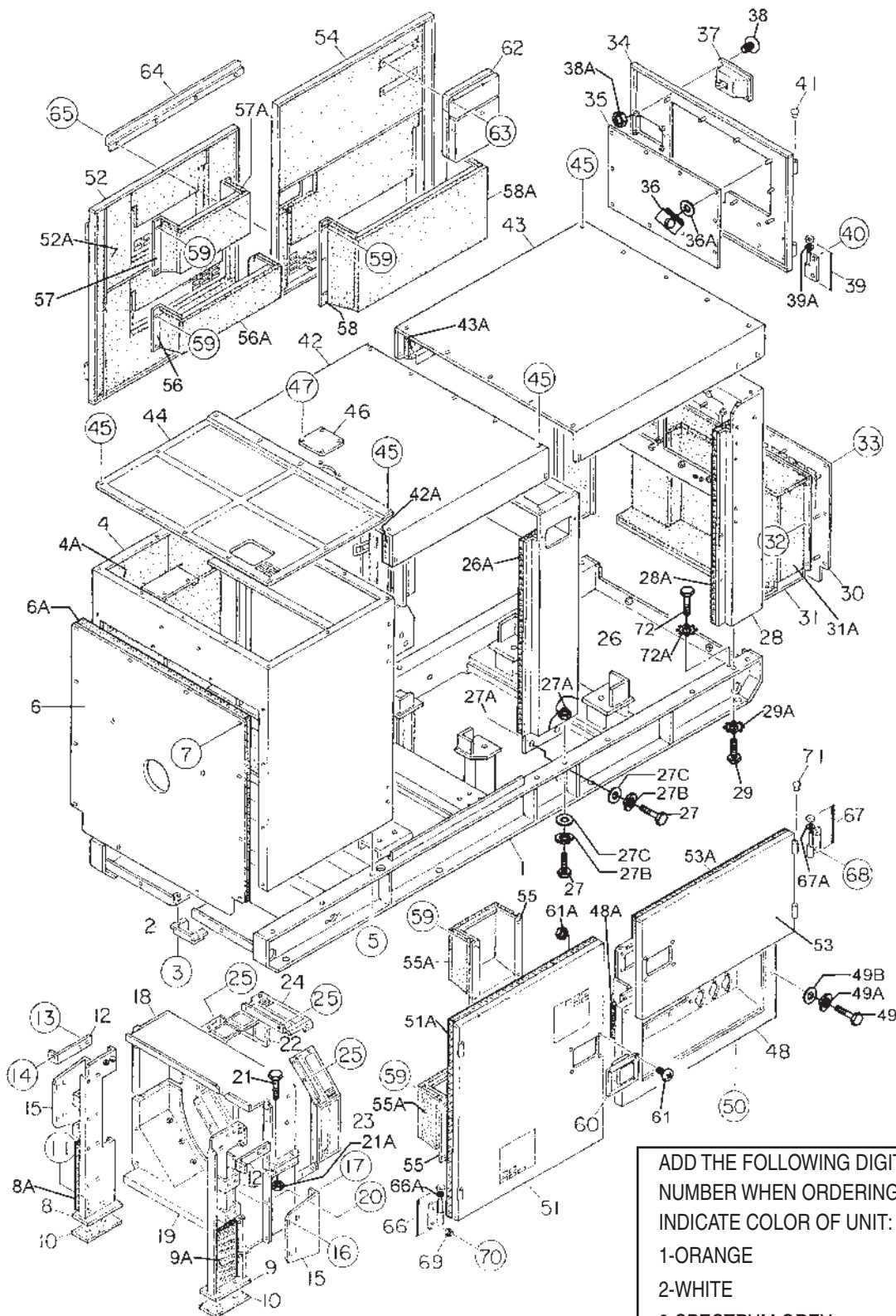

ADD THE FOLLOWING DIGITS AFTER THE PART NUMBER WHEN ORDERING ANY PAINTED PANEL TO INDICATE COLOR OF UNIT:

1-ORANGE	5-BLACK
2-WHITE	6-CATERPILLAR YELLOW
3-SPECTRUM GREY	7-CATO GOLD
4-SUNBELT GREEN	8-RED

THE SERIAL NUMBER MAY BE REQUIRED.

ENCLOSURE ASSY. (CONTINUED)

<u>NO.</u>	<u>PART NO.</u>	<u>PART NAME</u>	<u>QTY.</u>	<u>REMARKS</u>
62	0600800320	MANUAL PAK	1	
63	0021806016	MACHINE SCREW	4	
64	M3453700004	GUTTER	1	
65	0019206015	HEX HEAD BOLT	4	
66	M9110100204	HINGE	4	
66A	M9116100004	WASHER	4	
67	M9110100304	HINGE	4	
67A	M9116100004	WASHER	4	
68	0019208020	HEX HEAD BOLT	9	
69	0601850097	STOPPER	8	
70	0027208025	MACHINE SCREW	8	
71	M9310000004	BLIND PLUG	8	
72	0016908020	HEX HEAD BOLT	1	
72A	0040508000	TOOTHED WASHER	1	

RUBBER SEALS ASSY.

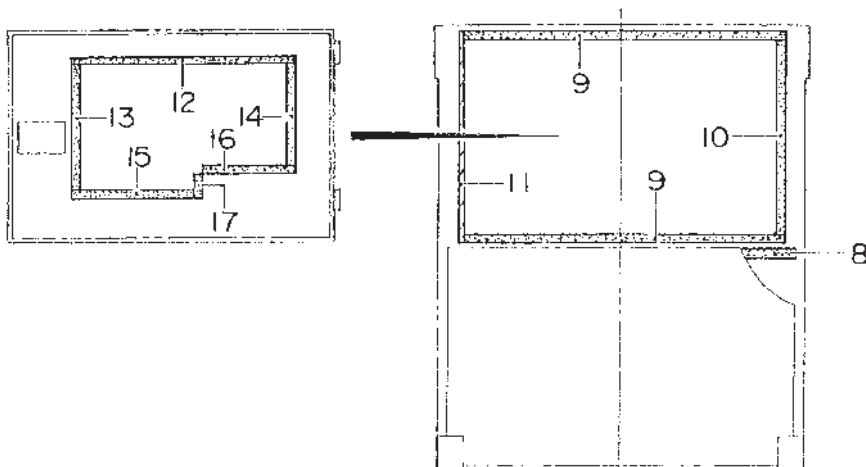
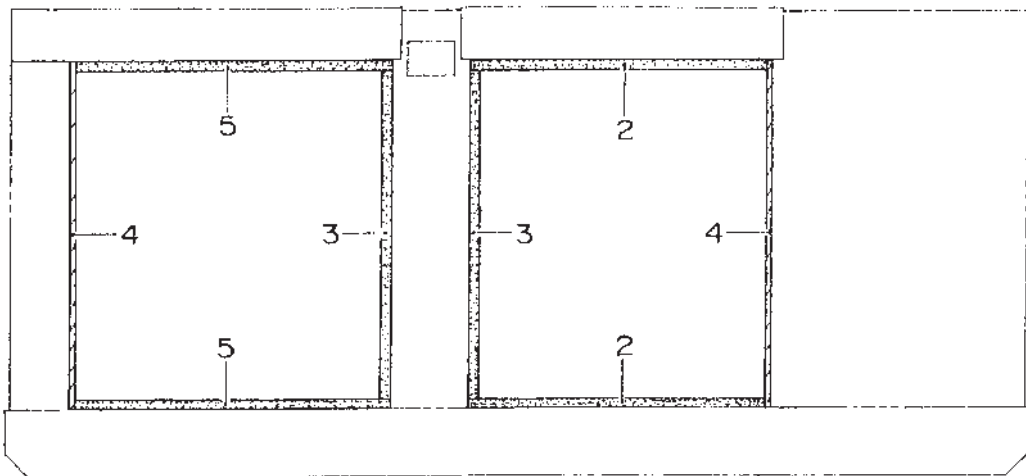
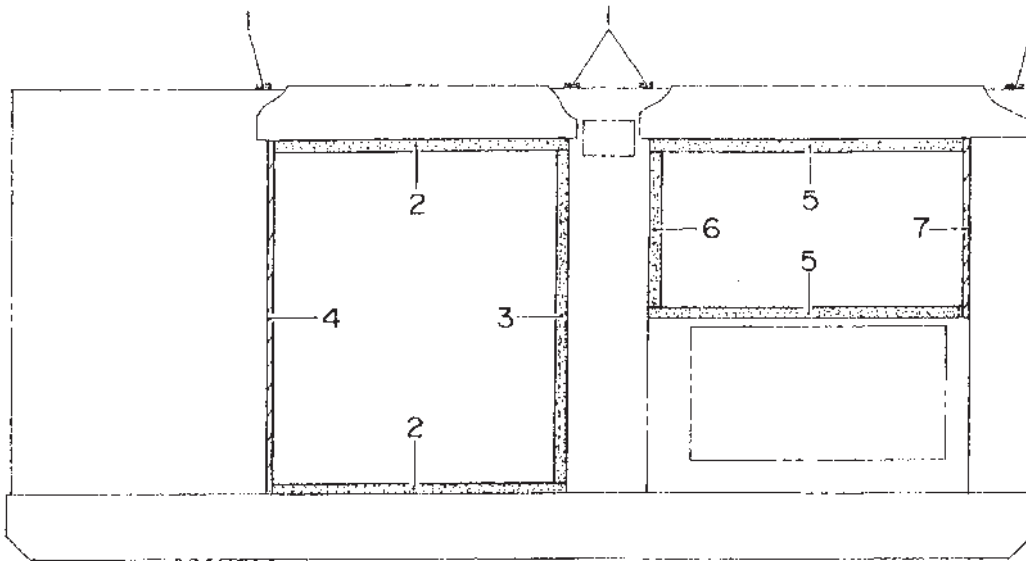

RUBBER SEALS ASSY.

<u>NO.</u>	<u>PART NO.</u>	<u>PART NAME</u>	<u>QTY.</u>	<u>REMARKS</u>
1	0229201100	RUBBER SEAL	4	
2	0228900880	RUBBER SEAL	4	
3	0228900990	RUBBER SEAL	3	
4	0228901050	RUBBER SEAL	3	
5	0228900904	RUBBER SEAL	4	
6	0228900470	RUBBER SEAL	1	
7	0228900530	RUBBER SEAL	1	
8	0229201040	RUBBER SEAL	1	
9	0228800970	RUBBER SEAL	2	
10	0228800590	RUBBER SEAL	1	
11	0228800630	RUBBER SEAL	1	
12	0228100665	RUBBER SEAL	1	
13	0228100370	RUBBER SEAL	1	
14	0228100300	RUBBER SEAL	1	
15	0228100365	RUBBER SEAL	1	
16	0228100280	RUBBER SEAL	1	
17	0228100070	RUBBER SEAL	1	

NAMEPLATE AND DECALS ASSY.

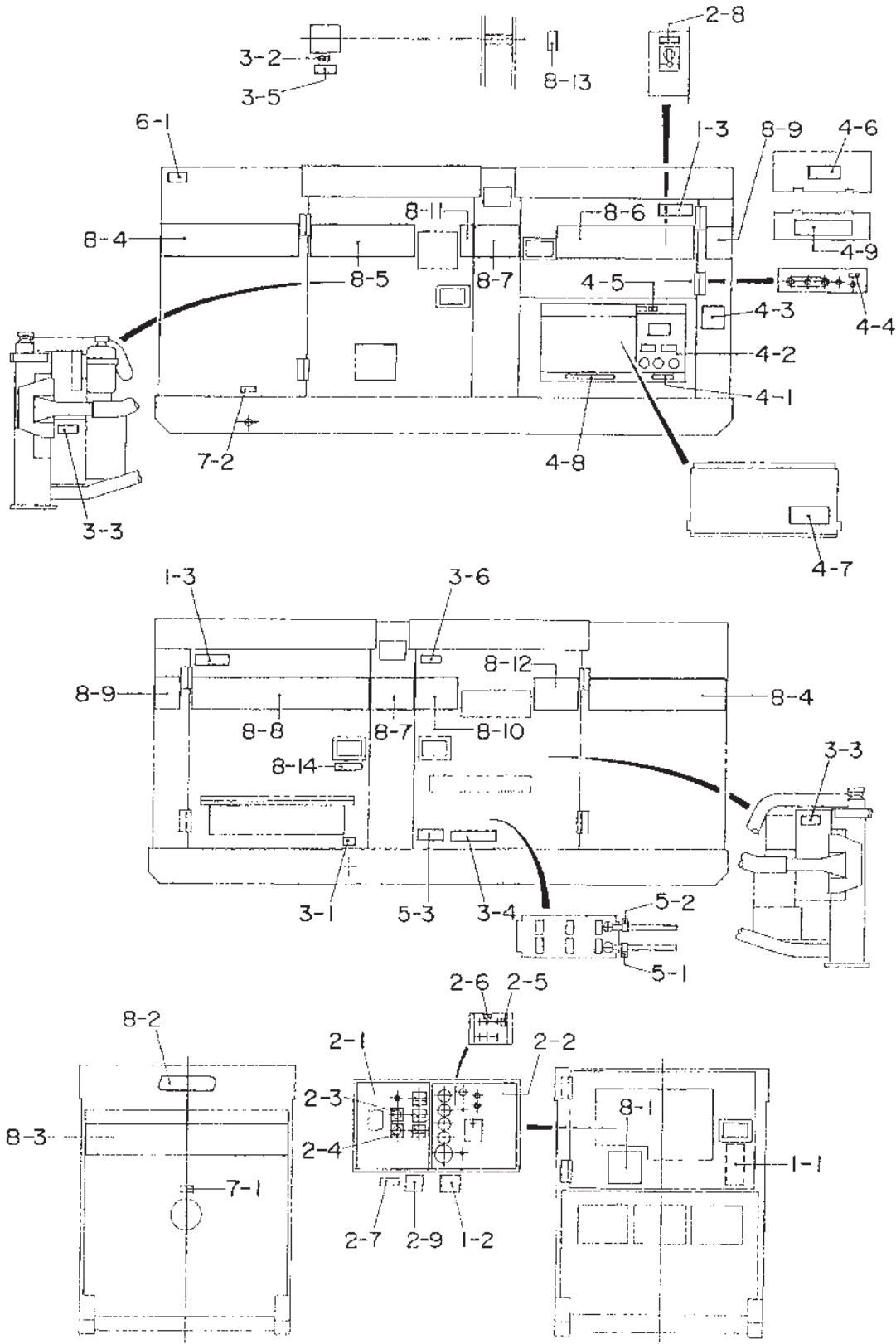

NAMEPLATE AND DECALS ASSY.

<u>NO.</u>	<u>PART NO.</u>	<u>PART NAME</u>	<u>QTY.</u>	<u>REMARKS</u>
1-1	M3550003003	DECAL : OPERATING PROCEDURES	1	M35000300A
1-2	M9520100304	DECAL : SAFETY INSTRUCTIONS	1	M92010030
1-3	M9520100603	DECAL : CAUTION	2	M92010060
CONTROL BOX GROUP				
2-1	M3550003303	DECAL : CONTROL PANEL	1	M35000330
2-2	M3550003403	DECAL : OPERATING PANEL	1	M35000340
2-3	M9520000104	PLATE : AMMETER CHANGE- OVER SWITCH	1	M92000010
2-4	M9520000204	PLATE : VOLTMETER CHANGE- OVER SWITCH	1	M92000020
2-5	M9520000904	DECAL : DIAGNOSTIC SWITCH	1	M92000090
2-6	M9520001104	DECAL : DIAGNOSTIC BUTTON	1	M92000110
2-7	M9520100004	DECAL : WARNING ELECTRIC SHOCK HAZARD	1	M92010000
2-8	M9520100204	DECAL : CAUTION	1	M92010020A
2-9	M9520200404	DECAL : OVER CURRENT RELAY	1	M92020040
ENGINE & RADIATOR GROUP				
3-1	M9500000004	DECAL : OIL DRAIN PLUG	1	M90000000
3-2	M9500100004	DECAL : WATER	1	M90010000
3-3	M9503000004	DECAL : WARNING MOVING PARTS	2	M90300000
3-4	M9503000103	DECAL : WATER - OIL CHECK	1	M90300010
3-5	M9503100004	DECAL : WARNING HOT COOLANT	1	M90310000
3-6	M9510100004	DECAL : CAUTION HOT PARTS	1	M91010000
OUTPUT TERMINAL GROUP				
4-1	M1550000204	DECAL : NOTE	1	M15000020
4-2	M1550002203	DECAL : RECEPTACLE & CIRCUIT BREAKER	1	M15000220
4-3	M3550000004	DECAL : NOTE	1	M35000000
4-4	M9520000004	DECAL : GROUND	1	M92000000
4-5	M9520000504	DECAL : START CONTACT	1	M92000050
4-6	M9520100004	DECAL : WARNING ELECTRIC SHOCK HAZARD	1	M92010000
4-7	M9520100404	DECAL : DANGER HIGH VOLTAGE	1	M92010040
4-8	M9520100503	DECAL : WARNING	1	M92010050
4-9	M9520200003	DECAL : OUTPUT TERMINAL	1	M92020000
BATTERY GROUP				
5-1	M9500300004	DECAL : -	1	M90030000
5-2	M9500300104	DECAL : +	1	M90030010
5-3	M9510100403	DECAL : CAUTION	1	M91010040
MUFFLER GROUP				
6-1	M9503200004	DECAL : WARNING ENGINE EXHAUST	1	M90320000

NAMEPLATE AND DECALS ASSY. (CONTINUED)

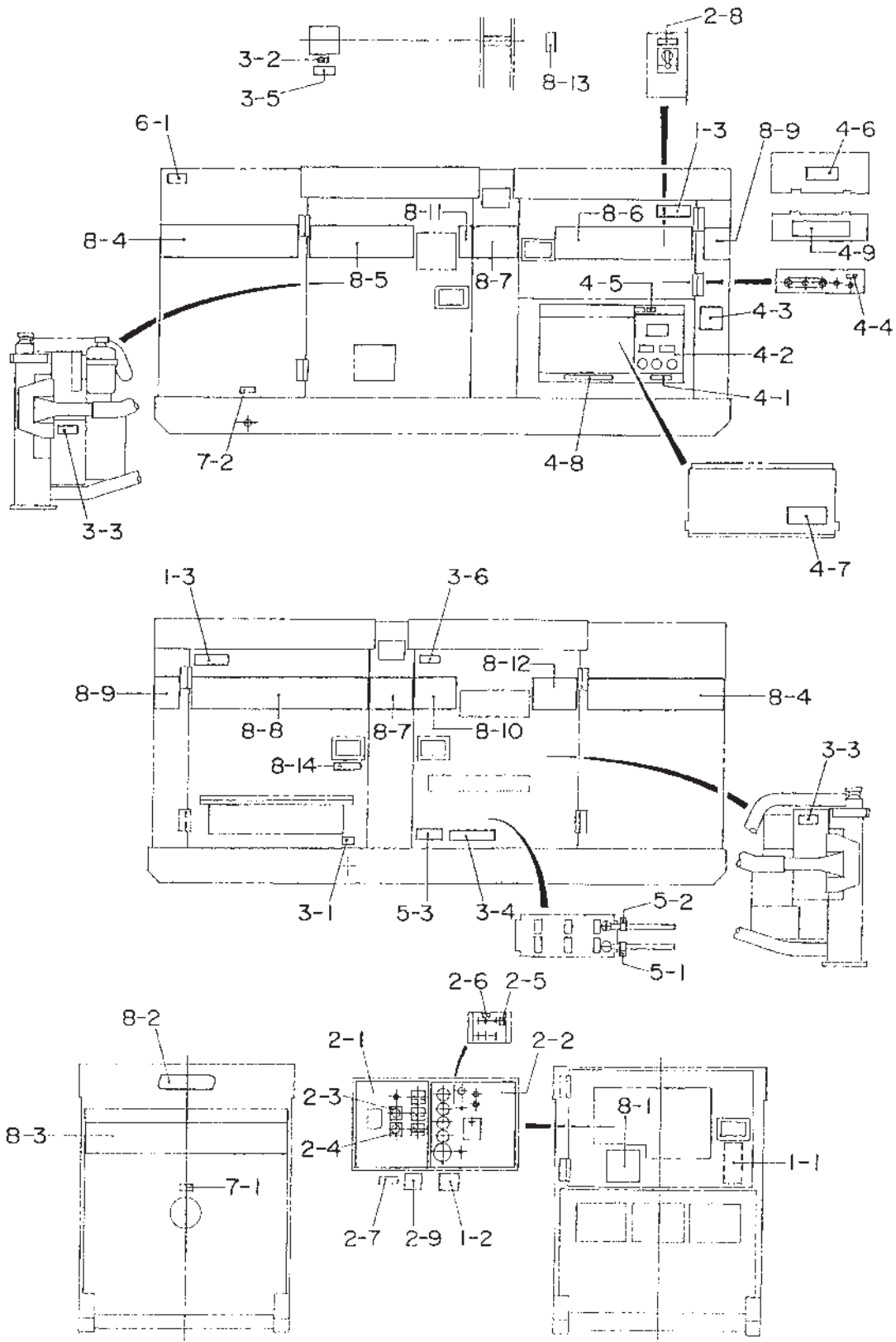

NAMEPLATE AND DECALS ASSY. (CONTINUED)

<u>NO.</u>	<u>PART NO.</u>	<u>PART NAME</u>	<u>QTY.</u>	<u>REMARKS</u>
		FUEL TANK GROUP		
7-1	M9500500004	DECAL : DIESEL FUEL.....	1	M90050000
7-2	M9500500104	DECAL : FUEL DRAIN PLUG	1	M90050010
		ENCLOSURE GROUP		
8-1	M9510200002	DECAL : MQ.....	1	M91020000
8-2	060050090	EMBLEM	1	
8-2A	0021106016	MACHINE SCREW	2	
8-3	M3560100003	STRIPE	1	
8-4	M3560100103	STRIPE	2	
8-5	M3560103804	STRIPE	1	
8-6	M3560100303	STRIPE	1	
8-7	M3560100404	STRIPE	2	
8-8	M3560100503	STRIPE	1	
8-9	M3560100604	STRIPE	2	
8-10	M3560103504	STRIPE	1	
8-11	M3560103604	STRIPE	1	
8-12	M3560103704	STRIPE	1	
8-13	M3550002204	DECAL : CAUTION.....	1	M35000220
8-14	M9510000104	DECAL : DOCUMENT BOX LOCATED.....	1	M91000010

TERMS AND CONDITIONS OF SALE — PARTS

PAYMENT TERMS

Terms of payment for parts are net 30 days.

FREIGHT POLICY

All parts orders will be shipped collect or prepaid with the charges added to the invoice. All shipments are F.O.B. point of origin. Multiquip's responsibility ceases when a signed manifest has been obtained from the carrier, and any claim for shortage or damage must be settled between the consignee and the carrier.

MINIMUM ORDER

The minimum charge for orders from Multiquip is \$15.00 net. Customers will be asked for instructions regarding handling of orders not meeting this requirement.

RETURNED GOODS POLICY

Return shipments will be accepted and credit will be allowed, subject to the following provisions:

1. A Returned Material Authorization must be approved by Multiquip prior to shipment.
2. To obtain a Return Material Authorization, a list must be provided to Multiquip Parts Sales that defines item numbers, quantities, and descriptions of the items to be returned.
 - a. The parts numbers and descriptions must match the current parts price list.
 - b. The list must be typed or computer generated.
 - c. The list must state the reason(s) for the return.
 - d. The list must reference the sales order(s) or invoice(s) under which the items were originally purchased.
 - e. The list must include the name and phone number of the person requesting the RMA.
3. A copy of the Return Material Authorization must accompany the return shipment.
4. Freight is at the sender's expense. All parts must be returned freight prepaid to Multiquip's designated receiving point.

5. Parts must be in new and resalable condition, in the original Multiquip package (if any), and with Multiquip part numbers clearly marked.
6. The following items are not returnable:
 - a. Obsolete parts. (If an item is in the price book and shows as being replaced by another item, it is obsolete.)
 - b. Any parts with a limited shelf life (such as gaskets, seals, "O" rings, and other rubber parts) that were purchased more than six months prior to the return date.
 - c. Any line item with an extended dealer net price of less than \$5.00.
 - d. Special order items.
 - e. Electrical components.
 - f. Paint, chemicals, and lubricants.
 - g. Decals and paper products.
 - h. Items purchased in kits.
7. The sender will be notified of any material received that is not acceptable.
8. Such material will be held for five working days from notification, pending instructions. If a reply is not received within five days, the material will be returned to the sender at his expense.
9. Credit on returned parts will be issued at dealer net price at time of the original purchase, less a 15% restocking charge.
10. In cases where an item is accepted, for which the original purchase document can not be determined, the price will be based on the list price that was effective twelve months prior to the RMA date.
11. Credit issued will be applied to future purchases only.

PRICING AND REBATES

Prices are subject to change without prior notice. Price changes are effective on a specific date and all orders received on or after that date will be billed at the revised price. Rebates for price declines and added charges for price increases will not be made for stock on hand at the time of any price change.

Multiquip reserves the right to quote and sell direct to Government agencies, and to Original Equipment Manufacturer accounts who use our products as integral parts of their own products.

SPECIAL EXPEDITING SERVICE

A \$35.00 surcharge will be added to the invoice for special handling including bus shipments, insured parcel post or in cases where Multiquip must personally deliver the parts to the carrier.

LIMITATIONS OF SELLER'S LIABILITY

Multiquip shall not be liable hereunder for damages in excess of the purchase price of the item with respect to which damages are claimed, and in no event shall Multiquip be liable for loss of profit or good will or for any other special, consequential or incidental damages.

LIMITATION OF WARRANTIES

No warranties, express or implied, are made in connection with the sale of parts or trade accessories nor as to any engine not manufactured by Multiquip. Such warranties made in connection with the sale of new, complete units are made exclusively by a statement of warranty packaged with such units, and Multiquip neither assumes nor authorizes any person to assume for it any other obligation or liability whatever in connection with the sale of its products. Apart from such written statement of warranty, there are no warranties, express, implied or statutory, which extend beyond the description of the products on the face hereof.

Effective: February 22, 2006

OPERATION AND PARTS MANUAL

HERE'S HOW TO GET HELP

PLEASE HAVE THE MODEL AND SERIAL
NUMBER ON-HAND WHEN CALLING

UNITED STATES

Multiquip Corporate Office

18910 Wilmington Ave.
Carson, CA 90746
Contact: mq@multiquip.com

Tel. (800) 421-1244
Fax (800) 537-3927

Service Department

800-421-1244
310-537-3700

Fax: 310-537-4259

Technical Assistance

800-478-1244

Fax: 310-943-2238

MQ Parts Department

800-427-1244
310-537-3700

Fax: 800-672-7877
Fax: 310-637-3284

Warranty Department

800-421-1244
310-537-3700

Fax: 310-943-2249

MEXICO

MQ Cipsa

Carr. Fed. Mexico-Puebla KM 126.5
Momoxpan, Cholula, Puebla 72760 Mexico
Contact: pmastretta@cipsa.com.mx

Tel: (52) 222-225-9900
Fax: (52) 222-285-0420

CANADA

Multiquip

4110 Industriel Boul.
Laval, Quebec, Canada H7L 6V3
Contact: jmartin@multiquip.com

Tel: (450) 625-2244
Tel: (877) 963-4411
Fax: (450) 625-8664

UNITED KINGDOM

Multiquip (UK) Limited Head Office

Unit 2, Northpoint Industrial Estate,
Globe Lane,
Dukinfield, Cheshire SK16 4UJ
Contact: sales@multiquip.co.uk

Tel: 0161 339 2223
Fax: 0161 339 3226

© COPYRIGHT 2011, MULTIQUIP INC.

Multiquip Inc, the MQ logo and the MQ Power logo are registered trademarks of Multiquip Inc. and may not be used, reproduced, or altered without written permission. All other trademarks are the property of their respective owners and used with permission.

This manual MUST accompany the equipment at all times. This manual is considered a permanent part of the equipment and should remain with the unit if resold.

The information and specifications included in this publication were in effect at the time of approval for printing. Illustrations, descriptions, references and technical data contained in this manual are for guidance only and may not be considered as binding. Multiquip Inc. reserves the right to discontinue or change specifications, design or the information published in this publication at any time without notice and without incurring any obligations.

Your Local Dealer is:





Turnkey Industries is an expert in the field of purchasing and selling pre-owned industrial generators. We offer many different brands, sizes, and capacities of generators. We fulfill orders across the country and beyond, and our elaborate preparatory processes ensure that our equipment is ready for immediate usage on arrival.

[See All Inventory](#)



**Immediate
Availability**



**Worldwide
Delivery**



**Low Hour
Generator Sets**

Contact Us



sales@turnkey-industries.com



713-823-0890



Turnkey Industries, LLC
P.O. Box 3876 Humble, TX 77347

