

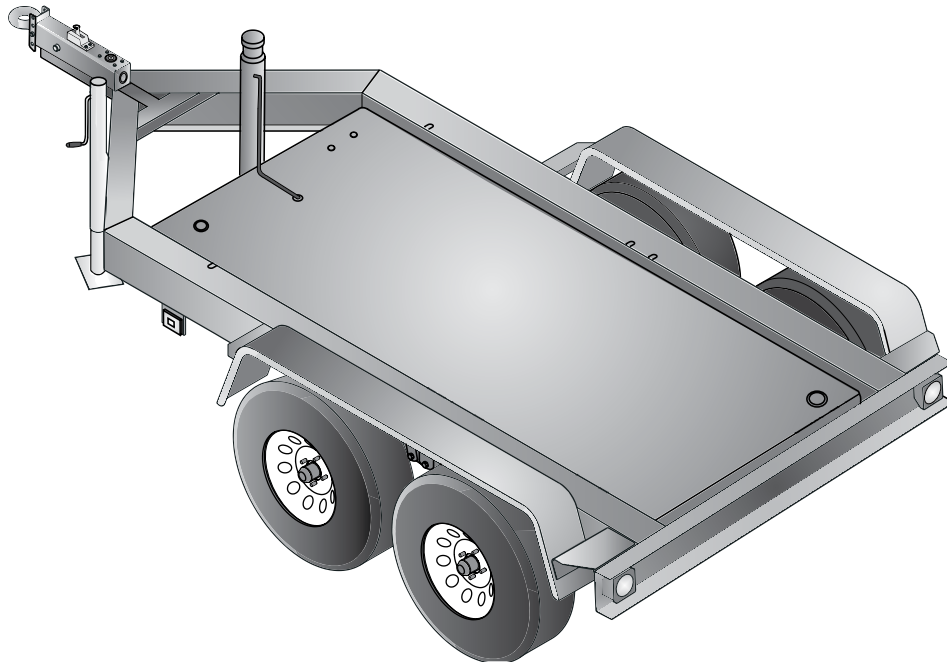

# TRLR70XF

## MQ POWER Tandem Axle Trailer



### TRLR70XF Technical Data

Gross Vehicle Weight Rating (GVWR) — 6,000 lbs (2,722 kg)	Tire Size — ST205/75D14 LR-C
Gross Axle Weight Rating (GAWR) — 3,500 lbs (1,588 kg) (ea.)	Wheel Bolt Pattern — 5 Lug on 4.5 in
Hydraulic Actuator Rating — 7,500 lbs (3,402 kg)	Tire Load Rating — 1,760 lbs/798 kg (ea.)
Coupler Rating — See coupler options on back page.	Dimensions (LxWxH) — See back page

### STANDARD TRAILER EQUIPMENT

- Fits MQ Power Generator Models DCA36SPX, DCA45SS, DCA70SSI
- Tandem-axle Design with Spring Type Suspension
- H.D. Welded Steel Frame Construction
- Formed Channel for Generator Mounting and Support
- Integral Fuel Cell; Single-wall Steel Design, 52 Gallon Capacity
- Replaceable, Bolt-on Hydraulic Brake Actuator
- Surge Hydraulic-actuated Drum Brakes (all axles)
- Hydraulic Uni-servo Drum Brakes - 10-inch Cluster (allows 15-20% braking in reverse)
- D.O.T. Steel Brake Lines, Brass Tees & Rubber Hydraulic Brake Hoses
- 4-hole Channel Allows 3-position, Adjustable Coupler Height; 4-inches O/A
- Tongue Mounted Swivel Jack with Flat Disc-foot (rated 2,000 pound lift)
- Replaceable, Bolt-on Steel Fenders
- Powder Coat Paint Process including: Frame, Channel, Actuator & Fenders
- D.O.T. Approved Tail Lamps, Stop Lamps, Turn Signal Lamps, Side Marker Lamps



# TRLR70XF

## MQ POWER Tandem Axle Trailer

### OPTIONAL TRAILER EQUIPMENT

- Electric Drum Brakes (all axles)
- Electric Breakaway Safety Device (electric-actuated brakes)
- Adjustable 2-inch Ball Coupler
- Adjustable 2 5/16-inch Ball Coupler
- Adjustable 3-inch Pintle-eye Coupler
- Rear Stabilizer Stands
- Tongue Mounted Utility Storage Box
- Anti-Theft Wheel Lock
- Spare Tire with Locking Mount

### Coupler Options

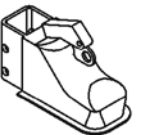
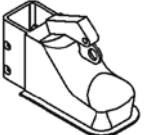
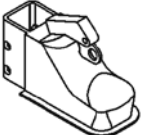
3" Pintle Eye 20,000 lbs. (9,072 kg) #EE36264	
2" Ball Coupler 6,000 lbs. (2,722 kg) #29228	
10,000 lbs. (4,536 kg) #EE43254	
2-5/16" Ball Coupler 14,000 lbs. (6,350 kg) #EE43253	

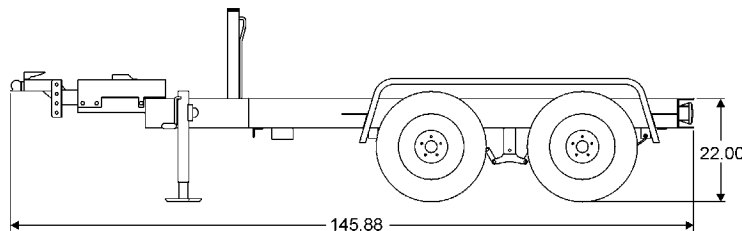
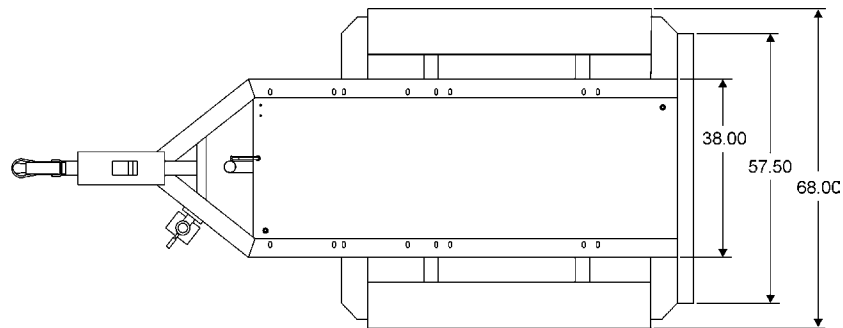

Trailer Weight	
Without fuel	With fuel
765 lbs. (347 kg)	1,134 lbs. (515 kg)

Your Multiquip dealer is:

