

# OPERATION AND PARTS MANUAL

## MQ POWER DCA-70SSJU WHISPERWATT™ GENERATOR

S/N 7300000-2140 KEY START  
S/N 7302141-3869 ECU/EGS

© COPYRIGHT 2003, MULTQUIP INC.

PARTS LIST NO. M1870300034A

Revision #5 (06/03/03)



**MULTQUIP INC.**

18910 WILMINGTON AVE.  
CARSON, CALIFORNIA 90746  
310-537-3700  
800-421-1244  
FAX: 310-537-3927  
E-mail: [mq@multiquip.com](mailto:mq@multiquip.com)

**PARTS DEPARTMENT:**

800-427-1244  
FAX: 800-672-7877

**SERVICE DEPARTMENT:**

800-835-2551  
FAX: 310-638-8046

• [www.multiquip.com](http://www.multiquip.com)



# **WARNING**



## **CALIFORNIA — Proposition 65 Warning**

**Diesel engine exhaust and some of its constituents are known to the State of California to cause cancer, birth defects and other reproductive harm.**

## **HERE'S HOW TO GET HELP**

*PLEASE HAVE THE MODEL AND SERIAL  
NUMBER ON-HAND WHEN CALLING*

### ***PARTS DEPARTMENT***

*800-427-1244 or 310-537-3700*

*FAX: 800-672-7877 or 310-637-3284*

### ***SERVICE DEPARTMENT***

*800-421-1244*

*FAX: 310- 537-4259*

### ***TECHNICAL ASSISTANCE***

*800-478-1244*

*FAX: 310- 631-5032*

### ***WARRANTY DEPARTMENT***

*888-661-4279, or 310-661-4279*

*FAX: 310- 537-1173*

**MQ POWER DCA70SSJU  
AC GENERATOR**

Here's How To Get Help ..... 3  
 Table Of Contents ..... 4  
 Parts Ordering Procedures ..... 5  
 Specifications ..... 6  
 Dimensions (Top, Side, Front) ..... 7  
 Safety Message Alert Symbols ..... 8-9  
 Rules for Safe Operation ..... 10-13  
 Installation ..... 14-15  
 Towing Safety Precaution ..... 16  
 Trailer Specifications ..... 17-19  
 Generator Decals ..... 20-21  
 General Information ..... 22  
 Major Components ..... 23  
 Generator Control Panel ..... 24  
 Engine Operating Panel (up to S/N 73002140) ..... 25  
 Engine Operating Panel (S/N 73002140~) ..... 26-27  
 Output Terminal Panel Familiarization ..... 28-30  
 Load Application ..... 31  
 Generator Outputs ..... 32-33  
 Gauge Reading ..... 33  
 Output Terminal Panel Connections ..... 34-35  
 Pre Setup ..... 36-40  
 Generator Start-up Procedure (Manual) ..... 41-44  
 Generator Start-up Procedure (Auto Mode) ..... 45  
 Generator Shut-Down Procedure ..... 46  
 Maintenance ..... 47-49  
 Trailer Brakes Maintenance ..... 50  
 Trailer Maintenance ..... 51-52  
 Trailer Wiring Diagram ..... 53  
 Generator Wiring Diagram ..... 54  
 Engine Wiring Diagram (w/ Controller) ..... 55  
 Engine Wiring Diagram (Ignition Switch) ..... 56  
 Engine Troubleshooting ..... 57-58  
 Generator Troubleshooting ..... 59  
 Engine Controller Troubleshooting ..... 60  
 Explanation of Code in Remarks Column ..... 62  
 Suggested Spare Parts ..... 63

**COMPONENT DRAWINGS**

Name Plate And Decals ..... 64-65  
 Generator Assembly ..... 66-69  
 Control Box Assembly ..... 70-75  
 Engine & Radiator Assembly ..... 76-79  
 Engine Operating Panel Assembly ..... 80-83  
 Output Terminal Assembly ..... 84-85  
 Battery Assembly ..... 86-87  
 Muffler Assembly ..... 88-89  
 Fuel Tank Assembly ..... 90-95  
 Enclosure Assembly ..... 96-97  
 Rubber Seal Assembly ..... 98-99  
 Terms and Condition of Sale — Parts ..... 100

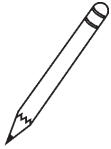
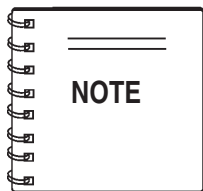

*Specification and part number are subject to change without notice.*

# PARTS ORDERING PROCEDURES

## When ordering parts, please supply the following information:

- Dealer account number
- Dealer name and address
- Shipping address (if different than billing address)
- Return fax number
- Applicable model number
- Quantity, part number and description of each part
- Specify preferred method of shipment:
  - ✓ FedEx or UPS Ground
  - ✓ FedEx or UPS Second Day or Third Day
  - ✓ FedEx or UPS Next Day
  - ✓ Federal Express Priority One
  - ✓ DHL
  - ✓ Truck

*Note: Unless otherwise indicated by customer, all orders are treated as "Standard Orders", and will ship within 24 hours. We will make every effort to ship "Air Shipments" the same day that the order is received, if prior to 2PM west coast time. "Stock Orders" must be so noted on fax or web forms.*



## Here's how to get help...

*Please have the model and serial number on hand when calling.*

### Parts Department

800-427-1244 Fax: 800-672-7877  
310-537-3700 Fax: 310-637-3284

### Mayco Parts

800-306-2926 Fax: 800-672-7877  
310-537-3700 Fax: 310-637-3284

### Service Department

800-478-1244 Fax: 310-537-4259  
310-537-3700

### MQ Power Service Department

800-835-2551 Fax: 310-638-8046  
310-537-3700

### Warranty Department

800-421-1244, Ext. 279 Fax: 310-537-1173  
310-537-3700, Ext. 279

### Multiquip's Main Phone Numbers

800-421-1244 Fax: 310-537-3927  
310-537-3700

## Place Your Parts Order Via Web or Fax For Even More Savings!

### Extra Discounts!

All parts orders which include complete part numbers and are received by our automated web parts order system, or by fax qualify for the following extra discounts:

Ordered via	Standard orders	Stock orders (\$750 list and above)
Fax	3%	10%
Web	5%	10%

### Special freight allowances when you order 10 or more line items via Web or Fax! \*\*

FedEx Ground Service **at no charge for freight**  
No other allowances on freight shipped by any other carrier.

NOTE: DISCOUNTS ARE SUBJECT TO CHANGE



**MULTIQUIP INC.**  
18910 WILMINGTON AVENUE  
POST OFFICE BOX 6254  
CARSON, CALIFORNIA 90749  
310-537-3700 • 800-421-1244  
FAX: 310-537-3927  
E-MAIL: mq@multiquip.com  
WWW: multiquip.com

**Direct TOLL-FREE access  
to our Parts Department:**

Toll-free nationwide — 800-427-1244

# DCA-70SSJU SERIES — SPECIFICATIONS

<b>Table 1. Generator Specifications</b>		
<b>Model</b>	<b>DCA-70SSJU</b>	
<b>Type</b>	Revolving field, self ventilated, open protected type synchronous generator	
<b>Armature Connection</b>	<b>Star with Neutral</b>	<b>Zig Zag</b>
<b>Phase</b>	3	Single
<b>Standby Output</b>	77 KVA (61.6 KW)	44 KW
<b>Prime Output</b>	70 KVA (56 KW)	40KW
<b>Voltage</b>	240V or 480V	240/120V
<b>Frequency</b>	60 Hz	
<b>Speed</b>	1800 rpm	
<b>Power Factor</b>	0.8	1
<b>Aux. AC Power</b>	Single Phase, 60 Hz	
<b>Voltage</b>	120 V	
<b>Output</b>	4.8 KW (2.4 KW x 2)	
<b>Engine Specifications</b>		
<b>Model</b>	JOHN DEERE 4045TF 150	
<b>Type</b>	4 Cycle, water-cooled, direct injection, turbo-charged	
<b>No. of Cylinders</b>	4 cylinders	
<b>Bore x Stroke</b>	4.19 in. x 5 in. (106 mm x 127 mm)	
<b>Rated Output</b>	90HP/1800 rpm	
<b>Displacement</b>	274 cu. in. (4500 cc)	
<b>Starting</b>	Electric	
<b>Coolant Capacity</b>	6.9 gal. (26 liters)	
<b>Lube Oil Capacity</b>	3.4 gal. (13 liters)	
<b>Fuel Consumption</b>	4.7 gal. (17.9L)/hr at <b>full load</b>	3.5 gal. (13.3L)/hr at <b>3/4 load</b>
	2.6 gal. (9.9L)/hr at <b>1/2 load</b>	1.6 gal. (6.1L)/hr at <b>1/4 load</b>
<b>Battery</b>	12V- 120AH	
<b>Fuel</b>	#2 Diesel Fuel	

# DCA-70SSJU SERIES — DIMENSIONS (TOP, SIDE AND FRONT)

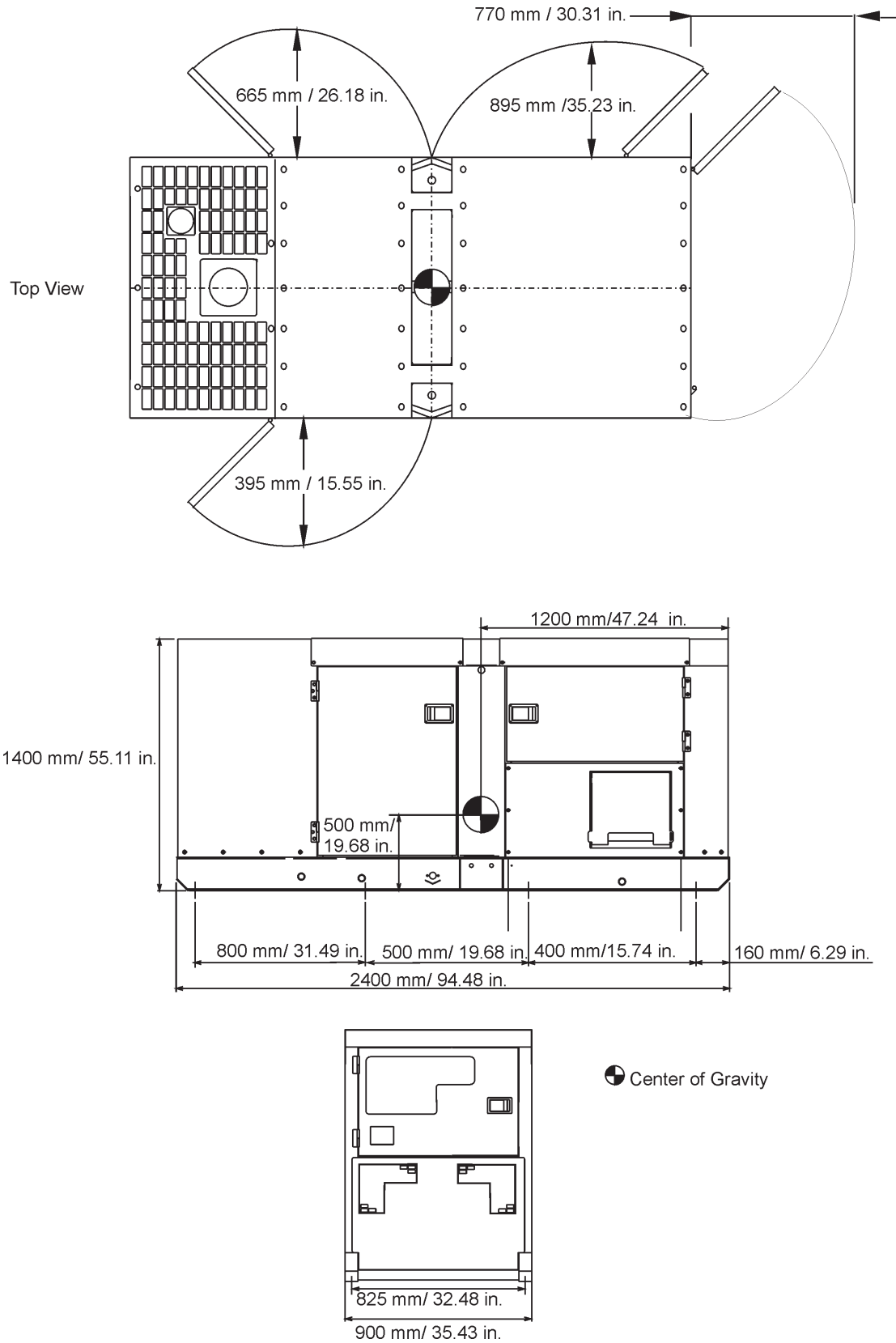
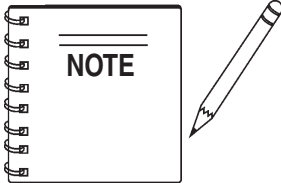

**Figure 1. Dimensions**

# DCA70SSJU — SAFETY MESSAGE ALERT SYMBOLS

## FOR YOUR SAFETY AND THE SAFETY OF OTHERS!

Safety precautions should be followed at all times when operating this equipment. Failure to read and understand the Safety Messages and Operating Instructions could result in injury to yourself and others.



This Owner's Manual has been developed to provide complete instructions for the safe and efficient operation of the MQ Power Model **DCA70SSJU Series WHISPERWATT™ GENERATOR**.

**Before using this GENERATOR, ensure that the operating individual has read and understands all instructions in this manual.**

## SAFETY MESSAGE ALERT SYMBOLS

The three (3) Safety Messages shown below will inform you about potential hazards that could injure you or others. The Safety Messages specifically address the level of exposure to the operator, and are preceded by one of three words: **DANGER**, **WARNING**, or **CAUTION**.



**DANGER:** You **WILL** be **KILLED** or **SERIOUSLY** injured if you **DO NOT** follow directions.



**WARNING:** You **CAN** be **KILLED** or **SERIOUSLY** injured if you **DO NOT** follow directions.



**CAUTION:** You **CAN** be injured if you **DO NOT** follow directions.

Potential hazards associated with trowel operation will be referenced with "**Hazard Symbols**" which appear throughout this manual, and will be referenced in conjunction with Safety "**Message Alert Symbols**".

## HAZARD SYMBOLS



### Lethal Exhaust Gases



Engine exhaust gases contain poisonous carbon monoxide. This gas is colorless and odorless, and can cause death if inhaled. **NEVER** operate this equipment in a confined area or enclosed structure that does not provide ample free flow air.



### Explosive Fuel



Diesel fuel is extremely flammable, and its vapors can cause an explosion if ignited. **DO NOT** start the engine near spilled fuel or combustible fluids. **DO NOT** fill the fuel tank while the engine is running or hot. **DO NOT** overfill tank, since spilled fuel could ignite if it comes into contact with hot engine parts or sparks from the ignition system. Store fuel in approved containers, in well-ventilated areas and away from sparks and flames. **NEVER** use fuel as a cleaning agent.



### Burn Hazards



Engine components can generate extreme heat. To prevent burns, **DO NOT** touch these areas while the engine is running or immediately after operations. **NEVER** operate the engine with heat shields or heat guards removed.



### Rotating Parts



**NEVER** operate equipment with covers, or guards removed. Keep **fingers, hands, hair** and **clothing** away from all moving parts to prevent injury.



# DCA70SSJU — SAFETY MESSAGE ALERT SYMBOLS



## Accidental Starting



OFF

**ALWAYS** place the engine ON/OFF switch in the **OFF** position, when the trowel is not in use.



## Respiratory Hazard



**ALWAYS** wear approved respiratory protection.



## Over Speed Conditions



**NEVER** tamper with the factory settings of the engine governor or settings. Personal injury and damage to the engine or equipment can result if operating in speed ranges above maximum allowable.



## Sight and Hearing hazard

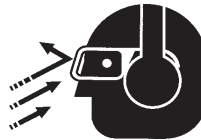

**ALWAYS** wear approved eye and hearing protection.

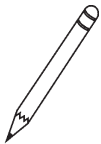
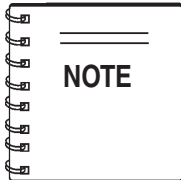

This **generator**, other property, or the surrounding environment could be damaged if you do not follow instructions.



## Equipment Damage Messages

Other important messages are provided throughout this manual to help prevent damage to your trowel, other property, or the surrounding environment.

# DCA-70SSJU SERIES — RULES FOR SAFE OPERATION

## CAUTION:



Failure to follow instructions in this manual may lead to serious injury or even death! This equipment is to be operated by trained and qualified personnel only! This equipment is for industrial use only.

The following safety guidelines should always be used when operating the **DCA-70SSJU Series Generator**:

### GENERAL SAFETY

- **DO NOT** operate or service this equipment before reading this entire manual.



- This equipment should not be operated by persons under 18 years of age.

- **NEVER** operate this equipment without proper protective clothing, shatterproof glasses, steel-toed boots and other protective devices required by the job.



- **NEVER** operate this equipment when not feeling well due to fatigue, illness or taking medicine.



- **NEVER** operate this equipment under the influence of drugs or alcohol.



- **NEVER** use accessories or attachments, which are not recommended by MQ Power for this equipment. Damage to the equipment and/or injury to user may result.

- Manufacture does not assume responsibility for any accident due to equipment modifications.

- Whenever necessary, replace nameplate, operation and safety decals when they become difficult read.

- **ALWAYS** check the machine for loosened threads or bolts before starting.

- **NEVER** operate the generator in an explosive atmosphere or near combustible materials. An explosion or fire could result causing severe **bodily harm or even death**.

- **NEVER** touch the hot exhaust manifold, muffler or cylinder. Allow these parts to cool before servicing engine or generator.



- **High Temperatures** – Allow the engine to cool before performing service and maintenance functions. Contact with **hot!** components can cause serious burns.

- The engine of this generator requires an adequate free flow of cooling air. **NEVER** operate the generator in any enclosed or narrow area where free flow of the air is restricted. If the air flow is restricted it will

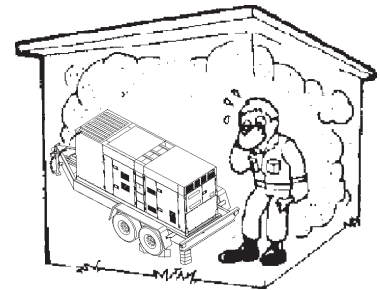

cause serious damage to the generator or engine and may cause injury to people. The generator engine gives off **DEADLY** carbon monoxide gas.

- **ALWAYS** make sure generator is properly grounded.

- **NEVER** use gas piping as an electrical ground.

- **DO NOT** place hands or fingers inside generator engine compartment when engine is running.

- **ALWAYS** make sure generator installation is accordance with **national and local electrical codes**.

- **ALWAYS** have a qualified electrician perform the generator wiring installation.

- **NEVER** power cables or cords **lay in water**.

- **NEVER stand in water** while AC power from the generator is being transfer to a load.

- **NEVER** use a defective or frayed power cable. Check the cable for cuts in the insulation.

- **NEVER** use a extension cord that is frayed or damaged where the insulation has been cut.

- **ALWAYS** make certain that proper extension cord has been selected for the job See Table 5.

- The electrical voltage required to operate the generator can cause severe injury or even death through physical contact with live circuits. Turn all circuit breakers **OFF** before performing maintenance on the generator.

# DCA-70SSJU SERIES — RULES FOR SAFE OPERATION

■ **ALWAYS** make sure that electrical circuits are properly *grounded* per the *National Electrical Code* (NEC) and local codes before operating generator. Severe *injury* or *death!* by electrocution can result from operating an ungrounded generator.

■ **ALWAYS** be sure the operator is familiar with proper safety precautions and operations techniques before using generator.

■ **ALWAYS** store equipment properly when it is not being used. Equipment should be stored in a clean, dry location out of the reach of children.

■ **ALWAYS** read, understand, and follow procedures in Operator's Manual before attempting to operate equipment.



## DANGER:

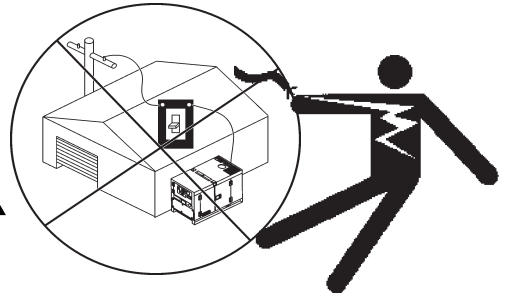

■ Backfeed to a utility system can cause *electrocution* and or property damage. **DO NOT** connect to any building's electrical system except through an approved device or after building main switch is opened. **ALWAYS** have a licensed electrician perform the installation

## DANGER:



**Never** use damaged or worn cables when connecting equipment to the generator. Make sure power connecting cables are securely connected to the generator's output terminals, insufficient tightening of the terminal connections may cause damage to the generator and electrical shock.



## DANGER:



**NEVER** grab or touch a live power cord with wet hands, the possibility exists of electrical shock, electrocution, and even *death!*

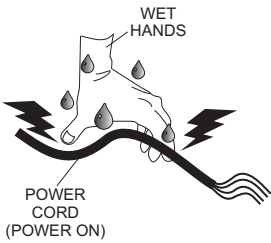

## CAUTION:



### Radiator

**DO NOT** touch or open any of the below mentioned components while the generator is running. Always allow sufficient time for the engine and generator to cool before performing maintenance.

1. **Radiator Cap** - Removing the radiator cap while the engine is hot will result in high pressurized, boiling water to gush out of the radiator, causing severe scalding to any persons in the general area of the generator.
2. **Coolant Drain Plug** - Removing the coolant drain plug while the engine is hot will result in hot coolant to gush out of the coolant drain plug, therefore causing severe scalding to any persons in the general area of the generator.
3. **Engine Oil Drain Plug** - Removing the engine oil drain plug while the engine is hot will result in hot oil to gush out of the oil drain plug, therefore causing severe scalding to any persons in the general area of the generator.

## DANGER:

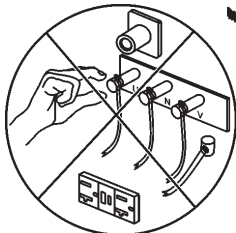

■ **NEVER** touch output terminals during operation. This is extremely dangerous. **ALWAYS** stop the machine and place the circuit breaker in the "OFF" position when contact with the output terminals is required. There exists the possibility of *electrocution, electrical shock or burn, which can cause severe bodily harm or even death!*

### Maintenance Safety

■ **NEVER** lubricate components or attempt service on a running machine.

■ **ALWAYS** allow the machine a proper amount of time to cool before servicing.



■ Keep the machinery in proper running condition.

■ Fix damage to the machine immediately and always replace broken parts.

# DCA-70SSJU— RULES FOR SAFE OPERATION

- **NEVER** Run engine without air filter. Severe engine damage may occur.
- **ALWAYS** service air cleaner frequently to prevent engine malfunction.
- **ALWAYS** disconnect the **negative battery terminal** before performing service on the generator.
- **ALWAYS** be sure the operator is familiar with proper safety precautions when operating the generator set.
- **ALWAYS** store equipment properly when not in use.
- **DO NOT** leave the generator running in the **manual mode** unattended.
- **DO NOT** allow unauthorized people to operate this equipment.
- **ALWAYS** read, understand, and follow procedures in Operator's Manual before attempting to operate equipment.
- Refer to the **John Deere Engine Owner's Manual** for engine technical questions or information.

## DANGER:



Pay close attention to ventilation when operating the generator inside tunnels and caves. The engine exhaust contains noxious elements. Engine exhaust must be routed to a ventilated area.



## Generator Grounding

To guard against electrical shock and possible damage to the equipment, it is important to provide a good **EARTH** ground.

Article 250 (Grounding) of the **National Electrical Code** (NEC) provides guide lines for proper grounding and specifies that the cable ground shall be connected to the grounding system of the building as close to the point of cable entry as practical.

**ALWAYS** be sure to use the ground terminal (green wire) when connecting a load to the UVWO output terminals.

## Battery

The battery contains acids that can cause injury to the eyes and skin. To avoid eye irritation, **always** wear safety glasses. Use well insulated gloves when picking up the battery. Use the following guidelines when handling the battery:

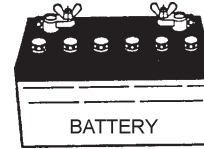

1. **DO NOT** drop the battery. There is the possibility of risk that the battery may explode.
2. **DO NOT** expose the battery to open flames, sparks, cigarettes etc. The battery contains combustible gases and liquids. If these gases and liquids come in contact with a flame or spark, an explosion could occur.
3. **ALWAYS** keep the battery charged. If the battery is not charged a buildup of combustible gas will occur.
4. **ALWAYS** keep battery charging and cables in good working condition. Repair or replace all worn cables.
5. **ALWAYS** recharge the battery in an vented air environment, to avoid risk of a dangerous concentration of combustible gases.
6. In case the battery liquid (dilute sulfuric acid) comes in contact with **clothing or skin**, rinse skin or clothing immediately with plenty of water.
7. In case the battery liquid (dilute sulfuric acid) comes in contact with your **eyes**, rinse eyes immediately with plenty of water, then contact the nearest doctor or hospital, and seek medical attention.

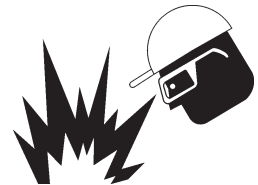

## Transporting

- **ALWAYS** shutdown engine before transporting.
- Tighten both fuel tank caps securely.
- If generator is mounted on a trailer, make sure trailer complies with all local and state safety transportation laws. See next page "**Towing Safety Precautions**" for basic towing techniques.

## Towing Safety Precautions

### CAUTION:



Conform to **Department of Transportation (DOT) Safety Towing Regulations** before towing generator.

To reduce the possibility of an accident while transporting the generator on public roads, always make sure the trailer that supports the generator and the towing vehicle are in good operating condition and both units are mechanically sound.

The following list of suggestions should be used when towing your generator:

- Make sure the hitch and coupling of the towing vehicle are rated equal to, or greater than the trailer "gross vehicle weight rating" (GVWR) of 6,000 lbs.
- **ALWAYS** inspect the hitch and coupling for wear. **NEVER** tow a trailer with defective hitches, couplings, chains etc.
- Check the tire air pressure on both towing vehicle and trailer. **Trailer tires should be inflated to 50 psi cold.** Also check the tire tread wear on both vehicles.
- **ALWAYS** make sure the trailer is equipped with a "Safety Chain".
- **ALWAYS** attach trailer's safety chains to towing vehicle properly.
- **ALWAYS** make sure the vehicle and trailer directional, backup, brake, and trailer lights are connected and working properly.
- The maximum speed for highway towing is **45 MPH** unless posted otherwise. Recommended off-road towing is not to exceed **10 MPH** or less depending on type of terrain.
- Place **chock blocks** underneath wheel to prevent **rolling**, while parked.
- Use the trailer's swivel jack to adjust the trailer height to a level position while parked.
- Avoid sudden stops and starts. This can cause skidding, or jack-knifing. Smooth, gradual starts and stops will improve towing.
- Avoid sharp turns.
- Trailer should be adjusted to a level position at all times when towing.
- Raise and lock trailer wheel stand in up position when transporting.
- DOT Requirements include the following:
  - Connect and test electric brake operation.
  - Secure portable power cables in cable tray with tie wraps.

### Emergencies

- **ALWAYS** know the location of the nearest **fire extinguisher**.



- **ALWAYS** know the location of the nearest **first aid kit**.



- In emergencies **always** know the location of the nearest phone or **keep a phone on the job site**. Also know the phone numbers of the nearest **ambulance, doctor** and **fire department**. This information will be invaluable in the case of an emergency.



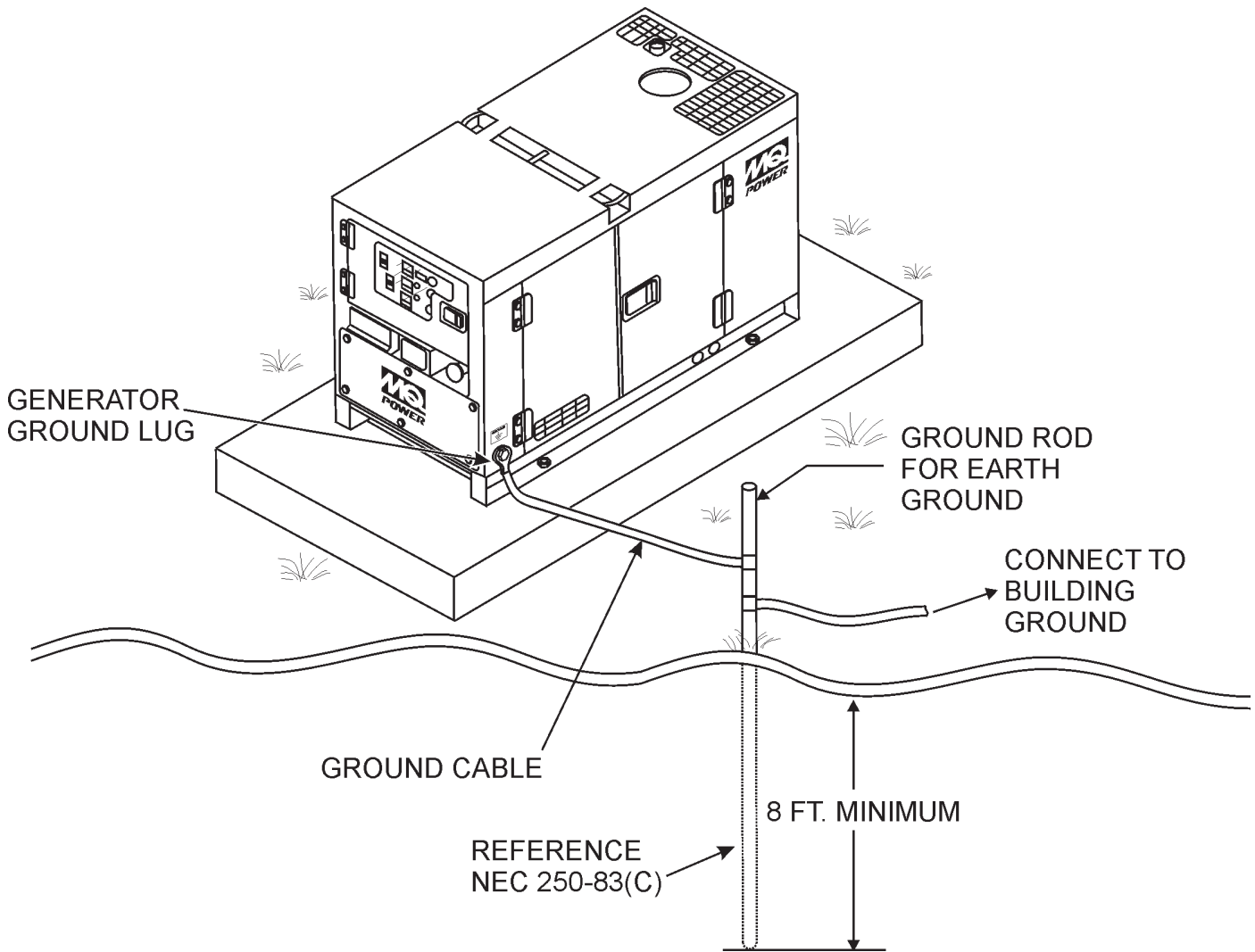

Figure 2. Typical Generator Grounding Application

## Outdoor Installation

Install the generator in a area that is free of debris, bystanders, and overhead obstructions. Make sure the generator is on secure level ground so that it cannot slide or shift around. Also install the generator in a manner so that the exhaust will not be discharged in the direction of nearby homes.

The installation site must be relatively free from moisture and dust. All electrical equipment should be protected from excessive moisture. Failure to do will result in deterioration of the insulation and will result in short circuits and grounding.

Foreign materials such as dust, sand, lint and abrasive materials have a tendency to cause excessive wear to engine and alternator parts.

## CAUTION:



Pay close attention to ventilation when operating the generator inside tunnels and caves. The engine exhaust contains noxious elements. Engine exhaust must be routed to a ventilated area.

## Indoor Installation

Exhaust gases from diesel engines are extremely poisonous. Whenever an engine is installed indoors the exhaust fumes must be vented to the outside. The engine should be installed at least two feet from any outside wall. Using an exhaust pipe which is too long or too small can cause excessive back pressure which will cause the engine to heat excessively and possibly burn the valves.

## Mounting

The generator must be mounted on a solid foundation (such as concrete) and set firmly on the foundation to isolate vibration of the generator when it is running. The generator must set at least 6 inches above the floor or grade level (in accordance to NFPA 110, Chapter 5-4.1). **DO NOT** remove the metal skids on the bottom of the generator. They are to resist damage to the bottom of the generator and to maintain alignment.

## Generator Grounding

To guard against electrical shock and possible damage to the equipment, it is important to provide a good **EARTH** ground.

Article 250 (Grounding) of the National Electrical Code (NEC) provides guide lines for proper grounding and specifies that the cable ground shall be connected to the grounding system of the building as close to the point of cable entry as practical.

NEC articles 250-64(b) and 250-66 set the following grounding requirements:

1. Use one of the following wire types to connect the generator to earth ground.
  - a. Copper - 10 AWG (5.3 mm<sup>2</sup>) or larger.
  - b. Aluminum - 8 AWG (8.4 mm<sup>2</sup>) or larger.
2. When grounding the generator (Figure 2) connect the ground cable between the lock washer and the nut on the generator and tighten the nut fully. Connect the other end of the ground cable to earth ground.
3. NEC article 250-52(c) specifies that the earth ground rod should be buried a minimum of 8 ft. into the ground.

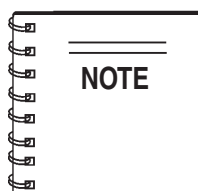

When connecting the generator to any buildings electrical system **ALWAYS** consult with a licensed electrician.

# DCA-70SSJU SERIES — TOWING SAFETY PRECAUTIONS

## Towing Safety Precautions

### CAUTION:



Check with your local county or state safety towing regulations before towing your generator.

To reduce the possibility of an accident while transporting the generator on public roads, always make sure the trailer (Figure 4) that supports the generator and the towing vehicle are in good operating condition and both units are mechanically sound.

The following list of suggestions should be used when towing your generator:

- Make sure the hitch and coupling of the towing vehicle are rated equal to, or greater than the trailer "gross vehicle weight rating" (GVWR).
- **ALWAYS** inspect the hitch and coupling for wear. **NEVER** tow a trailer with defective hitches, couplings, chains etc.
- Check the tire air pressure on both towing vehicle and trailer. Also check the tire tread wear on both vehicles.
- **ALWAYS** make sure the trailer is equipped with a "Safety Chain".

- **ALWAYS** attach trailer's safety chain to bumper of towing vehicle.
- **ALWAYS** make sure the vehicle and trailer directional, backup, brake, and trailer lights are connected and working properly.
- The maximum speed for highway towing is **55 MPH** unless posted otherwise. Recommended off-road towing is not to exceed **15 MPH** or less depending on type of terrain.
- Place *chocked blocks* underneath wheel to prevent **rolling**, while parked.
- Place *support blocks* underneath the trailer's bumper to prevent **tipping**, while parked.
- Use the trailer's hand winch to adjust the height of the trailer, then insert locking pin to lock wheel stand in place, while parked.
- Avoid sudden stops and starts. This can cause skidding, or jackknifing. Smooth, gradual starts and stops will improve gas mileage.
- Avoid sharp turns to prevent rolling.
- Remove wheel stand when transporting.
- **DO NOT** transport generator with fuel in tank.

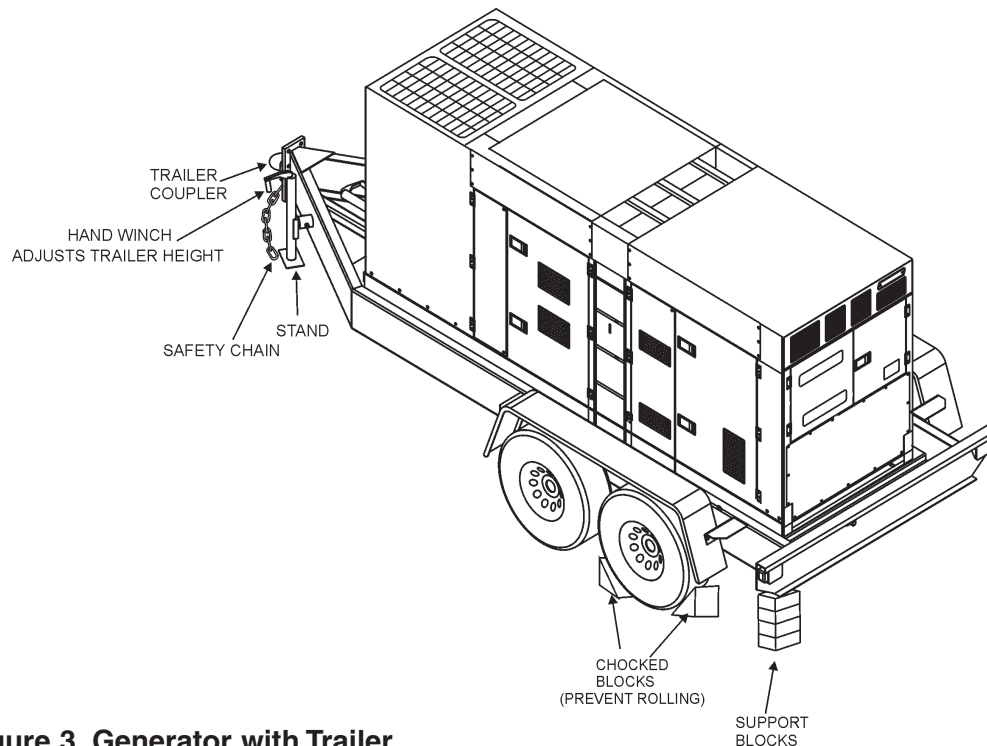

Figure 3. Generator with Trailer



## CAUTION:



**ALWAYS** make sure the trailer is in good operating condition. Check the tires for proper inflation and wear. Also check the wheel lug nuts for proper tightness.

### Explanation of Chart:

This section is to provide the user with trailer service and maintenance information. The service and maintenance guidelines referenced in this section apply a wide range of trailers. Remember periodic inspection of the trailer will ensure safe towing of the equipment and will prevent damage to the equipment and personal injury.

It is the purpose of this section to cover the major maintenance components of the trailer. The following trailer components will be discussed in this section:

- Brakes
- Tires
- Lug Nut Torquing
- Suspension
- Electrical
- Brake Troubleshooting Tables

Use the following definitions when reading Table 2.

1. **Fuel Cell** - Provides an adequate amount of fuel for the equipment in use. Fuel cells must be empty when transporting equipment.
2. **Braking System** - System employed in stopping the trailer. Typical braking systems are electric, surge, hydraulic, hydraulic-surge and air.
3. **GVWR**- Gross Vehicle Weight Rating (GVWR), is the maximum number of pounds the trailer can carry, including the fuel cell (empty).
4. **Frame Length** - Measurement is from the ball hitch to the rear bumper (reflector).
5. **Frame Length** - Measurement is from fender to fender
6. **Jack Stand** - Trailer support device with maximum pound requirement from the tongue of the trailer.
7. **Coupler** - Type of hitch used on the trailer for towing.
8. **Tire Size** - Indicates the diameter of the tire in inches (10,12,14, etc.), and the width in millimeters (175,185,205, etc.). The tire diameter must match the diameter of the tire rim.
9. **Tire Ply** - The tire ply (layers) number is rated in letters; 2-ply,4-ply,6-ply, etc.
10. **Wheel Hub** - The wheel hub is connected to the trailer's axle.
11. **Tire Rim** - Tires mounted on a tire rim. The tire rim must match the size of the tire.
12. **Lug Nuts** - Used to secure the wheel to the wheel hub. Always use a torque wrench to tighten down the lug nuts. See Table 17 and Figure 67 for lug nut tightening and sequence.
13. **Axle** - Indicates the maximum weight the axle can support in pounds, and the diameter of the axle expressed in inches. Please note that some trailers have a double axle. This will be shown as 2-6000 lbs., meaning two axles with a total weight capacity of 6000 pounds.
14. **Suspension** - Protects the trailer chassis from shocks transmitted through the wheels. Types of suspension used are leaf, Q-flex, and air ride.
15. **Electrical** - Electrical connectors (looms) are provided with the trailer so the brake lights and turn signals can be connected to the towing vehicle.
16. **Application** - Indicates which units can be employed on a particular trailer.

# DCA-70SSJU SERIES — TRAILER SPECIFICATIONS

**Table 2. Trailer Specifications**

MODEL	APPLICATION	FUEL CELL	BRAKE SYSTEM	GVWR	FRAME LENGTH	FRAME WIDTH	JACK STAND
TRLR-10W	SDW225, SGW250, TLW-300	NO	NO	1900LBS	96"	50"	800LB. FULL TILT WHEEL
TRLR-10	DCA10, TLG12, DCA-15	NO	NO	1900LBS	96"	50"	800LB. FULL TILT WHEEL
TRLR-10XF	DCA10, TLG-12, DCA15, TLW-300	52 GAL	NO	1900LBS	96"	50"	800LB. FULL TILT WHEEL
TRLR-225W	WELDERS, DA7000SS	NO	NO	2200LBS	85"	42"	800LB. FULL TILT WHEEL
TRLR-BLW400	BLW-400	NO	ELECTRIC	2700LBS	W/MAST 154" W/O 124"	55" (78" TALL)	800LB. FULL TILT WHEEL
TRLR-50X	DCA-25	NO	NO	2700LBS	124"	55"	800LB. FULL TILT WHEEL
TRLR-50XF	DCA-25	41 GAL	NO	2700LBS	124"	55"	800LB. FULL TILT WHEEL
TRLR-70W	DCA-45, -60, 70	NO	SURGE	7000LBS	186"	77"	2000LB. FLAT PAD
TRLR-70X	DCA-45, -60, 70	OPT	SURGE	7000LBS	138"	66"	2000LB. FLAT PAD
TRLR-70XF	DCA-45, -60, 70	53 GAL	SURGE	7000LBS	138"	66"	2000LB. FLAT PAD
TRLR-100XF	DCA-100, 125	150 GAL	HYDRAULIC SURGE	7000LBS	190"	76"	2000LB. FLAT PAD
TRLR-85/125	DCA-85, 100, 125	145 GAL	HYDRAULIC	10000LBS	186"	77"	2000LB. FLAT PAD
TRLR-150XF	DCA-150, 180	200 GAL	HYDRAULIC SURGE	11160LBS	204"	84"	5000 LB. FLAT PAD
TRLR-220XF	DCA-220	250 GAL	HYDRAULIC SURGE	14000LBS	222"	83"	5000 LB. FLAT PAD
TRLR-300XF	DCA-300	250 GAL	HYDRAULIC SURGE	18000LBS	238"	83"	5000 LB. FLAT PAD
TRLR-400XF	DCA-400	350 GAL	ELECTRIC	18000LBS	238"	83"	5000 LB. FLAT PAD
TRLR-600XF	DCA-600, 800	550 GAL	AIR	30000LBS	384"	96"	5000 LB. FLAT PAD
TRLR-800SX	DCA-600, 800	550 GAL	AIR	30000LBS	384"	96"	5000 LB. FLAT PAD

# DCA-70SSJU SERIES — TRAILER SPECIFICATIONS

**Table 2. Specifications (Con't)**

MODEL	COUPLER	TIRES	WHEELS	AXLE	HUBS	SUSPENSION	ELECTRICAL
TRLR-10W	2" BALL CLASS 2 ADJUSTABLE	175-13C	13"X4.50"	2200# 2X2	5 LUG	3 LEAF	4 WIRE LOOM W/ 4 POLE FLAT
TRLR-10	2" BALL CLASS 2 ADJUSTABLE	175-13C	13"X4.5"	2200#2X2	5 LUG	3 LEAF	4 POLE FLAT
TRLR-10XF	2" BALL CLASS 2 ADJUSTABLE	175-13C	13"X4.5"	2200#2X2	5 LUG	3 LEAF	4 POLE FLAT
TRLR-225W	2" BALL CLASS 2 ADJUSTABLE	175-13B	13X4.5"	2200#2X2	5 LUG	Q FLEX	4 POLE FLAT
TRLR-BLW 400	2" BALL CLASS 2 ADJUSTABLE	175-13C	13 X 4.5"	2200#2X2	5 LUG	3 LEAF	4 POLE FLAT
TRLR-50X	2" BALL CLASS	B78-13LRC	13"X4.50"	3500lbs. 2-3/8"	5 LUG	4 LEAF	4 POLE RUBBER FLAT
TRLR-50XF	2" BALL CLASS	B78-13LRC	13"X4.50"	3500lbs. 2-3/8"	5 LUG	4 LEAF	4 POLE RUBBER FLAT
TRLR-70W	2" BALL CLASS 3" ADJUSTABLE	205-14C BIAS (4)	14"X5"	3500lbs. 3"	5 LUG	5 LEAF	4 POLE RUBBER FLAT
TRLR-70X	2" BALL CLASS 3" ADJUSTABLE	205-14C BIAS (4)	14"X5"	3500lbs 3"	5 LUG	5 LEAF	4 POLE RUBBER FLAT
TRLR-70XF	2" BALL CLASS 3" ADJUSTABLE	205-14C BIAS (4)	14"X5"	3500lbs. 3"	5 LUG	5 LEAF	4 POLE RUBBER FLAT
TRLR-100XF	ADJUSTABLE 2- 5/6 OPT 3" EYE	205-15C BIAS (4)	14"X5.5"	3500lbs 3"	5 LUG	5 LEAF	4 WIRE LOOM
TRLR-85/125	ADJUSTABLE 2- 5/6 OPT 3" EYE	ST225/75R15D RADIAL (4)	14"x6"	(2)-6000lbs	6 LUG	7 LEAF	4 WIRE LOOM
TRLR-150XF	3" BALL EYE	750-16 E BIAS (4)	16"X7"	(2)-6000lbs	8 LUG	7 LEAF	4 WIRE LOOM
TRLR-220XF	3" EYE ADJUSTABLE	ST235/85R16E RADIAL(4)	16"X7"	(2)-7000lbs	8 LUG	Q FLEX	4 WIRE LOOM
TRLR-300XF	3" EYE ADJUSTABLE	ST235/85R16E RADIAL(6)	16"X7"	(2)-6000lbs	8 LUG	Q FLEX	4 WIRE LOOM
TRLR-400XF	3" EYE ADJUSTABLE	ST235/85R16E RADIAL(6)	16"X7"	(3)-7000lb- s.	8 LUG	Q FLEX	4 WIRE LOOM
TRLR-600XF	5TH WHEEL	ST215/75R17.5H RADIAL (8)	16"X7"	(3)-10000l- bs	8 LUG	7 LEAF	6 WIRE LOOM
TRLR-800AR	5TH WHEEL	ST215/75R17.5H RADIAL (8)	16"X7"	(3)-10000l- bs	8 LUG	AIR-RIDE	6 WIRE LOOM

# DCA-70SSJU SERIES — GENERATOR DECALS

The DCA-70SSJU Series generator is equipped with a number of safety decals. These decals are provided for operator safety and maintenance information. The illustration below and on the preceding page show the decals as they appear on the machine. Should any of these decals become unreadable, replacements can be obtained from your dealer.

**OPERATING PROCEDURES**

**Manual Starting**

1. Check the engine oil, coolant, and fuel levels. Replenish if necessary.
2. Place all Generator Circuit Breakers in the "OFF" position and close all doors.
3. Check that the Voltage select switch (or the Voltage change-over board) is present at desired voltage.  
(In case of generator having multiple voltage ratings.)
4. Set the Engine speed switch to the "LOW" position.
5. Turn the Auto-Off/Reset-Manual switch to the "Manual" position to start the engine. If the engine fails to start in the specified number of attempts, the overcrank lamp will indicate and the Auto-Off/Reset-Manual switch must be returned to the "Off/Reset" position before proceeding.
6. When the engine is ready for starting during cold weather operating conditions, push the intake heater button for approximately 30 seconds. Start engine using the Auto-Off/Reset-Manual switch to the "Manual" position. As soon as the engine starts, release the button.  
(If the engine still does not start, utilize the water heater until water is warm. (If additional water heater is supplied).)
7. After starting, allow the engine to run for 1 or 2 minutes to warm-up. At temperatures below freezing, this time period must be extended to 2 to 4 minutes.
8. When the engine starts, immediately check for abnormal noise, vibration, fluid leakage or any indication of a problem. Check the control panel gauges. If all is normal, let the engine remain at the "Low" position for a short time, depending on the ambient conditions, warm up.
9. After sufficient warm-up time has elapsed, set the Engine speed switch to the "High" position and the unit is ready for operation.
10. Check the NO-Load speed as shown in the table below.  
①No operation—Approx. 60 Dps (1200rpm)
11. Adjust the Voltage Regulator to the specified voltage.

M35200010

P/N M352000103

**SAFETY INSTRUCTIONS**

Improper operation of this machine can cause severe injury or death.

- Read the instruction manual carefully before operating or servicing.

This machine should only be operated by a person with sufficient knowledge and skill to ensure safe operation.

High voltage circuits are located inside the output terminal cover and control panel.

- Close the cover and control panel before operating.

Moving parts and hot surfaces are contained within the enclosure.

- Close all doors and lock them before operating.

M92010030

P/N M9520100304

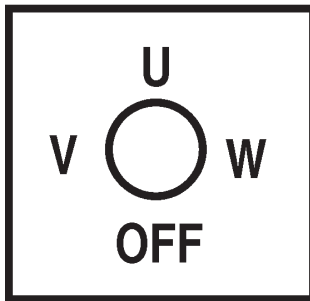

P/N M9520000104

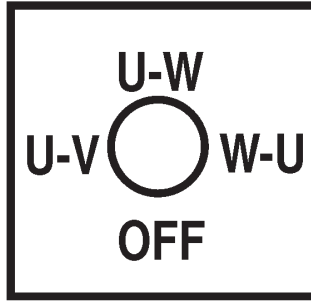

P/N M9520000204



P/N M950000004



P/N M9510200002



P/N M9500300104



P/N M9500300004

**OVER CURRENT RELAY**

If it is Impossible to reset the CIRCUIT BREAKER, open the control panel and push the RESET BUTTON as below.

M92020010

P/N M9520200104



P/N M9500500104

**DIESEL FUEL**  
M90050000

P/N M9500500004

**WATER • OIL CHECK AND FILL DAILY**  
M90300010

P/N M9503000103

# DCA-70SSJU SERIES — GENERATOR DECALS

	<b>⚠ WARNING</b>
	<b>ELECTRIC SHOCK HAZARD</b> <ul style="list-style-type: none"> <li>Do not touch internal wiring or connections while this machine is operating.</li> <li>Turn power off before servicing.</li> </ul>

M92010000

P/N M9520100004

<b>DANGER</b>
<b>HIGH VOLTAGE</b>

M92010040

P/N M9520100401

<b>NOTE</b>
<p>To use 50 AMP receptacles, adjust the voltage selector switch to the single phase position and the main line circuit breaker to the on position.</p>

M1500020

P/N M1550000204

	<b>⚠ WARNING</b>	<b>⚠ WARNING</b>	<b>⚠ WARNING</b>
	<b>ELECTRIC SHOCK HAZARD</b> <ul style="list-style-type: none"> <li>Do not touch output terminals while this machine is operating.</li> <li>Turn power off before servicing.</li> </ul>	<b>ELECTRIC SHOCK HAZARD</b> <ul style="list-style-type: none"> <li>Always complete the grounding path from the ground terminal on this genset to an external grounding source. See instruction manual for details.</li> </ul>	<ul style="list-style-type: none"> <li>Before connecting this generator to any building's electrical system, a licensed electrician must install an isolation (transfer) switch.</li> <li>Serious injury or death may result without this transfer switch.</li> </ul>

M92010050

P/N M9520100503

	<b>⚠ WARNING</b>
	<b>HOT COOLANT can cause severe burns.</b> <ul style="list-style-type: none"> <li>Do not remove cap if radiator is hot.</li> </ul>

M90310000

P/N M9503100004

	<b>⚠ WARNING</b>
	<b>ENGINE EXHAUST can cause severe injury or death.</b> <ul style="list-style-type: none"> <li>Use only in open, well ventilated areas or vent exhaust outside.</li> </ul>

M90320000

P/N M9503200004

<b>⚠ CAUTION</b>
<p>Stop engine before switching.</p>

M92010020

P/N M9520100204

	<b>⚠ CAUTION</b>
	<b>MOVING PARTS can cause severe injury.</b> <ul style="list-style-type: none"> <li>Do not operate with doors open.</li> <li>Stop engine before servicing.</li> </ul>

M90300000

P/N M9503000004

	<b>⚠ WARNING</b>
	<b>HOT PARTS can burn skin.</b> <ul style="list-style-type: none"> <li>Do not touch until the machine has sufficiently cooled.</li> </ul>

M91010000

P/N M9510100004

	<b>⚠ WARNING</b>
	<b>ELECTRIC SHOCK HAZARD</b> <ul style="list-style-type: none"> <li>Do not touch internal wiring or connections while this machine is operating.</li> <li>Turn power off before servicing.</li> </ul>

M92010000

P/N M9520100004

## DCA-70SSJU Series Familiarization

### Generator

The MQ Power Model DCA-70SSJU Series is a 26 kW **generator** (Figure 4) that is designed as a high quality portable (requires a trailer for transport) power source for telecom sites, lighting facilities, power tools, submersible pumps and other industrial and construction machinery.

### Engine Operating Panel

The "Engine Operating Panel" is provided with the following:

- Tachometer
- Water Temperature Gauge
- Oil Pressure Gauge
- Charging Ammeter Gauge
- Engine Throttle Handle (Up to S/N 7302410)
- Fuel Level Gauge
- Engine Speed Switch (S/N 7302141~)
- Cold Starting Button
- Panel Light
- Panel Light Switch
- Ignition/Preheat Switch ( Up to S/N 7302410)
- Auto ON/OFF Engine Controller (S/N 7302141~)

### Generator Control Panel

The "Generator Control Panel" is provided with the following:

- Output Voltage Adjustment Knob
- Frequency Meter (Hz)
- AC Ammeter (Amps)
- AC Voltmeter (Volts)
- Ammeter Change-Over Switch
- Voltmeter Change-Over Switch
- Voltage Regulator
- Over-Current Relay

### Output Terminal Panel

The "Output Terminal Panel" is provided with the following:

- Three 250 VAC output receptacles (CS-6369), 50 amps
- Three auxiliary circuit breakers, 250V @50 amps
- Two 125 VAC output receptacles, (GFCI), 20 amps
- Two GFCI circuit breakers, 120V @ 20amps
- Five output terminal lugs (3Ø power)

### Control Box

The "Control Box" is provided with the following:

- 3-Pole, 250 VAC, 175 amp Main Circuit Breaker
- Automatic Voltage Regulator
- Current Transformer
- Emergency Relay

### Open Delta Excitation System

The DCA-70SSJU Series generator is equipped with the state of the art "**Open-Delta**" excitation system. The open delta system consist of an electrically independent winding wound among stationary windings of the AC output section.

There are four connections of the open delta A, B, C and D. During steady state loads, the power from the voltage regulator is supplied from the parallel connections of A to B, A to D, and C to D. These three phases of the voltage input to the voltage regulator are then rectified and are the excitation current for the exciter section.

When a heavy load, such as a motor starting or a short circuit occurs, the automatic voltage regulator (AVR) switches the configuration of the open delta to the series connection of B to C. This has the effect of adding the voltages of each phase of provide higher excitation to the exciter section and thus better voltage response during the application of heavy loads.

The connections of the AVR to the AC output windings are for sensing only. No power is required from these windings.

The open-delta design provides virtually unlimited excitation current, offering maximum motor starting capabilities. The excitation does not have a "**fixed ceiling**" and responds according the demands of the required load.

### Engine

The **DCA-70SSJU** and **DCA-70SSJU2** are powered by a 4 cycle, water cooled, turbocharged **JOHN DEERE Model 4045TF150 Diesel** Engine. This engine is designed to meet every performance requirement for the generator. Reference Table 1 for engine specifications.

In keeping with MQ Power's policy of constantly improving its products, the specifications quoted herein are subject to change without prior notice.

### Mechanical Governor System

The mechanical governor system control the RPM of the engine. When the engine demands increase or decrease, the mechanical governor system regulates the frequency variation to  $\pm 5\%$ . The electronic governor option increases frequency variation to  $\pm 0.25\%$ .

### Extension Cables

When electric power is to be provided to various tools or loads at some distance from the generator, extension cords are normally used. Cables should be sized to allow for distance in length and amperage so that the voltage drop between the generator and point of use (load) is held to a minimum. Use the cable selection chart (Table 5) as a guide for selecting proper extension cable size.

# DCA-70SSJU SERIES — MAJOR COMPONENTS

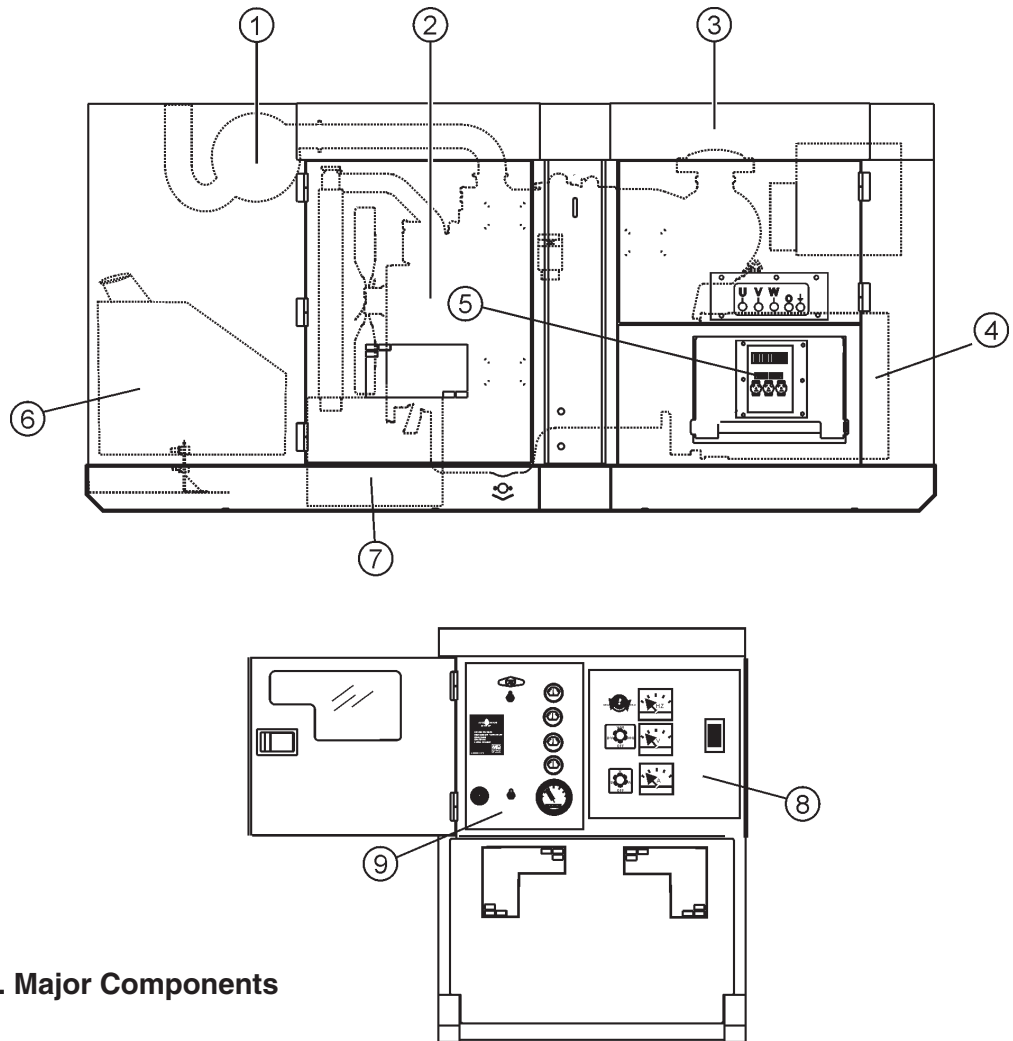
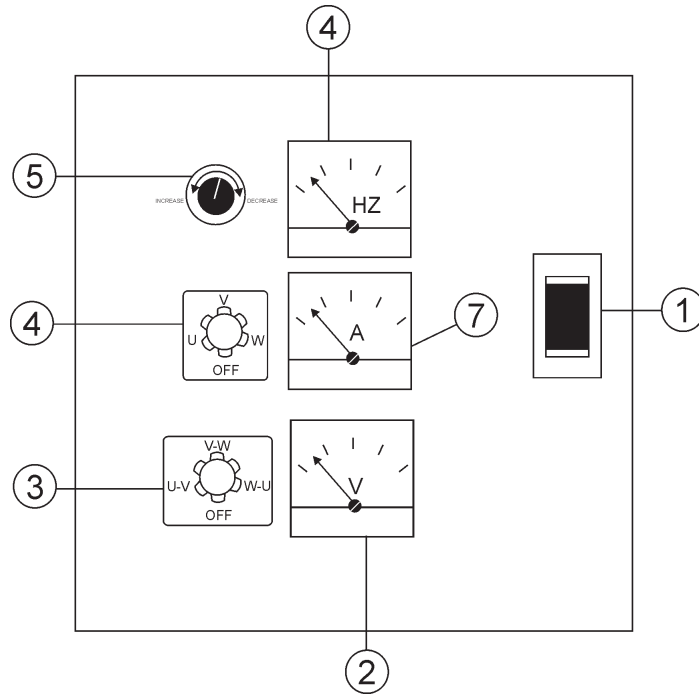

Figure 4. Major Components

**Table 3. Generator Major Components**

ITEM NO.	DESCRIPTION
1	Muffler Assembly
2	Engine Assembly
3	Enclosure Assembly
4	Generator Assembly
5	Output Terminal Assembly
6	Fuel Tank Assembly
7	Battery Assembly
8	Generator Control Panel Assembly
9	Engine Operating Panel Assembly

# DCA-70SSJU SERIES — GENERATOR CONTROL PANEL



**Figure 5. Generator Control Panel**

The definitions below describe the controls and functions of the DCA-70SSJU Series "**Generator Control Panel**" (Figure 5).

1. **Main Circuit Breaker** – This three-pole, 175 amp main breaker is provided to protect the **UVWO** output terminals from overload.
2. **AC Ammeter** – Indicates the amount of current the load is drawing from the generator per leg selected by the ammeter phase-selector switch.
3. **Ammeter Change-Over Switch** – This switch allows the AC ammeter to indicate the current flowing to the load connected to any phase of the output terminals, or to be switched off. This switch does not effect the generator output in any fashion, it is for current reading only.
4. **Voltmeter Change-Over Switch** – This switch allows the AC voltmeter to indicate phase to phase voltage between any two phases of the output terminals or to be switched off.
5. **Voltage Regulator Control** – Allows  $\pm 15\%$  manual adjustment of the generator's output voltage.
6. **Frequency Meter** – Indicates the output frequency in hertz (Hz). Normally 60 Hz  $\pm 1$  Hz .
7. **AC Voltmeter** – Indicates the output voltage present at the **UVWO** terminals.

Located behind the generator control panel is the **Generator Control Box**. This box contains some of the necessary electronic components required to make the generator function.

The "**Control Box**" is equipped with the following major components:

- Over-Current Relay
- Voltage Rectifier
- Starter Relay
- Engine Controller (Computer Controlled)
- Current Transformer
- Voltage Selector Switch

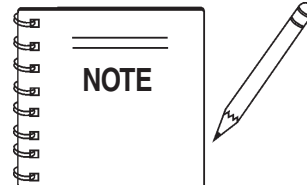

Remember the **overcurrent relay** monitors the current flowing from the **UVWO** output terminals to the load.

In the event of a short circuit or over current condition, it will automatically trip the main 250 amp breaker.

To restore power to the **UVWO** output terminals, press the **reset** button on the overcurrent relay and place the **main** circuit breaker in the **closed** position (**ON**).



# DCA-70SSJU SERIES — ENGINE OPERATING PANEL

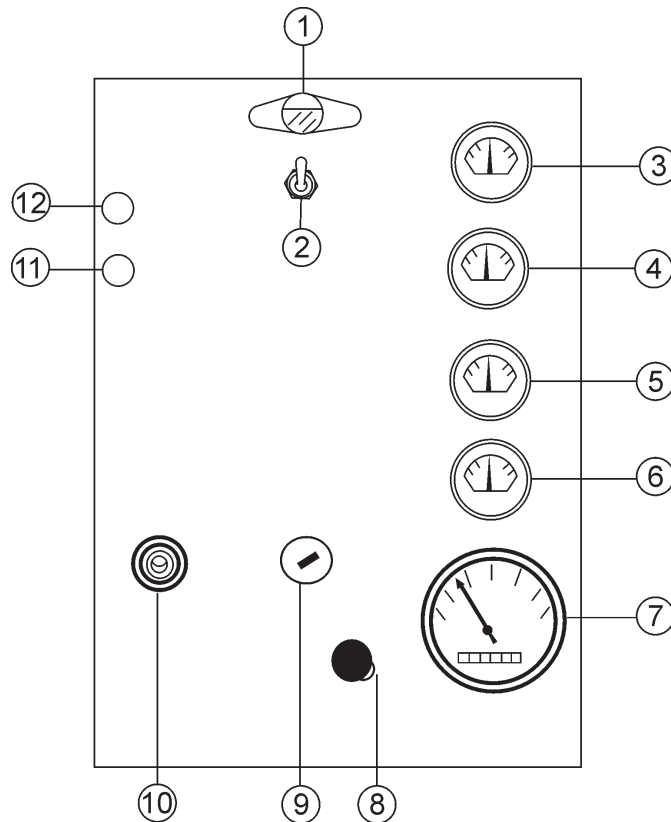

**Figure 6. Engine Operating Panel Up To S/N 73002140**

The definitions below describe the controls and functions of the DCA-70SSJU - "**Engine Operating Panel**" (Figure 6), up to **S/N 73002140**.

1. **Panel Light** – Normally used in dark areas or at night time. When activated, panel lights will illuminate. When the generator is not in use be sure to turn the panel light switch to the OFF position.
2. **Panel Light Switch** – When activated will turn on control panel light.
3. **Oil Pressure Gauge** – During normal operation this gauge be should read in the "**GREEN**" zone. When starting the generator the oil pressure may read a little bit higher, but after the engine warms up the oil pressure should return to the green zone.
4. **Water Temperature Gauge** – During normal operation this gauge be should read in the "**GREEN**" zone.
5. **Charging Ammeter Gauge** – Indicates the current being supplied by the engine's alternator which provides current for generator's control circuits and battery charging system.
6. **Fuel Gauge** - Indicates amount of diesel fuel available.
7. **Tachometer** – Indicates engine speed in RPM's for 60 Hz operation. This meter should indicate 1800 RPM's when the rated load is applied. In addition a built in hour meter will record the number of operational hours that the generator has been in use.
8. **Engine Speed Throttle**- This lever controls the speed of the engine (low or high).
9. **Ignition Switch** – Turns the engine on, off or to preheat the engine.
10. **Cold Starting Button** – Used to warm the engine glow plugs in cold weather conditions. Press and hold the engine cold starting button until the button illuminates.
11. **Water Temperature Warning Light** - Indicates if the coolant is low. This warning will shut off the engine.
12. **Oil Pressure Warning Light** - This will indicate if the oil pressure is too low or high. This warning will shut off the engine.

# DCA-70SSJU SERIES — ENGINE OPERATING PANEL

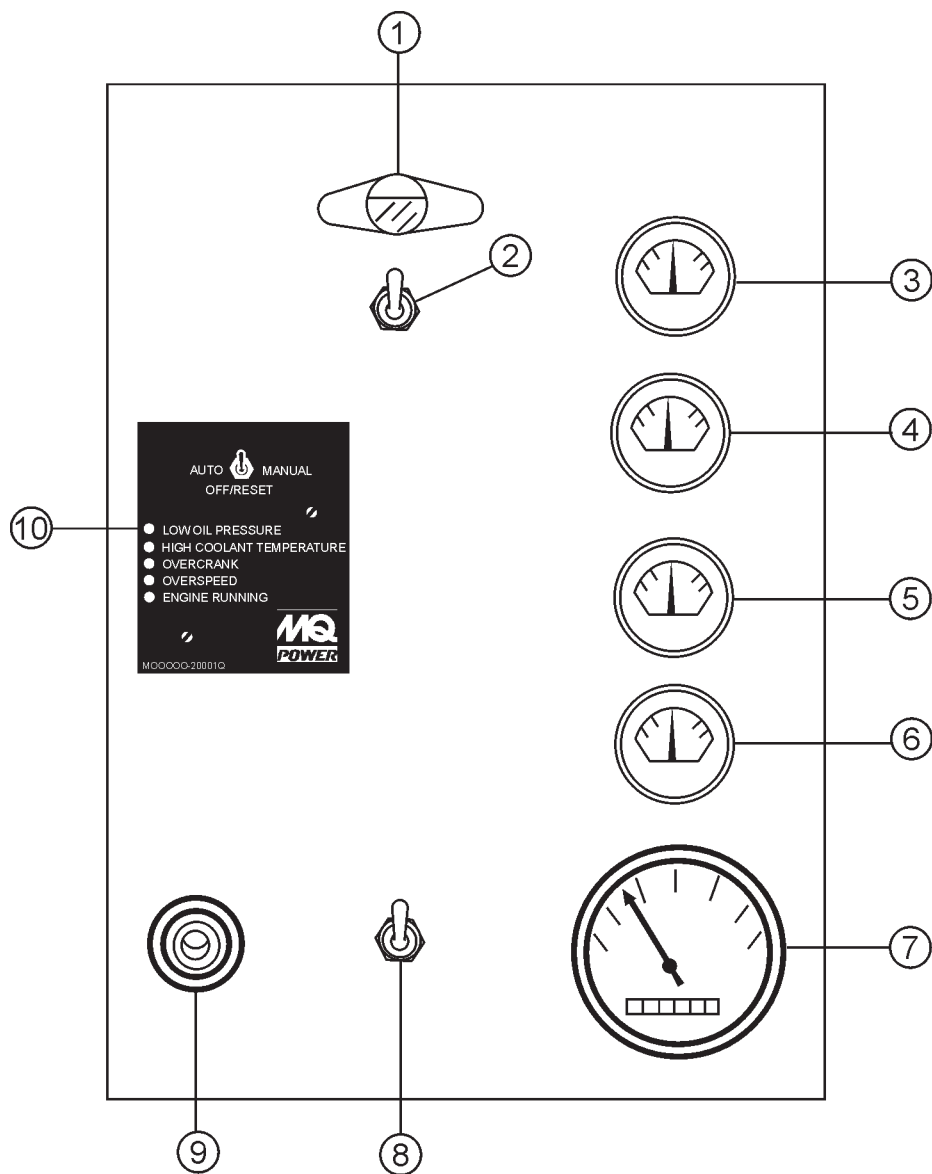

Figure 7. Engine Operating Panel From S/N 73002141~

## DCA-70SSJU SERIES — ENGINE OPERATING PANEL

The definitions below describe the controls and functions of the DCA-70SSJU2 "Engine Operating Panel" (Figure 7) from S/N 73002141~.

1. **Panel Light** – Normally used in dark areas or at night time. When activated, panel lights will illuminate. When the generator is not in use be sure to turn the panel light switch to the **OFF** position.
2. **Panel Light Switch** – When activated will turn on control panel light.
3. **Oil Pressure Gauge** – During normal operation this gauge be should read between 42 to 71 psi. When starting the generator the oil pressure mar read a little bit higher, but after the engine warms up the oil pressure should return to the green zone.
4. **Water Temperature Gauge** – During normal operation this gauge be should read between 165° and 203°F.
5. **Charging Ammeter Gauge** – Indicates the current being supplied by the engine's alternator which provides current for generator's control circuits and battery charging system.
6. **Fuel Gauge** - Indicates amount of diesel fuel available.
7. **Tachometer** – Indicates engine speed in RPM's for 60 Hz operation. This meter should indicate 1800 RPM's when the rated load is applied. In addition a built in hour meter will record the number of operational hours that the generator has been in use.
8. **Engine Speed Switch** - This switch controls the speed of the engine (low or high).
9. **Cold Starting Button** – Used to warm the engine glow plugs in cold weather conditions. Press and hold the engine cold starting button until the button illuminates.



10. **Auto On/Off Engine Controller** – This controller as a vertical row of status LED's (inset), that when lit, indicate that an engine malfunction (fault), has been detected. When a fault has been detected the engine controller will evaluate the fault and all major faults will shutdown the generator.



During **cranking cycle**, The MPEC will attempt to crank the engine for 10 seconds before disengaging. If the engine does not engage (start) by the third attempt, the engine will be shutdown by the engine controller's "**OVER CRANK PROTECTION**" mode. If the engine engages at a speed (RPM's) that is not safe, the controller will shutdown the engine by initializing the "**Over Speed Protection**" mode.

Also the engine controller will shutdown the generator in the event of low oil pressure, high coolant temperature, low coolant level, and loss of magnetic pickup. These conditions can be observed by monitoring the **LED** status indicators on the front of the controller module.

- A. **Off/Manual/Auto Switch** – This switch controls the running of the generator. If this switch is left in the "**OFF**" position, the generator will not run. When this switch is set to the **manual** position, the generator will start immediately.

If the generator is to be connected to a building's AC power source via a transfer switch (isolation), place the switch in the **auto** position. In this position the generator will monitor the AC line output from the building's power source.

- B. **Low Oil Pressure** – Indicates the engine pressure has fallen below 15 psi. The oil pressure is detected using variable resistive values from the oil pressure sending unit. This is considered a **major** fault.
- C. **High Coolant Temperature** – Indicates the engine temperature has exceeded 215°F. The engine temperature is detected using variable resistive values from the temperature sending unit. This is considered a **major** fault.
- D. **Overcrank Shutdown** – Indicates the unit has attempted to start a pre-programmed number of times, and has failed to start. The number of cycles and duration are programmable. It is pre-set at 3 cycles with a 10 second duration. This is considered a **major** fault.
- E. **Overspeed Shutdown** – Indicates the engine is running at an unsafe speed. This is considered a **major** fault.
- F. **Engine Running** – Indicates that engine is running at a safe operating speed.

# DCA-70SSJU SERIES — OUTPUT TERMINAL PANEL FAMILIARIZATION

## Output Terminal Familiarization

The “**Output Terminal Panel**” (Figure 8) is provided with the following:

- Three (3) 240V output receptacles, 50 amp
- Three (3) Circuit Breakers 240V @50 amps
- Two (2) 120V GFCI receptacles, 20 amp
- Two (2) GFCI Circuit Breakers 120V @ 20 amps
- One Main Circuit Breaker 250V @175 amps
- Five (5) Output Terminal Lugs

## Output Terminal Panel

The **Output Terminal Panel** (Figure 8) shown below is located on the right-hand side (left from control panel) of the generator. Lift up on the cover to gain access to receptacles and terminal lugs.

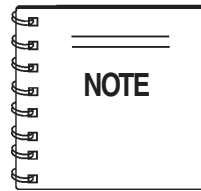

Terminal legs “O” and “Ground” are considered **bonded grounds**.

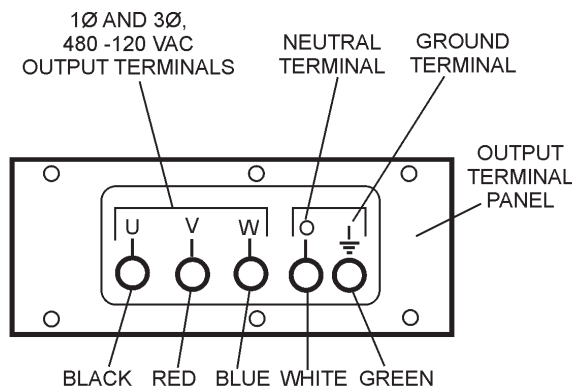
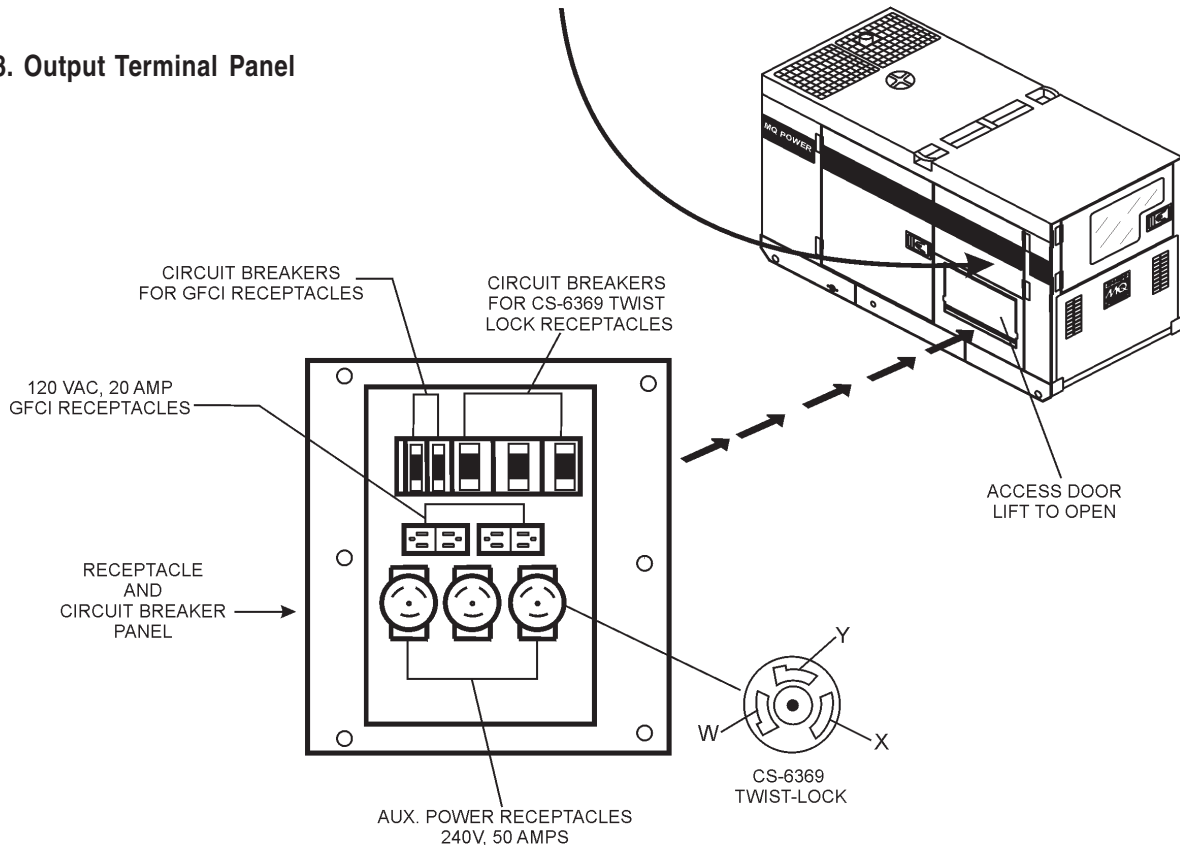

Figure 8. Output Terminal Panel



# DCA-70SSJU SERIES — OUTPUT TERMINAL PANEL FAMILIARIZATION

## 120 VAC GFCI Receptacles

There are two 120 VAC, 20 amp GFCI (Duplex Nema 5-20R) receptacles provided on the output terminal panel. These receptacles can be accessed in **any voltage selector switch** position. Each receptacle is protected by a 20 amp circuit breaker. These breakers are located directly above the GFCI receptacles. Remember the load output (current) of both GFCI receptacles is dependent on the load requirements of the UVWO terminals.

Pressing the **reset** button resets the GFCI receptacle after being tripped. Pressing the "**Test Button**" (See Figure 9) in the center of the receptacle will check the GFCI function. Both receptacles should be tested at least once a month.

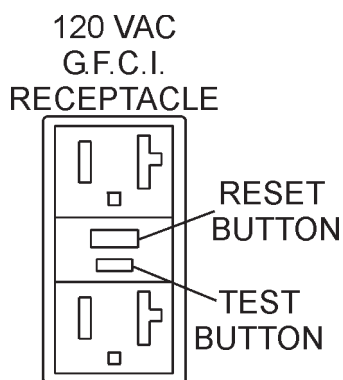

Figure 9. G.F.C.I. Receptacle

## Twist Lock Dual Voltage 120/240 VAC Receptacles

There are three 240 VAC, 50 amp auxilliary twist-lock (CS-6369) receptacles (Figure 10) provided on the output terminal panel. These receptacles can **only** be accessed when the voltage selector switch is placed in the **single-phase 240/120 position**.

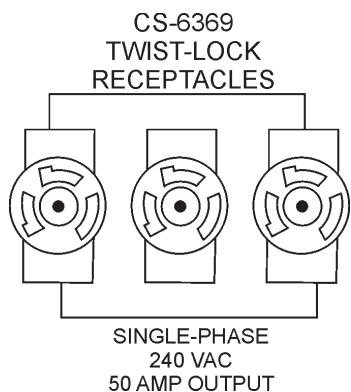

Figure 10. 240 VAC Twist-Lock Auxiliary Receptacles

Each auxilliary receptacle is protected by a 50 amp circuit breaker. These breakers are located directly above the GFCI receptacles. Remember the load output (current) on all three receptacles is dependent on the load requirements of the UVWO terminals.

Turn the **voltage regulator control knob** (Figure 11) on the control panel to obtain the desired voltage. Turning the knob clockwise will **increase** the voltage, turning the knob counter-clockwise will **decrease** the voltage.



Figure 11. Voltage Regulator Control Knob

## Removing the Plastic Face Plate (UVWO Terminals)

The UVWO terminal lugs are protected by a plastic face plate cover (Figure 12). Un-lock the locking latch, and lift the terminal cover to gain access to the plastic face plate. Remove the screws securing the face plate to the terminal enclosure, then lift the plastic hinged face plate.

After the load wires have been securely attached to the UVWO terminals, reinstall the plastic face plate. Place the terminal cover in the down position and secure the locking latch.

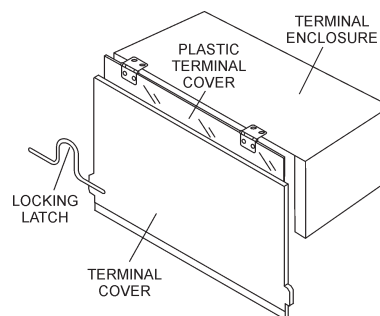

Figure 12. Plastic Face Plate (UVWO Terminals)

# DCA-70SSJU SERIES — OUTPUT TERMINAL PANEL FAMILIARIZATION

## Connecting Loads

Loads can be connected to the generator by the **UVW0** terminal lugs or the convenience receptacles. (See Figure 13). Make sure to read the operation manual before attempting to connect a load to the generator.

To protect the UVW0 output terminals from overload, a 3-pole, 175 amp, **main** circuit breaker is provided. Make sure to switch **ALL** circuit breakers to the "OFF" position prior to starting the engine.

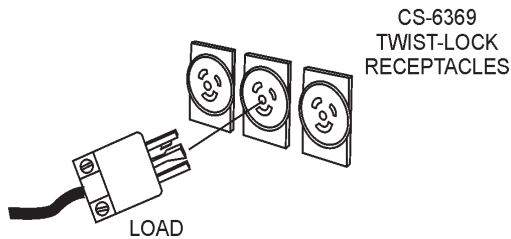
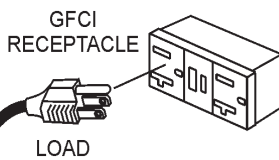
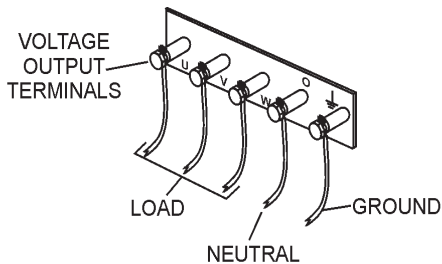

Figure 13. Connecting Loads

## Over Current Relay

An **over current relay** (Figure 14) is connected to the main circuit breaker. In the event of an overload, both the circuit breaker and the over current relay may trip. If the circuit breaker can not be reset, the **reset button** on the over current relay must be pressed. The over current relay is located in the control box.

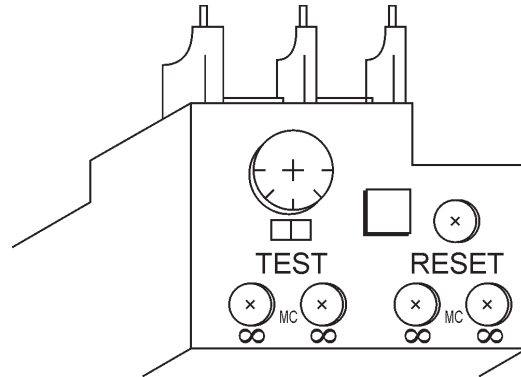

Figure 14. Over Current Relay

# DCA-70SSJU SERIES — LOAD APPLICATION

## Single Phase Load

Always be sure to check the nameplate on the generator and equipment to insure the wattage, amperage and frequency requirements are satisfactorily supplied by the generator for operating the equipment.

Generally, the wattage listed on the nameplate of the equipment is its rated output. Equipment may require 130—150% more wattage than the rating on the nameplate, as the wattage is influenced by the efficiency, power factor and starting system of the equipment.

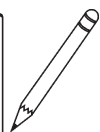
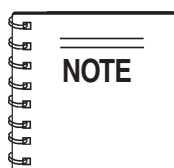

If wattage is not given on the equipment's name plate, approximate wattage may be determined by multiplying nameplate voltage by the nameplate amperage.

$$\text{WATTS} = \text{VOLTAGE} \times \text{AMPERAGE}$$

The power factor of this generator is 0.8. See Table 4 below when connecting loads.

Type Of Load	Power Factor
Single-phase induction motors	0.4 - 0.75
Electric heaters, incandescent lamps	1.0
Fluorescent lamps, mercury lamps	0.4 - 0.9
Electronic devices, communication equipment	1.0
Common power tools	0.8

Table 5. Cable Selection (60 Hz, Single Phase Operation)

Current in Amperes	Load In Watts		Maximum Allowable Cable Length			
	At 120 Volts	At 240 Volts	#10 Wire	#12 Wire	#14 Wire	#16 Wire
2.5	300	600	1000 ft.	600 ft.	375 ft.	250 ft.
5	600	1200	500 ft.	300 ft.	200 ft.	125 ft.
7.5	900	1800	350 ft.	200 ft.	125 ft.	100 ft.
10	1200	2400	250 ft.	150 ft.	100 ft.	
15	1800	3600	150 ft.	100 ft.	65 ft.	
20	2400	4800	125 ft.	75 ft.	50 ft.	

CAUTION: Equipment damage can result from low voltage.

## Three Phase Load

When calculating the power requirements for 3-phase power use the following equation:

$$\text{KVA} = \frac{\text{VOLTAGE} \times \text{AMPERAGE} \times 1.732}{1000}$$

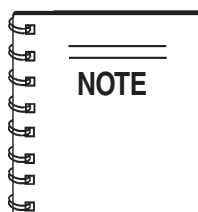

Motors and motor-driven equipment draw much greater current for starting than during operation.

An inadequate size connecting cable which cannot carry the required load can cause a voltage drop which can burn out the appliance or tool and overheat the cable. See Table 5.

- When connecting a resistance load such as an incandescent lamp or electric heater, a capacity of up to the generating set's rated output (kW) can be used.
- When connecting a fluorescent or mercury lamp, a capacity of up to the generating set's rated output (kW) multiplied by 0.6 can be used.
- When connecting an electric drill or other power tools, pay close attention to the required starting current capacity.

When connecting ordinary power tools, a capacity of up to the generating set's rated output (kW) multiplied by 0.8 can be used.

## CAUTION:



Before connecting this generator to any building's electrical system, a **licensed electrician** must install an **isolation (transfer) switch**. Serious injury or death may result without this transfer switch.

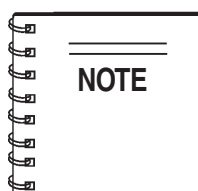

If 3Ø load (kVA) is not given on the equipment nameplate, approximate 3Ø load output may be determined by multiplying voltage by amperage by 1.732.

# DCA-70SSJU SERIES — GENERATOR OUTPUTS

## Generator Output Voltages

A wide range of voltages are available to supply voltage for many different applications. Voltages are selected by using the **voltage selector** switch (Figure 15). To obtain some of the voltages as listed in Table 6 (see below) will require a fine adjustment using the **voltage regulator (VR) control knob** located on the control panel.

## Voltage Selector Switch

The **voltage selector** switch (Figure 15) is located above the UVWO Hard Wire Hook-up Panel. It has been provided for ease of voltage selection.

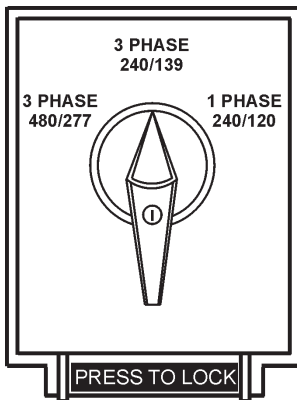

Figure 15. Voltage Selector Switch

## Voltage Selector Switch Locking Button

The voltage selector switch has a locking button to protect the generator and load from being switched while the engine is running. To lock the voltage selector switch, **press** and **hold** the **red button** located at the bottom of the switch.

## CAUTION:



**NEVER** change the position of the **voltage selector switch** while the engine is running. **ALWAYS** place circuit breaker in the open position before selecting voltage.

## Generator Amperage

Tables 7 and 8 describe the generator's current output capability for both 1Ø-phase and 3Ø phase applications.

Table 7. Generator Ampere Ratings — 1Ø

kW	240V	120V
20	83	166
25	104	208
30	225	250
35	145	291
40	166	333
45	187	375
50	208	417
60 (Max)	250	500

Table 8. Generator Ampere Ratings — 3Ø

kW	208V	240V	480V
20	59	60	30
25	87	75	38
30	104	90	45
35	121	105	53
40	139	120	60
45	156	136	68
50	174	152	76
60	208	181	99

Table 6. Voltages Available

	208 VOLT	220 VOLT	240 VOLT	416 VOLT	440 VOLT	480 VOLT
Three Phase (Switchable)						
Single Phase (Switchable)	120 VOLT	127 VOLT	139 VOLT	240 VOLT	254 VOLT	277 VOLT



# DCA-70SSJU SERIES — GENERATOR OUTPUTS/GAUGE READING

## GFCI Receptacle Load Capability

The load capability of the GFCI receptacles is directly related to the voltage being supplied at either the UVWO terminals or the 3 twist lock auxilliary receptacles.

Tables 9 and 10 show what amount of current is available at the GFCI receptacles when the UVWO terminals and twist lock receptacles are in use. Be careful that your load does not to exceed the available current capability at the receptacles.

**Table 9. GFCI Receptacle Load Capability**

KVA in Use (UVWO Terminals)	Available Load Current (AMPS)
3Ø 240/480V	GFCI Duplex NEMA 5-20R 120V
82	0
77.8	5 amps per receptacle
73.7	10 amps per receptacle
69.5	15 amps per receptacle
65.4	20 amps per receptacle

**Table 10. GFCI Receptacle Load Capability**

KW in Use Twist-Lock (CS6369)	Available Load Current (AMPS)
1Ø 240/120V	GFCI Duplex NEMA 5-20R 120V
60	0
58.8	5 amps per receptacle
57.6	10 amps per receptacle
56.4	15 amps per receptacle
55.2	20 amps per receptacle

## How to Read the Output Terminal Gauge.

The gauge and selector switch on the control panel **DO NOT** effect the generator output. They are provided to help observe how much power is being supplied, produced at the UVWO terminals lugs.

When the Voltage selector switch is in the 3Ø,240/139V position (See Figure 16), place the **AC Voltmeter Change-Over Switch** (Figure 17) to the W-U position and the **AC Ammeter Change-Over Switch** (Figure 19) to the U or W position to read the output on the selected leg.

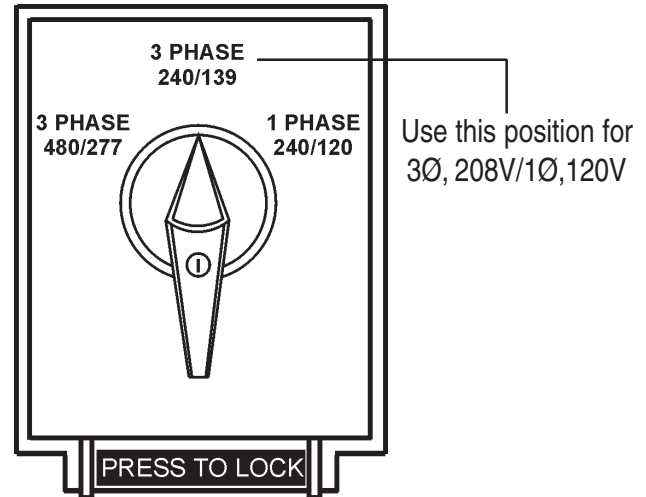

Figure 16. Voltage Selector Switch 240/139V Three Phase Position (for 3Ø, 208V, 120V voltage)

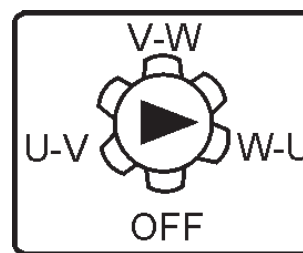

Figure 17. AC Voltmeter Change-Over Switch

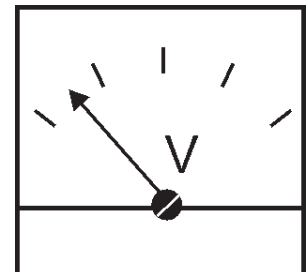

Figure 18 AC Voltmeter Gauge (Volt reading on W-U Lug)

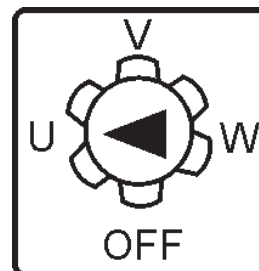

Figure 19. AC Ammeter Change-Over Switch

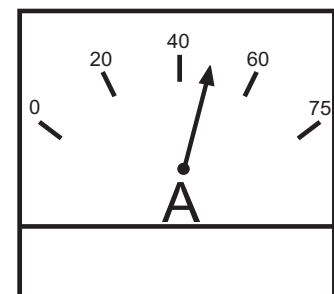
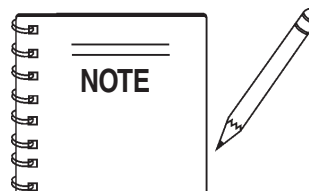

Figure 20. AC Ammeter Gauge (Amp reading on U lug)



The **ammeter** and **voltmeter** gauges are only active when the UVWO terminals are in use.

# DCA-70SSJU SERIES — OUTPUT TERMINAL PANEL CONNECTIONS

## UVWO Terminal Output Voltages

Various output voltages can be obtained using the UVWO output terminal lugs. The voltages at the terminals are dependent on the position of the **Voltage Selector Switch** and the adjustment of the **Voltage Regulator Control Knob**.

Remember the voltage selector switch determines the **range** of the output voltage. The voltage regulator (VR) allows the user to increase or decrease the selected voltage.

### 3Ø 240/139 UVWO Terminal Output Voltages

1. Place the voltage selector switch in the 3Ø 240/139 position as shown in Figure 21.

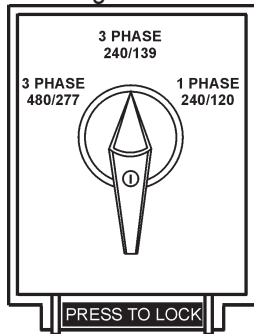

Figure 21. Voltage Selector Switch 240/139V Three-Phase Position

2. Connect the load wires to the UVWO terminals as shown in Figure 22.

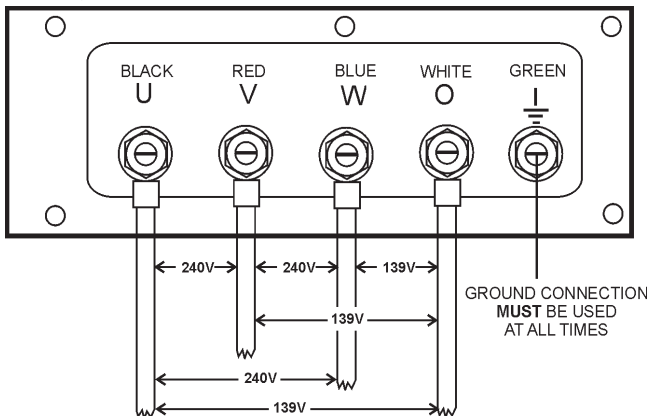

Figure 22. UVWO Terminal Lugs 240/139V Three Phase Connections

3. Turn the voltage regulator knob (Figure 23) clockwise to increase voltage output, turn counterclockwise to decrease voltage output.



Figure 23. Voltage Regulator Knob (139V/240V)

## 3Ø 208V/1Ø120V UVWO Terminal Output Voltages

1. Place the voltage selector switch in the 3Ø 240/139 position as shown in Figure 24.

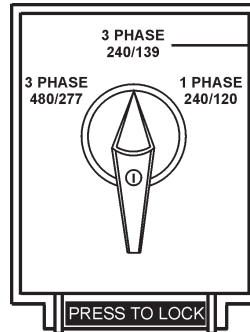

Use this position for 3Ø-208 or 1Ø120V.

Figure 24. Voltage Selector Switch 3Ø-208V/1Ø-120V Three-Phase Position

2. Connect the load wires to the UVWO terminals as shown in Figure 25.

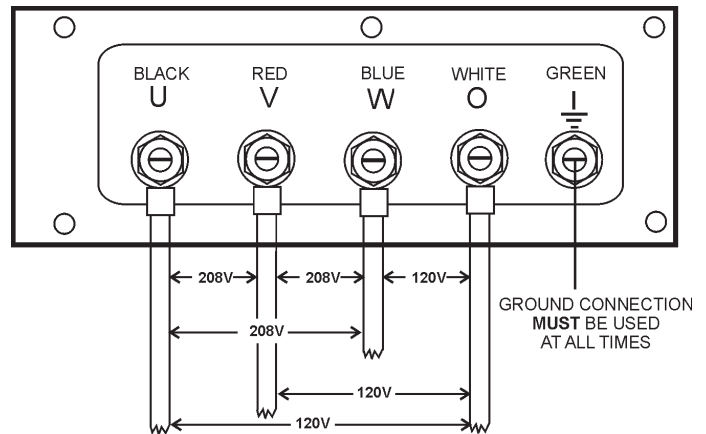
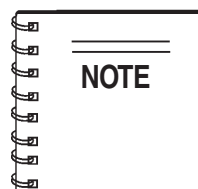

Figure 25. UVWO Terminal Lugs 3Ø-208V/120V Connections

3. Turn the voltage regulator knob (Figure 26) clockwise to increase voltage output, turn counterclockwise to decrease voltage output.



Figure 26. Voltage Regulator Knob (208V)



To achieve a 3Ø 208V output the voltage selector switch must be in the 3Ø-240/139 position and the voltage regulator must be adjusted to 208V.

# DCA-70SSJU SERIES — OUTPUT TERMINAL PANEL CONNECTIONS

## 3Ø 480/277 UVWO Terminal Output Voltages

1. Place the voltage selector switch in the 3Ø 480/277 position as shown in Figure 27.

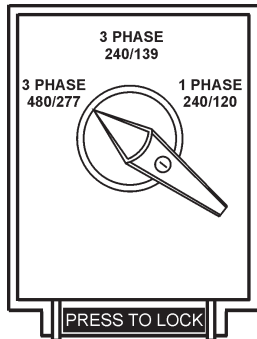

Figure 27. Voltage Selector Switch 480/277V Three-Phase Position

2. Connect the load wires to the UVWO terminals as shown in Figure 28.

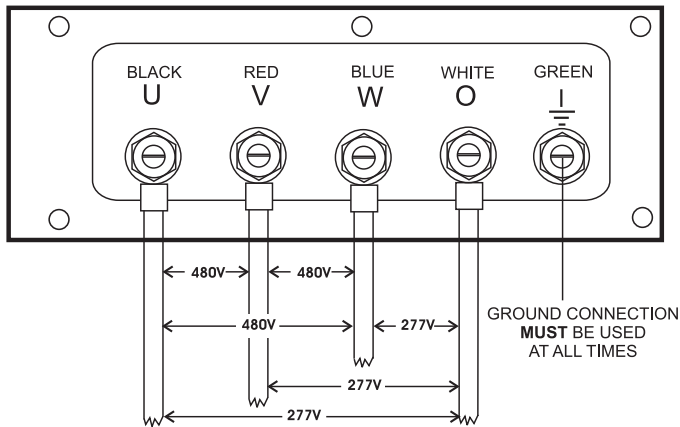

Figure 28. UVWO Terminal Lugs 240/139V Three Phase Connections

3. Turn the voltage regulator knob (Figure 29) clockwise to increase voltage output, turn counterclockwise to decrease voltage output.



Figure 29. Voltage Regulator Knob (139V/240V)

## 1Ø 240V/120V UVWO Terminal Output Voltages

1. Place the voltage selector switch in the 1Ø 240/120 position as shown in Figure 30.

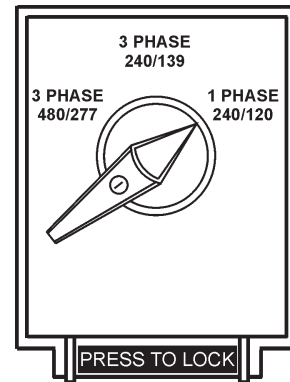

Figure 30. Voltage Selector Switch 240/120V Single-Phase Position

2. Connect the load wires to the UVWO terminals as shown in Figure 31.

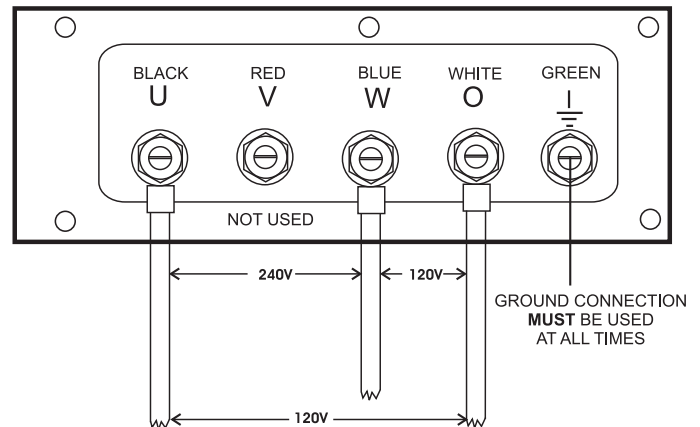

Figure 31. UVWO Terminal Lugs 1Ø-240V/120V Connections

3. Turn the voltage regulator knob (Figure 32) clockwise to increase voltage output, turn counterclockwise to decrease voltage output.



Figure 32. Voltage Regulator Knob (1Ø-240/120V)

## Circuit Breakers

To protect the generator from an overload, a 3-pole, 110 amp, **main** circuit breaker is provided to protect the UVW output terminals from overload. In addition two single-pole, 20 amp **GFCI** circuit breakers are provided to protect the GFCI receptacles from overload. Three 50 amp **load** circuit breakers have also been provided to protect the auxiliary receptacles from overload. Make sure to switch **ALL** circuit breakers to the "OFF" position prior to starting the engine.

## Lubrication Oil

Fill the engine crankcase with lubricating oil through the filler hole, but **DO NOT** overfill. Make sure the generator is level, and verify that the oil level is maintained between the two notches (Figure 33) on the dipstick. See Table 11 for proper selection of engine oil.

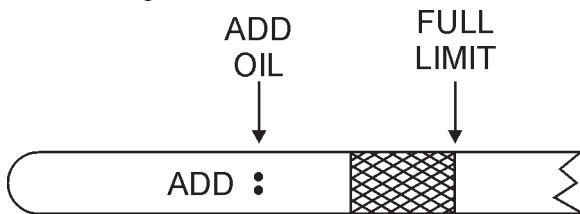

**Figure 33. Engine Oil Dipstick**

When checking the engine oil, be sure to check if the oil is clean. If the oil is not clean, drain the oil by removing the oil drain plug, and refill with the specified amount of oil as outlined in the **Isuzu Engine Owner's Manual**. Oil should be warm before draining.

Other types of motor oils may be substituted if they meet the following requirements:

- API Service Classification CH-4
- API Service Classification CG-4
- API Service Classification CF-4
- ACEA Specification E3
- ACEA Specification E2

**Table 11. Recommended Motor Oil**

Temperature Range	Type Oil
77°F and greater (25°C and greater)	SAE15W-40 or SAE40
32°F to 77°F (0°C to 25°C)	SAE 10W-30 or SAE30
-22°F to -32°F (-30°C to 0°C)	SAE10W-30 or SAE10

## Fuel Check

### DANGER:

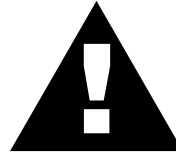

Fuel spillage on a **hot!** engine can cause a **fire** or **explosion**. If fuel spillage occurs, wipe up the spilled fuel completely to prevent fire hazards. **NEVER!** smoke around or near the generator.



## Refilling the Fuel System

The DCA70SSJU Series genset may (if equipped with a trailer or skid) have a **double fuel tank system** (Figure 34), which consists of an **internal** generator fuel tank, and a **trailer mounted** fuel tank. It is also possible the genset can be equipped with a **skid mounted** fuel tank (Figure 35). The skid type fuel system does not use the internal generator fuel tank.

Use the instructions in this section that applies to your type of fuel tank system.

**ALWAYS** fill the fuel tank with clean and fresh **#2 diesel fuel**. **DO NOT** fill the fuel tanks beyond their capacities.

Pay attention to the fuel tank capacity when replenishing fuel. The fuel tank cap must be closed tightly after filling. Handle fuel in a safety container. If the container does not have a spout, use a funnel. Wipe up any spilled fuel immediately.

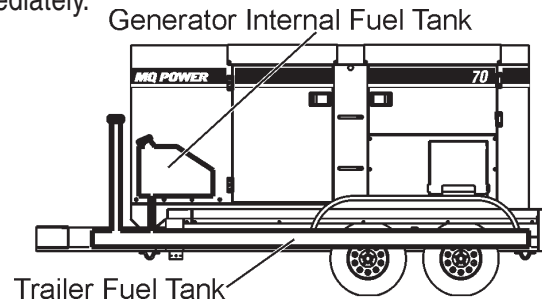

**Figure 34. Double Fuel Tank System**

### WARNING:



**ONLY** properly trained personnel who have read and understand this section should refill the double fuel tank system. Use **#2 diesel fuel**.

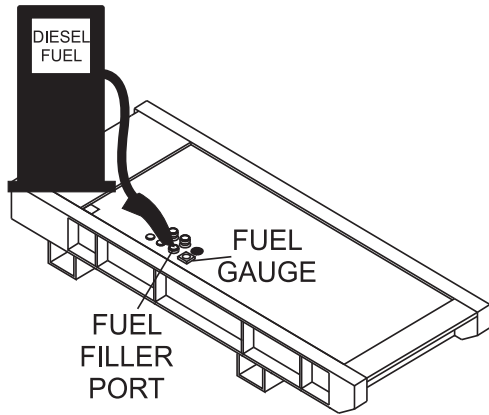

Figure 35. Skid Type Fuel Tank System

Refueling Procedure:

**DANGER:**



**Diesel fuel** and its vapors are dangerous to your health and the surrounding environment. Avoid skin contact and/or inhaling fumes.



1. **Level Tanks** – make sure fuel cells are level with the ground. Failure to do so will cause fuel to spill from the tank before reaching full capacity. See Figure 36.

**WARNING:**



**ALWAYS!** place trailer on firm level ground before refueling.

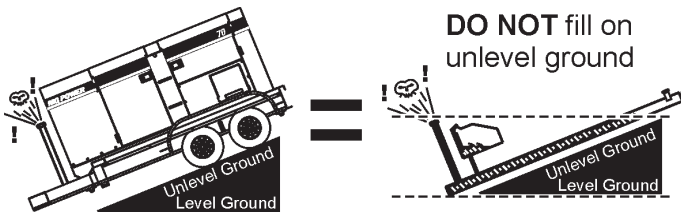

Figure 36. Only Fill on Level Ground

2. **Trailer Fuel Tank First** – The trailer fuel tank is the primary fuel tank and holds a larger capacity of fuel. The fuel in the trailer will be filtered and sent to the engine. **ALWAYS** fill trailer fuel tank (Figure 37) first.

**CAUTION:**



**ALWAYS!** fill trailer tank **first** with **#2 diesel fuel**, before filling secondary internal tank.

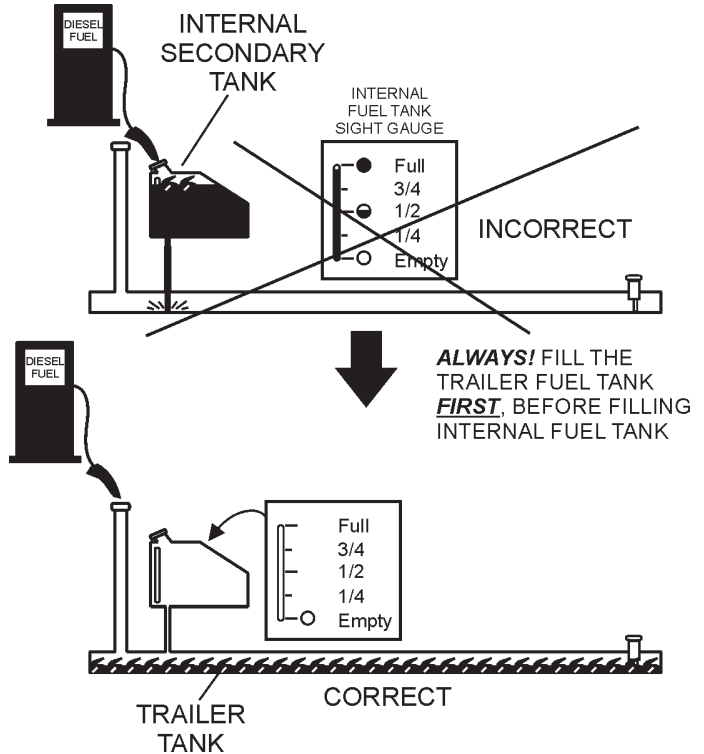
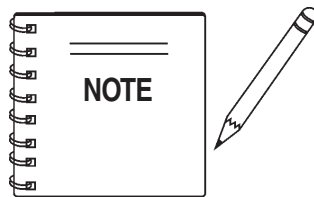
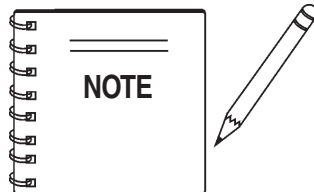

Figure 37. Fuel Tank Filling Order



**ONLY!** use **#2 diesel fuel** when refueling.



Fuel from the secondary inner tank will eventually drain into the primary trailer tank.

3. **NEVER overfill trailer fuel tank** – It is important to read the trailer fuel gauge when filling trailer fuel tank. **DO NOT** wait for fuel to rise in filler neck (See Figure 38).

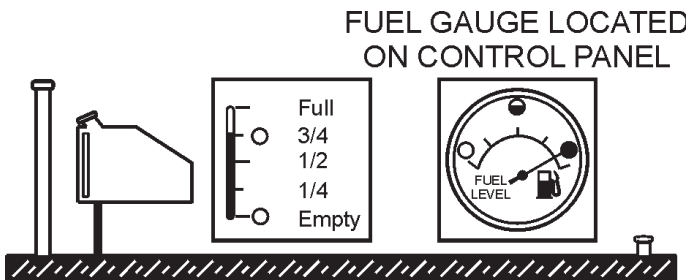

Figure 38. Full Trailer Tank

5. Figure 40 below reflects a full fuel system.

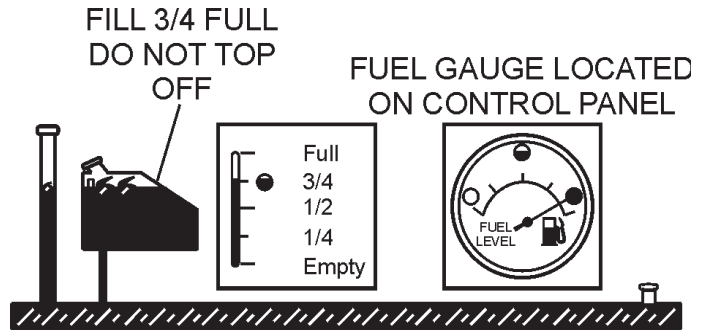

Figure 40. Full Fuel System

## WARNING:



**DO NOT OVER-FILL** fuel system. Leave room for fuel expansion. Fuel expands when heated.

4. Once the trailer tank is full, the **secondary inner tank** can be filled (See Figure 39). Notice how the trailer filler tube level rises when the internal tank is filled.

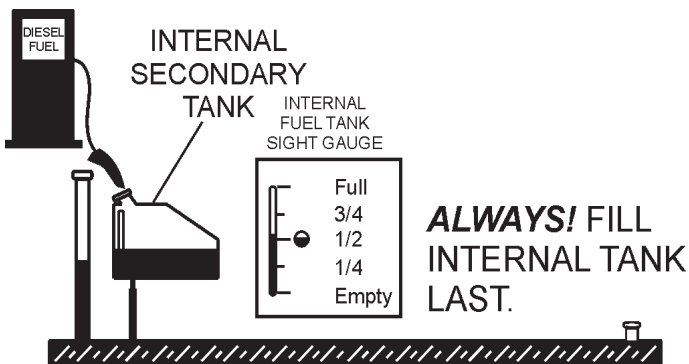

Figure 39. Filling Secondary Internal Fuel Tank

6. Fuel from the engine return line will drain into the secondary internal fuel tank. This fuel will eventually drain into the primary trailer tank in order to return to the engine.

## WARNING:



It is recommended to only fill the internal secondary tank to 3/4 full in order to allow for fuel return, fuel expansion, and to avoid spillage. See Figure 41 for fuel expansion.

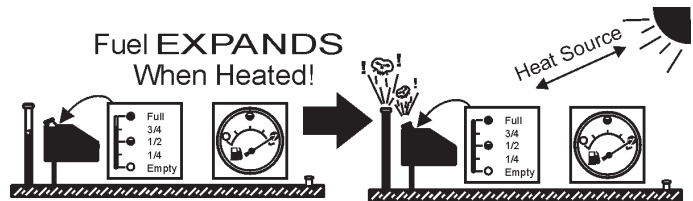

Figure 41. Fuel Expansion

## Coolant (Ethylene Glycol [Green] / Water — 50/50 mix)

Use only drinkable tap water. If hard water or water with many impurities is used, the inside of the engine and radiator may become coated with deposits and cooling efficiency will be reduced.

An anticorrosion additive added to the water will help prevent deposits and corrosion in the cooling system. See the engine manual for further details.

## CAUTION:



If adding coolant/antifreeze mix to the radiator, **DO NOT** remove the radiator cap until the unit has completely cooled. The possibility of **hot!** coolant exists which can cause severe burns.



Day-to-day addition of coolant is done from the recovery tank. When adding coolant to the radiator, **DO NOT** remove the radiator cap until the unit has completely cooled. See Table 12 for engine, radiator, and recovery tank coolant capacities. Make sure the coolant level in the recovery tank is always between the "H" and the "L" markings.

Day-to-day addition of coolant is done from the recovery tank. When adding coolant to the radiator, **DO NOT** remove the radiator cap until the unit has completely cooled. See Table 12 for engine, radiator, and recovery tank coolant capacities. Make sure the coolant level in the recovery tank is always between the "H" and the "L" markings.

Table 12. Coolant Capacity

Engine and Radiator	6.9 Gal. (26 liters)
Reserve Tank	2 Quarts (1.9 liters)

## Operation Freezing Weather

When operating in freezing weather, be certain the proper amount of antifreeze (Table 13) has been added.

Table 13. Anti-Freeze Operating Temperatures

Vol % Anti-Freeze	Freezing Point		Boiling Point	
	°C	°F	°C	°F
40	-24	-12	106	222
50	-37	-34	108	226

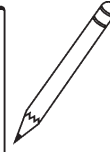
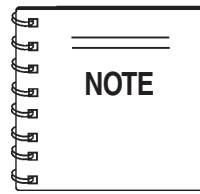

When the antifreeze is mixed with water, the antifreeze mixing ratio **must be** less than 50%.

## Cleaning the Radiator

The engine may overheat if the radiator fins become overloaded with dust or debris. Periodically clean the radiator fins with compressed air. Cleaning inside the machine is dangerous, so clean only with the engine turned off and the **negative** battery terminal disconnected.

## Air Cleaner

Periodic cleaning/replacement is necessary. Inspect it in accordance with the **Isuzu Engine Owner's Manual**.

## Fan Belt Tension

A slack fan belt may contribute to overheating, or to insufficient charging of the battery. Inspect the fan belt for damage and wear and adjust it in accordance with the **John Deere Engine Owner's Manual**.

The fan belt tension is proper if the fan belt bends 10 to 15 mm (Figure 42) when depressed with the thumb as shown below.

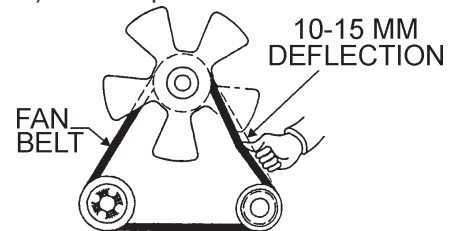

Figure 42. Fan Belt Tension

## CAUTION:



**NEVER!** place hands near the belts or fan while the generator set is running.



## Battery

This unit is of negative ground **DO NOT** connect in reverse. Always maintain battery fluid level between the specified marks. Battery life will be shortened, if the fluid level are not properly maintained. Add only distilled water when replenishment is necessary.

**DO NOT** over fill. Check to see whether the battery cables are loose. Poor contact may result in poor starting or malfunctions. **Always** keep the terminals firmly tightened. Coating the terminals with an approved battery terminal treatment compound. Replace battery with only recommended type battery. The battery type used in this generator is BCI Group 27.

The battery is sufficiently charged if the specific gravity of the battery fluid is 1.28 (at 68° F). If the specific gravity should fall to 1.245 or lower, it indicates that the battery is dead and needs to be recharged or replaced.

### Battery Cable Installation

**ALWAYS** be sure the battery cables (Figure 43) are properly connected to the battery terminals as shown below. The **RED** cable is connected to the positive terminal of the battery, and the **BLACK** cable is connected to the negative terminal of the battery.

### CAUTION:



**ALWAYS** disconnect the negative terminal **FIRST** and reconnect negative terminal **LAST**.

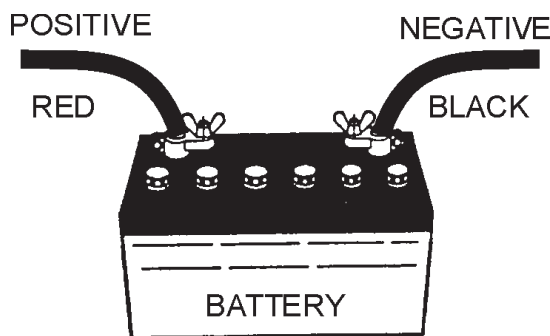
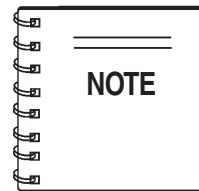

Figure 43. Battery Connections

When connecting battery do the following:

1. **NEVER** connect the battery cables to the battery terminals when the **ignition** switch is in either the **Pre-Heat, RUN, or START** position. **ALWAYS** make sure that the ignition switch is in the **STOP** position when connecting the battery.
2. Place a small amount of battery terminal treatment compound around both battery terminals. This will ensure a good connection and will help prevent corrosion around the battery terminals.



If the battery cable is connected incorrectly, electrical damage to the generator will occur. Pay close attention to the polarity of the battery when connecting the battery.

### CAUTION:



Inadequate battery connections may cause poor starting of the generator, and create other malfunctions.

### Alternator

The polarity of the alternator is negative grounding type. When an inverted circuit connection takes place, the circuit will be in short circuit instantaneously resulting the alternator failure.

**DO NOT** put water directly on the alternator. Entry of water into the alternator leads an electrolyte corrosion causing an alternator failure.

Before charging the battery with an external electric source, be sure to disconnect the battery cables.

### Wiring

Inspect the entire generator for bad or worn electrical wiring or connections. If any wiring or connections are exposed (insulation missing) replace wiring immediately.

### Piping and Hose Connection

Inspect all piping, oil hose, and fuel hose connections for wear and tightness. Tighten all hose clamps and check hoses for leaks.

If any hose (**fuel** or **oil**) lines are defective replace them immediately.



# DCA-70SSJU SERIES — GENERATOR START-UP PROCEDURE (MANUAL)

## WARNING:



The engine's exhaust contains harmful emissions. **ALWAYS have adequate ventilation when operating.** Direct exhaust away from nearby personnel.

### Before Starting

Engine Operating Panel S/N 73002140 and below

## CAUTION:



**NEVER!** manually start the engine with the **main, GFCI** or **auxiliary** circuit breakers in the **ON** (closed) position.

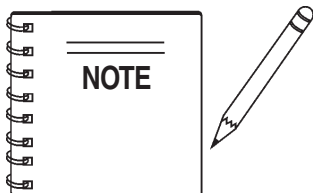

Steps 1 thru 19 are referenced for Engine Operating Panels up to S/N 73002140 (Figure 44). This unit has a ignition key switch and a throttle lever. It does not have an MPEC unit.

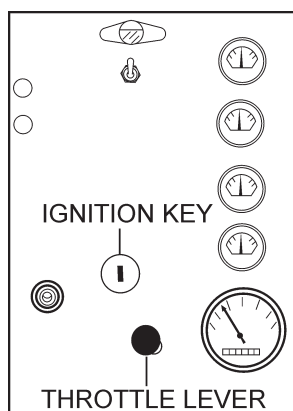

**Figure 44. Engine Operating Panel Up to S/N 73002140**

1. Place the **main, G.F.C.I.** and **aux.** circuit breakers (Figure 45) in the “OFF” position prior to starting the engine.

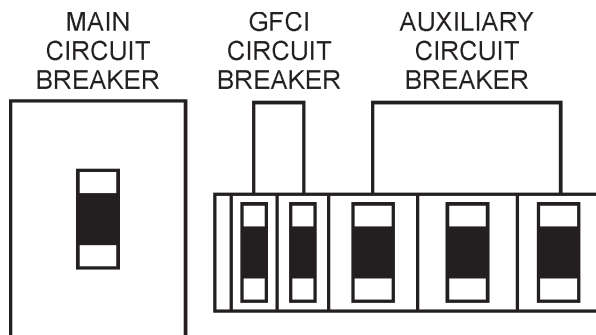

**Figure 45. Main, Aux. and GFCI Circuit Breakers (OFF)**

2. Connect the load to the **UVWO** terminals or **auxiliary receptacles** as shown in Figure 46. These load connection points can be found on the output terminal panel. To gain access to the UVWO terminals or other power receptacles, unlock the access cover and lift the door.
3. The UVWO terminals are protected by a plastic cover, remove this cover to gain access to the terminals. Tighten terminal nuts securely to prevent load wires from slipping out.

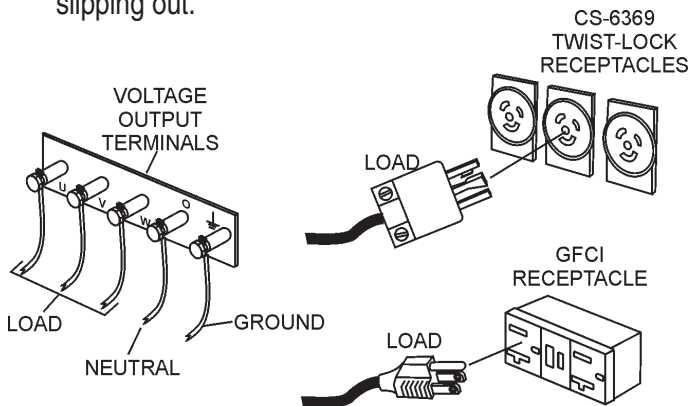

**Figure 46. Load Connections**

4. Close all engine enclosure doors (Figure 47).

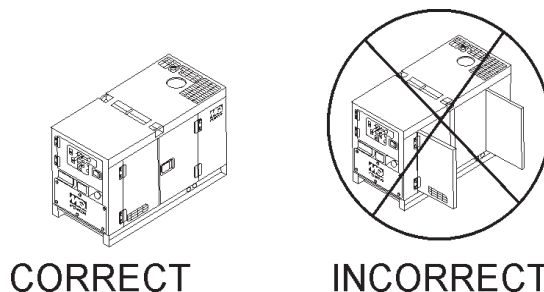

**Figure 47. Engine Enclosure Doors**

5. When starting the generator in **COLD** weather conditions, turn the **ignition key** to the “PREHEAT” position (Figure 48). In warm weather conditions, pre-heating is not necessary. Skip to step 7.

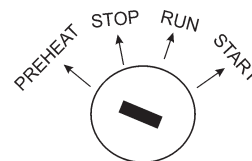

**Figure 48. Engine Ignition Switch (Pre-Heat)**

# DCA-70SSJU SERIES — GENERATOR START-UP PROCEDURE (MANUAL)

6. Press and hold the engine cold starting button (Figure 49) until the button illuminates (**ON**).



**Figure 49. Cold Starting Button**

7. Place the voltage selector switch in the desired voltage position (Figure 50).

**Figure 50. Voltage Selector Switch**

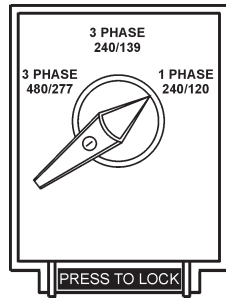

## STARTING (MANUAL)

Engine Operating Panel *up to S/N 73002140*

8. Place the **engine throttle control** in the “**LOW**” position (Figure 51).

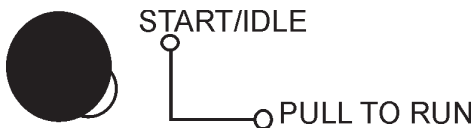

**Figure 51. Engine Throttle Control**

9. Turn the ignition key to the “**START**” position (Figure 52) and listen for the engine to begin cranking. After the engine starts release the ignition key.

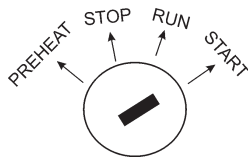

**Figure 52. Engine Ignition Switch (Start)**

10. Once the engine has started, let it run for 3-5 minutes, then turn the throttle handle control (Figure 53) to the “**HIGH**” position.

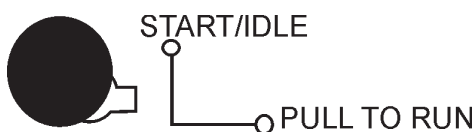

**Figure 53. Engine Throttle Control**

11. The generator's frequency meter (Figure 54) should be displaying the 60 cycle output frequency in **HERTZ**.

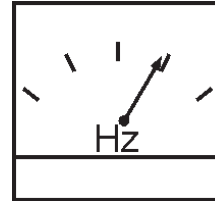

**Figure 54. Frequency Meter (Hz)**

12. The generator's AC-voltmeter (Figure 55) will display the generator's output in **VOLTS**. If the voltage is not within the specified tolerance, use the voltage adjustment control knob (Figure 56) to increase or decrease the desired voltage.

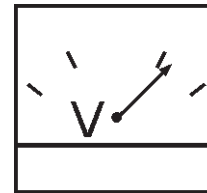

**Figure 55. Voltmeter**



**Figure 56. Voltage Adjust Control Knob**

9. Turn the ignition key to the “**START**” position (Figure 52) and listen for the engine to begin cranking. After the engine starts release the ignition key.

13. The ammeter (Figure 57) will indicate zero amps with no load applied. When a load is applied, the ammeter will indicate the amount of current that the load is drawing from the generator.

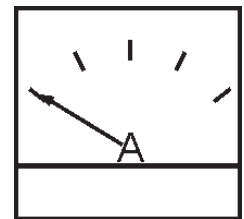

**Figure 57. Ammeter (No Load)**

10. Once the engine has started, let it run for 3-5 minutes, then turn the throttle handle control (Figure 53) to the “**HIGH**” position.

14. The engine oil pressure gauge (Figure 58) will indicate the oil pressure (kg/ cm<sup>2</sup>) of the engine. Under normal operating conditions the oil pressure is approximately

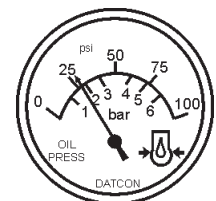

**Figure 58. Oil Pressure Gauge**

# DCA-70SSJU SERIES — GENERATOR START-UP PROCEDURE (MANUAL)

15. The **coolant temperature gauge** (Figure 59) will indicate the coolant temperature. Under normal operating conditions the coolant temperature should be between 165 and 215 degrees Fahrenheit (**Green Zone**).

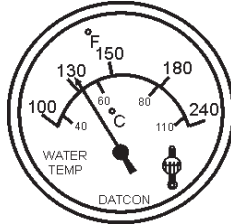

**Figure 59. Coolant Temperature Gauge**

16. The **tachometer gauge** (Figure 60) will indicate the speed of the engine when the generator is operating. Under normal operating conditions this speed is approximately 1800 RPM's.

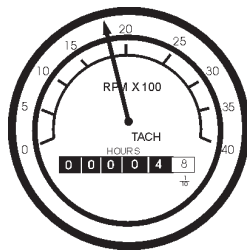

**Figure 60. Engine Tachometer Gauge**

17. Place the **main**, **GFCI**, and **aux.** circuit breakers in the "ON" position (Figure 61).

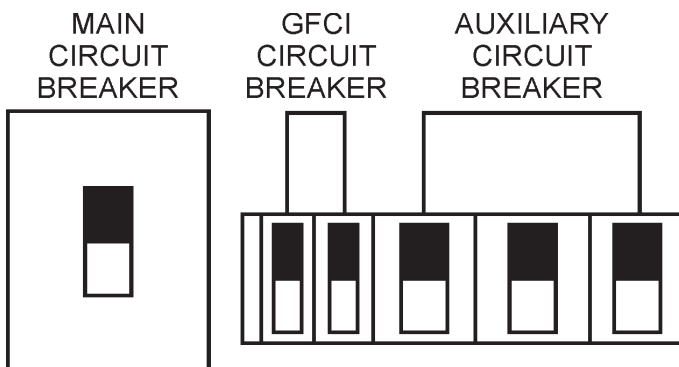

**Figure 61. Main, Aux. and GFCI Circuit Breakers (ON)**

18. Observe the generator's ammeter (Figure 62) and verify it reads the anticipated amount of current with respect to the load. The ammeter will only display a current reading if a load is in use.

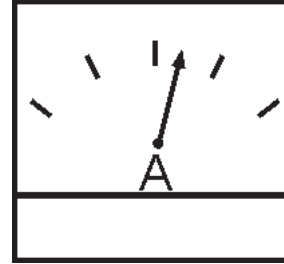

**Figure 62. Ammeter (Load)**

19. The generator will run until manually stopped or an abnormal condition occurs.

# DCA-70SSJU SERIES — GENERATOR START-UP PROCEDURE (MANUAL)

## WARNING:



The engine's exhaust contains harmful emissions. **ALWAYS have adequate ventilation when operating.** Direct exhaust away from nearby personnel.

### Before Starting

Engine Operating Panel S/N 73002141~

## CAUTION:



**NEVER!** manually start the engine with the **main, GFCI** or **auxiliary** circuit breakers in the **ON** (closed) position.

Steps 20 thru 31 are referenced for Engine Operating Panel S/N 73002141~ (Figure 63). This unit does **not** have a key ignition switch or a throttle lever. It does have an “**engine speed switch**” that is used in conjunction with the MPEC unit.

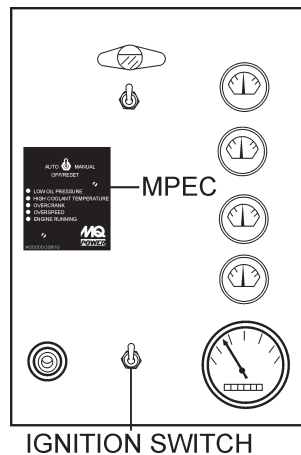
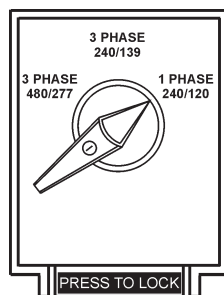

**Figure 63. Engine Operating Panel S/N 73002141~**

20. Perform steps 1 through 4 in the **Before Starting** section (page 41-42) as outlined in the **Manual Generator Start-up Procedure** (Engine Operating Panel up to S/N 73002140).
21. In cold weather conditions, perform step 6 in the **Before Starting** section (page 42) as outlined in the **Manual Generator Start-up Procedure** (Engine Operating Panel up to S/N 73002140). Otherwise skip to step 22.

22. Place the voltage selector switch in the desired voltage position (Figure 64).

**Figure 64. Voltage Selector Switch**



23. Set engine speed switch to “**LOW**” (Figure 65).

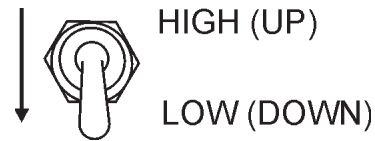

**Figure 65. Engine Speed Switch (Low)**

24. Place the Auto-Off/Reset-Manual switch in the “**MANUAL**” position to start the engine (Figure 66). Once the engine starts, let the engine run for 1-2 minutes. Listen for any abnormal noises.



**Figure 66. Auto-Off/Reset-Manual Switch**

25. Once the engine is warm and the engine is running properly, set the engine speed switch to “**HIGH**” (Figure 67).

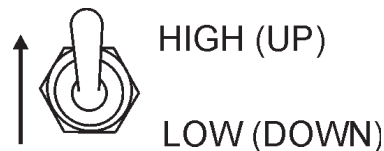

**Figure 67. Engine Speed Switch (High)**

26. Verify that the “**Engine Running**” status LED on the MPEC unit (Figure 68) is “**ON**” (lit) after the engine has been started.

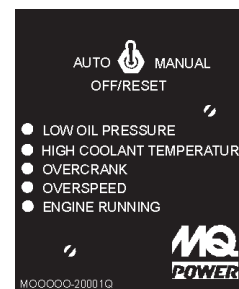

**Figure 68. Engine Running LED (ON)**

27. Continue operating the generator as outlined in steps 11 thru 19 (pages 42-43).

# DCA-70SSJU SERIES — GENERATOR START-UP PROCEDURE (AUTO MODE)

## DANGER:



Before connecting this generator to any building's electrical system, a **licensed electrician** must install an **isolation** (transfer)



**switch**. Serious **injury** or **death** may result without this transfer switch.

## CAUTION:



When connecting the generator to a isolation (transfer) switch, **ALWAYS** have power applied to the generator's internal battery charger. This will ensure that the engine will not fail due to a dead battery.

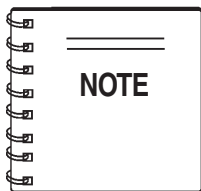

When the generator is set in the "AUTO" mode, the generator will **automatically start** in the event of commercial power falling below a prescribed level by means of a contact closure that is generated automatically by a transfer switch.

## WARNING:



When running the generator in the "AUTO" mode, remember the generator can start up at any time without warning. **NEVER** attempt to perform any maintenance when the generator is in the auto mode.

28. Perform steps 20 through 22 in the **Before Starting** section (pages 44) as outlined in the **Manual Starting Procedure**.

29. Set the engine speed switch (Figure 69) to the "HIGH" position.

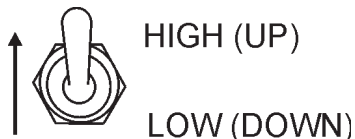

Figure 69. Engine Speed Switch (High)

## CAUTION:



The **Engine Speed Switch** **must** be set to the "HIGH" position when running in the **Auto-Start** mode. Failing to set the switch in the proper position can result in damage to your generator when it turns on.

30. Place the Off/Manual/Auto switch (Figure 70) in the "AUTO" position .



Figure 70. Off/Manual Auto Switch (AUTO)

31. Continue to follow the steps outlined in the "Manual Start-up" procedure (start at step 11, page 42).

# DCA-70SSJU SERIES — GENERATOR SHUT-DOWN PROCEDURE

## Shutdown Procedure - Ignition Switch (Up to S/N 73002140)

To shutdown the generator use the following procedure:

1. Place both the **MAIN**, **GFCI** and **LOAD** circuit breakers as shown in Figure 45 to the "OFF" position.
2. Place the **engine throttle control** in the "LOW" position (Figure 71).

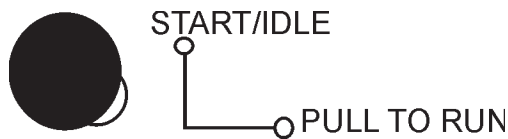

Figure 71. Engine Throttle Control (Low)

3. Let the engine cool by running it for 3-5 minutes with no load applied.
4. Turn the **Ignition Key Switch** (Figure 72) to the "OFF" position.

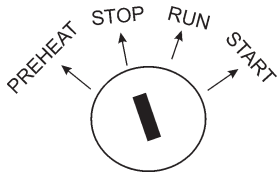

Figure 72. Engine Ignition Switch (Stop)

5. Remove all loads from the generator.

## Emergency Shutdown Procedure - Ignition Switch (Up to S/N 73002140)

1. To shut-down the engine in the event of an emergency, switch the **MAIN**, **GFCI** and **LOAD** (Figure 61) circuit breakers to "OFF" position.
2. Turn the **ignition switch key** to the "STOP" position (Figure 72).

## Shutdown Procedure - Engine Controller (S/N 73002141~)

To shutdown the generator use the following procedure:

1. Place both the **MAIN**, **GFCI** and **LOAD** circuit breakers as shown in Figure 45 to the "OFF" position.
2. Place the **engine speed switch** in the "LOW" position (Figure 73).



Figure 73. Engine Speed Switch (Low)

3. Let the engine cool by running it for 3-5 minutes with no load applied.
4. Place the **Auto-Off/Reset-Manual** switch (Figure 74) to the "OFF/Reset" position.



Figure 74. Off/Manual Auto Switch (Off)

5. Verify that the **all** status LED on the MPEC display (Figure 68) are "OFF" (not lit).
6. Remove all loads from the generator.

## Emergency Shutdown Procedure - Engine Controller (S/N 73002141~)

1. To shut-down the engine in the event of an emergency, switch the **MAIN**, **GFCI** and **LOAD** (Figure 45) circuit breakers to "OFF" position.
2. Place the **Auto-Off/Reset-Manual** switch (Figure 74) to the "OFF/Reset" position.

## CAUTION:



**NEVER** stop the engine suddenly except in an emergency. **DO NOT** use the emergency stop switch as a method of shutting down the generator. This switch is **ONLY** to be used in the event of an emergency.

TABLE 14. INSPECTION/MAINTENANCE		10 Hrs DAILY	250 Hrs	500 Hrs	1000 Hrs
<b>ENGINE</b>	Check Engine Fluid Levels	X			
	Check Air Cleaner	X			
	Check Battery Acid Level	X			
	Check Fan Belt Condition	X			
	Check for Leaks	X			
	Check for Loosening of Parts	X			
	Replace Engine Oil and Filter *1		X		
	Clean Air Filter		X		
	Drain Bottom of Fuel Tank		X		
	Clean Unit, Inside and Outside		X		
	Change Fuel Filter *2			X	
	Clean Radiator and Check Coolant Protection Level			X	
	Test Fuel Injection Nozzle			X	
	Replace Air Filter Element				X
	Check all Hoses and Clamps				X
	Check Valve Clearance				X
	Check Injection Nozzle			X	X
Clean Inside of Fuel Tank				X	
<b>GENERATOR</b>	Measure Insulation Resistance Over 3M ohms		X		

\*1 Replace engine oil and filter at 100 hours, first time only.

\*2 Replace fuel filter at 250 Hours, first time only.

## General Inspection

Prior to each use, the generator should be cleaned and inspected for deficiencies. Check for loose, missing or damaged nuts, bolts or other fasteners. Also check for fuel, oil, and coolant leaks.

## Engine Side (Refer to the Engine Instruction Manual)

### Air Cleaner

Every 50 hours: Remove air cleaner element and clean the heavy duty paper element with kerosene, or foam element with liquid detergent and hot water. Wrap foam element in a cloth and squeeze dry. For heavy duty paper element, wipe excess kerosene with towel.

### Air Cleaner with Dust Indicator

This indicator is attached to the air cleaner. When the air cleaner element is clogged, air intake restriction becomes greater and the dust indicator signal shows “**RED**” meaning the element needs changing. After changing the air element, press the dust indicator button to reset the indicator.

## Service Daily

If the engine is operating in very **dusty** or **dry grass** conditions, a clogged air cleaner will result. This can lead to a loss of power, excessive carbon buildup in the combustion chamber and high fuel consumption. Change air cleaner more **frequently** if these conditions exist.

## Fuel Addition

Add diesel fuel (the grade may vary according to season and locations). Always pour through the mesh filter.

## Removing Water from the Fuel Tank

After prolonged use, water and other impurities accumulate in the bottom of the tank. Occasionally remove the drain cock and drain the contents. During cold weather, the more empty volume inside the tank, the easier it is for water to condense. This can be reduced by keeping the tank full with diesel fuel.

## Air Removal

If air enters the fuel injection system of a diesel engine, starting becomes impossible. After running out of fuel, or after disassembling the fuel system, bleed the system according to the following procedure.

To restart after running out of fuel, turn the switch to the "ON" position for 15-30 seconds. Try again, if needed. This unit is equipped with an automatic air bleeding system.

## Cleaning the Fuel Strainer

Clean the fuel strainer if it contains dust or water. Remove dust or water in the strainer cap and wash it in gasoline. Securely fasten the fuel strainer cap so that fuel will not leak. Check the fuel strainer every 200 hours of operation or once a month.

## Check Oil Level

Check the crankcase oil level prior to each use, or when the fuel tank is filled. Insufficient oil may cause severe damage to the engine. Make sure the generator is level. The oil level must be between the two notches on the dipstick as shown in Figure 32.

## Replacing Oil Filter

- Detach the oil filter by loosening center bolt and remove the element together with the filter body.
- Apply a film of oil to the gasket for the cartridge.
- Install the filter body together with the element and fix them by tightening the center bolt.
- After the oil cartridge has been replaced, the engine oil will drop slightly. Run the engine for a while and check for leaks before adding more oil if needed. Clean excessive oil from engine.

## Replacing Fuel Filter

- Replace the fuel filter cartridge with new one every 400 hours or so.
- Loosen the drain plug at the lower top of the fuel filter. Drain the fuel in the fuel body together with the mixed water. **DO NOT** spill the fuel during disassembly.
- Vent any air.

## Feed Pump Strainer Cleaning

The strainer is incorporated in the feed pump inlet side joint bolt. Clean the strainer with compressed air and rinse it in the fuel oil.

## Flushing Out Radiator and Replacing Coolant

- Open both cocks located at the crankcase side and at the lower part of the radiator and drain coolant. Open the radiator cap while draining. Remove the overflow tank and drain.
- Check hoses for softening and kinks. Check clamps for signs of leakage.
- Flush the radiator by running clean tap water through radiator until signs of rust and dirt are removed. **DO NOT** clean radiator core with any objects, such as a screwdriver.
- Tighten both cocks and replace the overflow tank.
- Replace with coolant (Table 12 for correct mixture).
- Close radiator cap tightly.

## CAUTION:

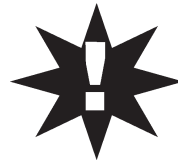

Allow engine to **cool** when flushing out radiator. Flushing the radiator while **hot!** will damage radiator.

## Generator Storage

For long term storage of the generator the following is recommended:

- Fill the fuel tank completely. Treat with a fuel stabilizer if necessary.
- Completely drain the oil from the crankcase and refill if necessary with fresh oil.
- Clean the entire generator, internal and external.
- Cover the generating set and store in a clean, dry place.
- Disconnect the battery.
- Make sure engine coolant is at proper level.
- If generator is mounted on a trailer, jack trailer up and place on block so tires do touch the ground or remove tires.



## Jacket Water Heater and Internal Battery Charger 120 VAC Input Receptacles (OPTIONAL)

This generator is equipped with two 120 VAC, 20 amp input receptacles located on the output terminal panel.

The purpose of these receptacles is to provide power via commercial power to the *jacket water heater* and *internal battery charger*.

These receptacles will **ONLY** function when commercial power has been supplied to them (Figure 75). To apply commercial power to these receptacles, a power cord of adequate size will be required (See Table 5).

When using the generator in *hot* climates there is no reason to apply power to jacket water heater. However, if the generator will be used in *cold* climates it is always a good idea to apply power to the jacket water heater at all times. To apply power to the jacket water heater simply apply power to the jacket water heater receptacle via commercial power using a power cord of adequate size.

If the generator will be used daily, the battery should normally not require charging. If the generator will be idle (not used) for long periods of time, apply power to the battery charger receptacle via commercial power using a power cord of adequate size.

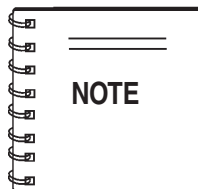

To ensure adequate starting capability, **always** have power applied to the generator's *internal battery charger*.

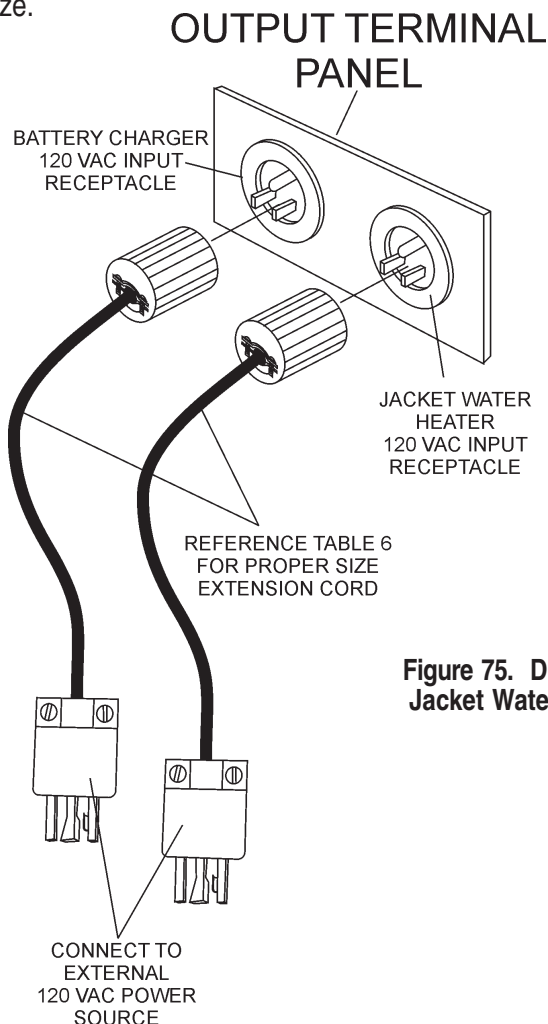

Figure 75. DCA-45SIU2 Battery Charger & Jacket Water Heater Power Connections

# DCA-70SSJU SERIES — TRAILER BRAKES MAINTENANCE

## Brakes

Trailer brakes should be inspected the **first 200 miles** of operation. This will allow the brake shoes and drums to seat properly. After the first 200 mile interval, inspect the brakes **every 3,000 miles**. If driving over rough terrain, inspect the brakes more frequently.

Figure 74 displays the major hydraulic surge brake components that will require inspection and maintenance. Please inspect these components as required using steps 1 through 8 as listed below:

### Brake Adjustment

1. Place the trailer on jack stands. Make sure the jack stands are placed on secure level ground.
2. Check the wheel and drum for free rotation.
3. Remove the adjusting hole cover from the adjusting slot at the bottom brake backing plate.
4. With a screwdriver or standard adjusting tool, rotate the star wheel of the adjuster assembly to expand the brake shoes.
5. Adjust the brake shoes outward until the pressure of the lining against the wheel drum makes the wheel difficult to turn.
6. Adjust, rotate the star wheel in the opposite direction until the wheel rotates freely with slight lining drag.
7. Replace the adjusting hole cover and lower the trailer to the ground.
8. Repeat steps 1 through 7 on the remaining brakes.

## Hydraulic Surge Brakes

Hydraulic surge brakes (Figure 76) should not require any special attention with the exception of routine maintenance such as shoe and lining replacement. Brake lines should be periodically checked for cracks, kinks, or blockage.

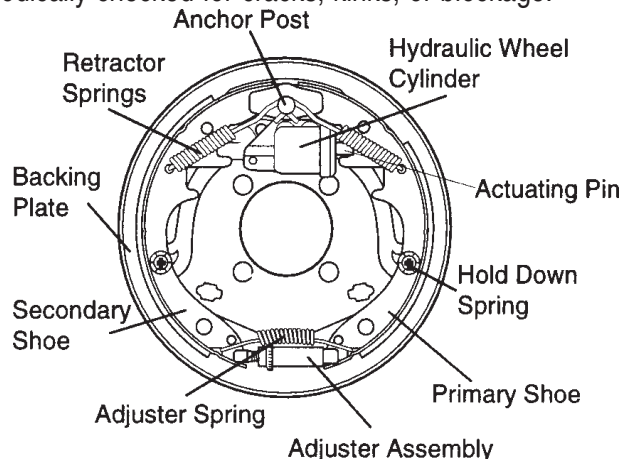

**Figure 76. Hydraulic Brake Components**

### Actuator

Hydraulic surge braking requires the installation of an actuator at the tongue of the trailer. Remember the **surge** or **push** of the trailer toward the tow vehicle automatically synchronizes the trailer brakes with the tow vehicle brakes. As the trailer pushes against the tow vehicle the actuator telescopes together and applies force to the master cylinder, supplying hydraulic pressure to the trailer brakes.

Periodically check and test the surge **“actuator”** to make sure that it is functioning correctly. Never use an undersize actuator.

**Table 15. Hydraulic Brake Troubleshooting**

Symptom	Possible Cause	Solution
No Brakes	Brake line broken or kinked?	Repair or replace.
Weak Brakes or Brakes Pull to One Side	Brake lining glazed?	Reburnish or replace.
	Trailer overloaded?	Correct weight.
	Brake drums scored or grooved?	Machine or replace.
	Tire pressure correct?	Inflate all tires equally.
	Tires unmatched on the same axle?	Match tires.
Locking Brakes	Brake components loose, bent or broken?	Replace components.
	Brake drums out-of-round?	Replace.
Noisy Brakes	System lubricated?	Lubricate.
	Brake components correct?	Replace and correct.
Dragging Brakes	Brake lining thickness incorrect or not adjusted correctly?	Install new shoes and linings.
	Enough brake fluid or correct fluid?	Replace rubber parts fill with dot 4 fluid.

# DCA-70SSJU SERIES — TRAILER MAINTENANCE

## Tires/Wheels/Lug Nuts

Tires and wheels are a very important and critical components of the trailer. When specifying or replacing the trailer wheels it is important the wheels, tires, and axle are properly matched.

### CAUTION:



**DO NOT** attempt to repair or modify a wheel. **DO NOT** install in inner tube to correct a leak through the rim. If the rim is cracked, the air pressure in the inner tube may cause pieces of the rim to explode (break off) with great force and cause serious eye or bodily injury.

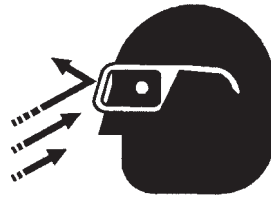

## Tire Wear/Inflation

Tire inflation pressure is the most important factor in tire life. Pressure should be checked cold before operation **DO NOT** bleed air from tires when they are *hot!* Check inflation pressure weekly during use to insure the maximum tire life and tread wear.

Table 16 (Tire Wear Troubleshooting) will help pinpoint the causes and solutions of tire wear problems.

TABLE 16. TIRE WEAR TROUBLESHOOTING		
WEAR PATTERN	CAUSE	SOLUTION
Center Wear	Over Inflation.	Adjust pressure to particular load per tire manufacturer.
Edge Wear	Under Inflation.	Adjust pressure to particular load per tire manufacturer.
Side Wear	Loss of camber or overloading.	Make sure load does not exceed axle rating. Align wheels.
Toe Wear	Incorrect toe-in.	Align wheels.
Cupping	Out-of-balance.	Check bearing adjustment and balance tires.
Flat Spots	Wheel lockup & tire skidding.	Avoid sudden stops when possible and adjust brakes.

## Suspension

The *leaf suspension* springs and associated components (Figure 77) should be visually inspected every 6,000 miles for signs of excessive wear, elongation of bolt holes, and loosening of fasteners. Replace all damaged parts (suspension) immediately. Torqued suspension components as detailed in Table 17.

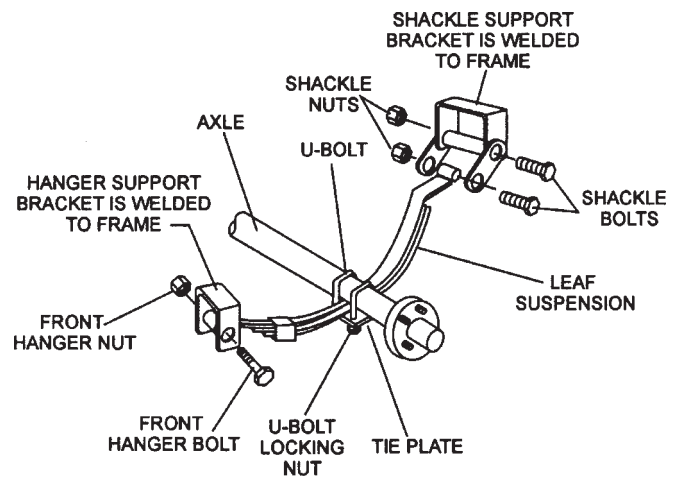

Figure 77. Major Suspension Components

Table 17. Suspension Torque Requirements

Item	Torque (Ft.-Lbs.)
3/8" U-BOLT	MIN-30 MAX-35
7/16" U-BOLT	MIN-45 MAX-60
1/2" U-BOLT	MIN-45 MAX-60
SHACKLE BOLT SPRING EYE BOLT	SNUG FIT ONLY. PARTS MUST ROTATE FREELY. LOCKING NUTS OR COTTER PINS ARE PROVIDED TO RETAIN NUT-BOLT ASSEMBLY.
SHOULDER TYPE SHACKLE BOLT	MIN-30 MAX-50

### CAUTION:



**ALWAYS** wear safety glasses when removing or installing force fitted parts. Failure to comply may result in serious injury.

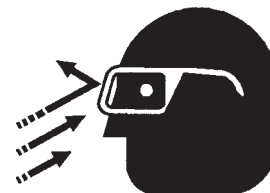

# DCA-70SSJU SERIES — TRAILER MAINTENANCE

## Lug Nut Torque Requirements

It is extremely important to apply and maintain proper wheel mounting torque on the trailer. Be sure to use only the fasteners matched to the cone angle of the wheel. Proper procedure for attachment of the wheels is as follows:

1. Start all wheel lug nuts by hand.
2. Torque all lug nuts in sequence (see Figure 78). **DO NOT** torque the wheel lug nuts all the way down. Tighten each lug nut in 3 separate passes as defined by Table 18.
3. After first road use, retorque all lug nuts in sequence. Check all wheel lug nuts periodically.

Table 18. Tire Torque Requirements

Wheel Size	First Pass FT-LBS	Second Pass FT-LBS	Third Pass FT-LBS
12"	20-25	35-40	50-65
13"	20-25	35-40	50-65
14"	20-25	50-60	90-120
15"	20-25	50-60	90-120
16"	20-25	50-60	90-120

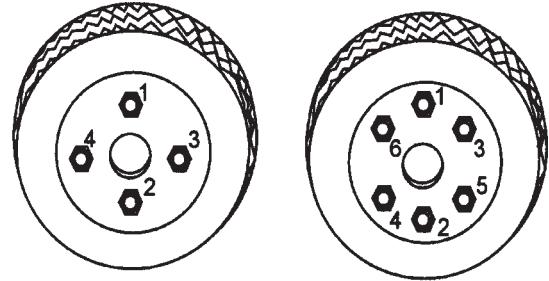

4-LUG NUTS

6-LUG NUTS

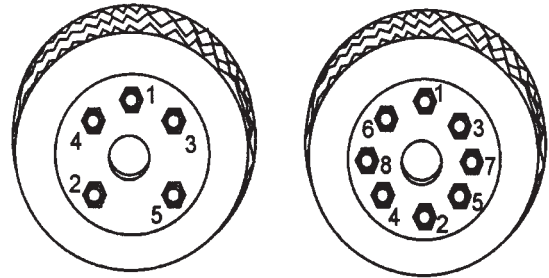

5-LUG NUTS

8-LUG NUTS

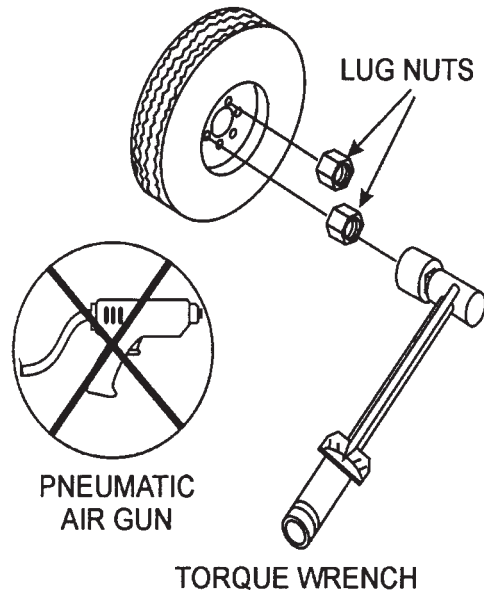
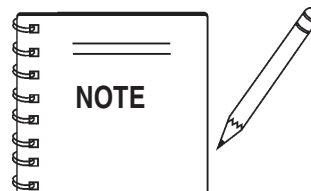

Figure 78. Wheel Lug Nuts Tightening Sequence



**NEVER** use an pneumatic air gun to tighten wheel lug nuts.

# DCA-70SSJU SERIES — TRAILER WIRING DIAGRAM

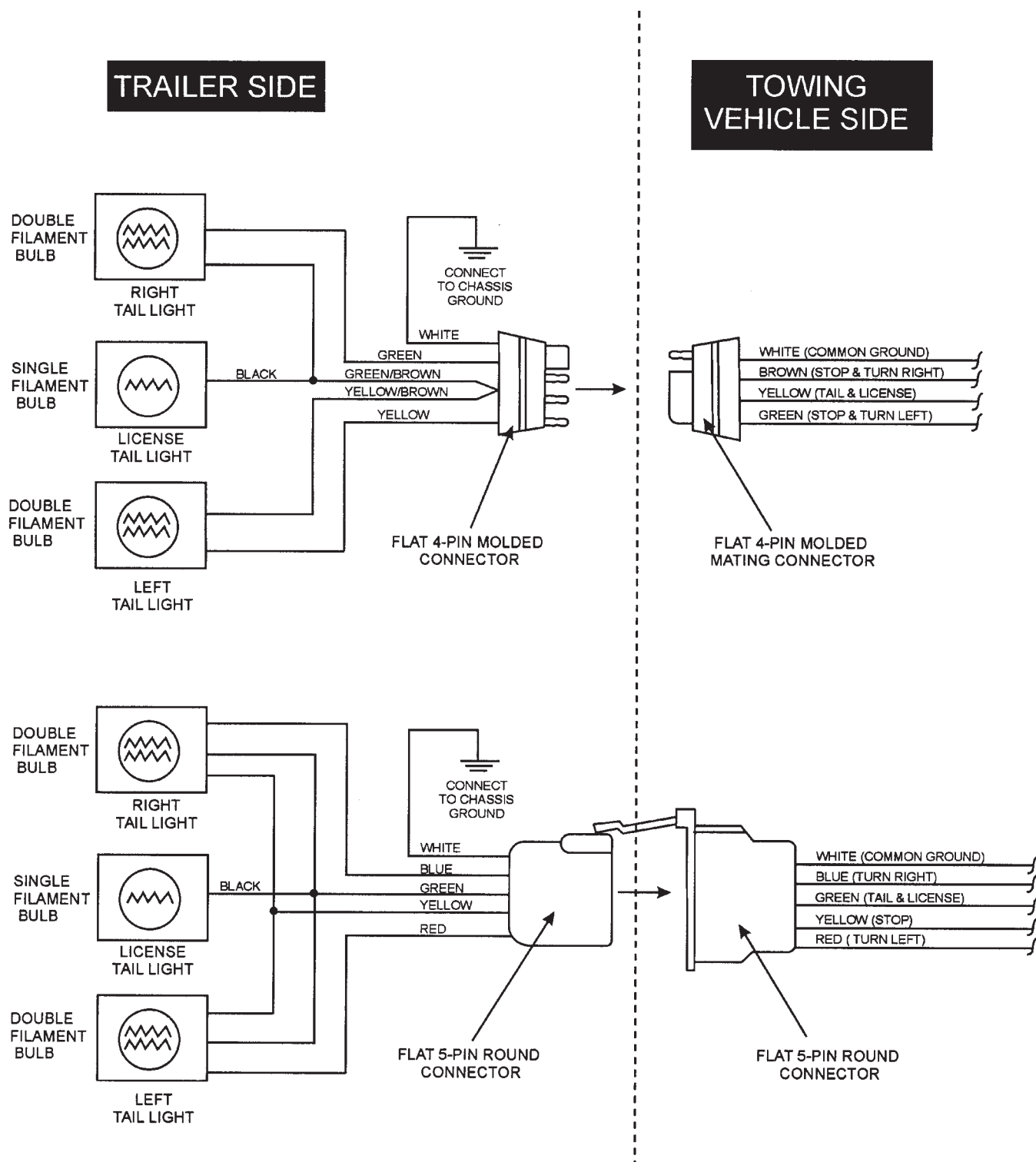
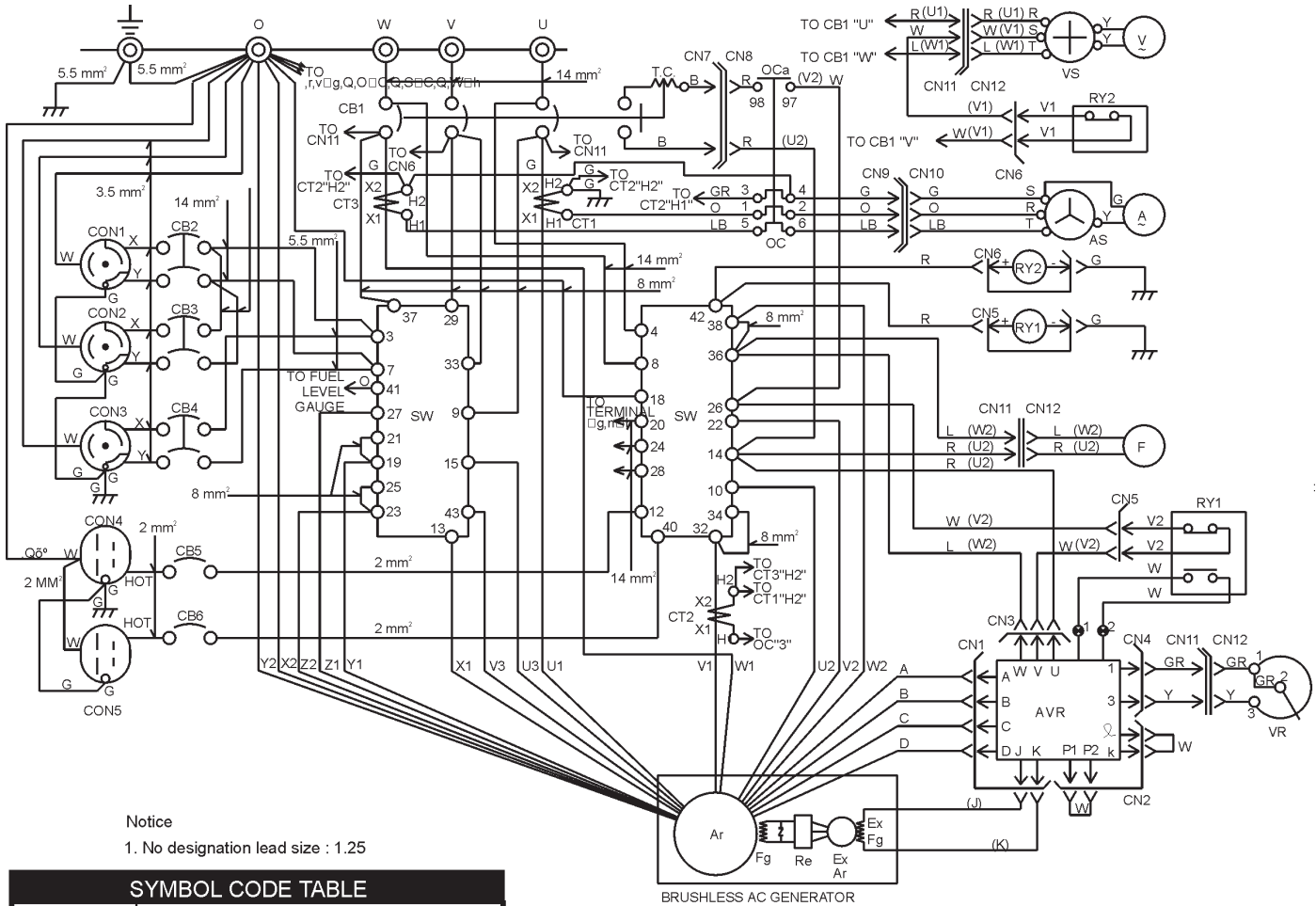

Figure 79. Trailer/Towing Vehicle Wiring Diagram

# DCA-70SSJU SERIES — GENERATOR WIRING DIAGRAM



Notice  
1. No designation lead size : 1.25

## SYMBOL CODE TABLE

SYMBOL	DESIGNATION
Ar	MAIN GENERATOR ARMATURE WINDING
Fg	MAIN GENERATOR FIELD WINDING
ExAr	EXCITER ARMATURE WINDING
ExFg	EXCITER FIELD WINDING
Re	RECTIFIER
AVR	AUTOMATIC VOLTAGE REGULATOR
VR	VOLTAGE REGULATOR (RHEOSTAT)
CT 1,2,3	CURRENT TRANSFORMER
AS	CHANGE-OVER SWITCH, AMMETER
A	AC. AMMETER
VS	CHANGE-OVER SWITCH, VOLTMETER
V	AC. VOLTMETER
F	FREQUENCY METER
Cb1	CIRCUIT BREAKER
CB 2,3,4	CIRCUIT BREAKER
CB 5,6	CIRCUIT BREAKER
CON 1,2,3	RECEPTACLE
CON 4,5	RECEPTACLE
OC	OVER CURRENT RELAY
SW	SELECTOR SWITCH
RY1,2	RELAY UNIT

## COLOR CODE TABLE

CODE/ WIRE COLOR			
B	BLACK	R	RED
L	BLUE	W	WHITE
BR	BROWN	Y	YELLOW
G	GREEN	LB	LIGHT BLUE
GR	GRAY	LG	LIGHT GREEN
V	VIOLET	O	ORANGE
P	PINK		

Figure 80. Generator Wiring Diagram

## CONNECTOR ARRANGEMENT

## (WIRING VIEW)

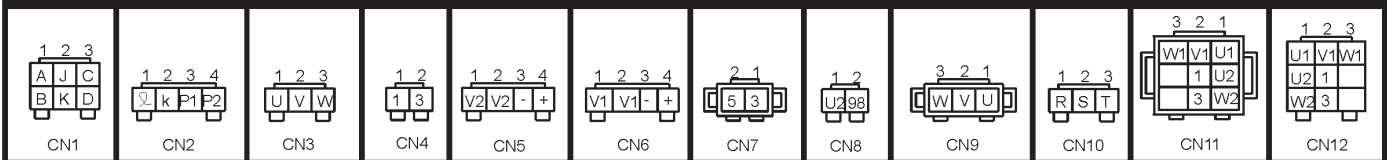

# DCA-70SSJU SERIES — ENGINE WIRING DIAGRAM (WITH CONTROLLER)

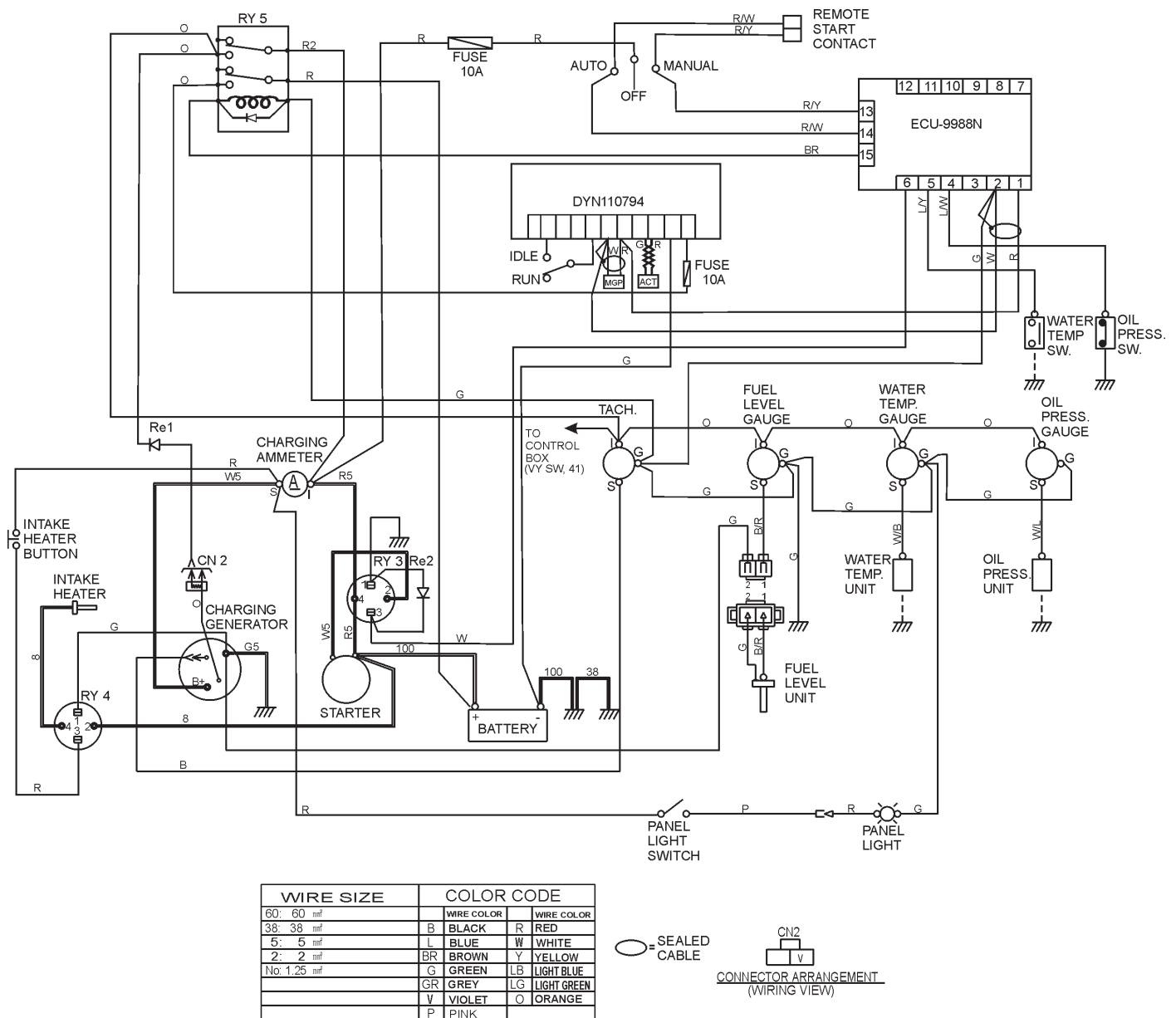

Figure 81. Engine Wiring Diagram (Controller)

# DCA-70SSJU SERIES — ENGINE WIRING DIAGRAM (WITH IGNITION SWITCH)

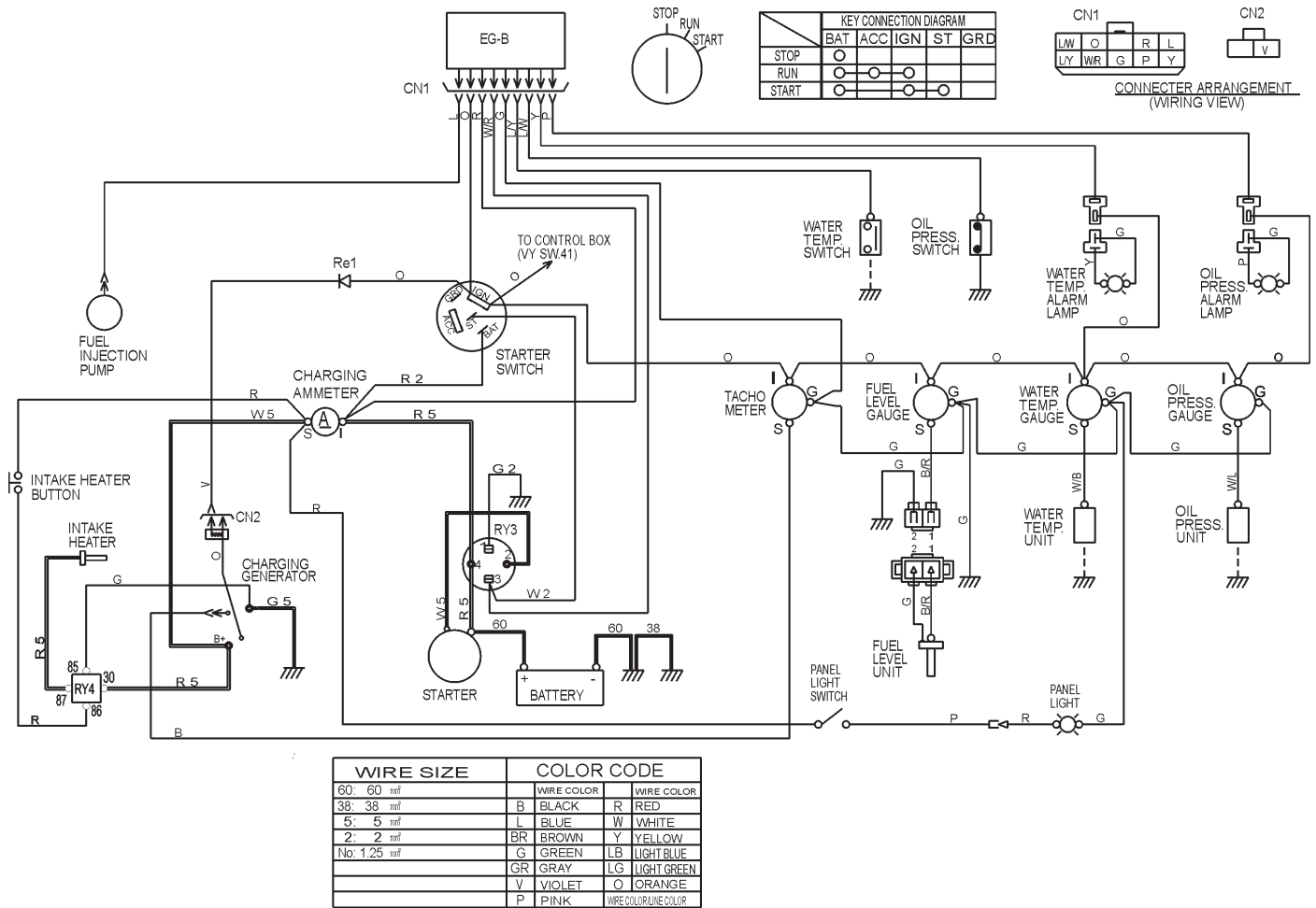

Figure 82. Engine Wiring Diagram (with Ignition Switch)



## DCA-70SSJU SERIES — TROUBLESHOOTING (ENGINE)

Practically all breakdowns can be prevented by proper handling and maintenance inspections, but in the event of a breakdown, use the tables shown for diagnosis based on the Engine Troubleshooting (Table 19). If the problem cannot be remedied, consult our company's business office or service plant.

### TABLE 19. ENGINE TROUBLESHOOTING

SYMPTOM	POSSIBLE PROBLEM	SOLUTION
Engine does not start.	No fuel?	Replenish fuel.
	Air in the fuel system?	Bleed system.
	Water in the fuel system?	Remove water from fuel tank.
	Fuel pipe clogged?	Clean fuel pipe.
	Fuel filter clogged?	Clean or change fuel filter.
	Excessively high viscosity of fuel or engine oil at low temperature?	Use the specified fuel or engine oil.
	Fuel with low cetane number?	Use the specified fuel.
	Fuel leak due to loose injection pipe retaining nut?	Tighten nut.
	Incorrect injection timing?	Adjust.
	Fuel cam shaft worn?	Replace.
	Injection nozzle clogged?	Clean injection nozzle.
	Injection pump malfunctioning?	Repair or replace.
	Seizure of crankshaft, camshaft, piston, cylinder liner or bearing?	Repair or replace.
	Compression leak from cylinder?	Replace head gasket, tighten cylinder head bolt, glow plug and nozzle holder.
	Improper valve timing?	Correct or replace timing gear.
	Piston ring and liner worn?	Replace.
Excessive valve clearance?	Adjust.	
Starter does not run.	Starter malfunctioning?	Repair or replace.
	Wiring disconnected?	Connect wiring.

# DCA-70SSJU SERIES — TROUBLESHOOTING (ENGINE)

## TABLE 19. ENGINE TROUBLESHOOTING (CONTINUED)

SYMPTOM	POSSIBLE PROBLEM	SOLUTION
Engine revolution is not smooth.	Fuel filter clogged or dirty?	Clean or change.
	Air cleaner clogged?	Clean or change.
	Fuel leak due to loose injection pipe retaining nut?	Tighten nut.
	Injection pump malfunctioning?	Repair or replace.
	Incorrect nozzle opening pressure?	Adjust.
	Injection nozzle stuck or clogged?	Repair or replace.
	Fuel over flow pipe clogged?	Clean.
	Governor malfunctioning?	Repair.
Either white or blue exhaust gas is observed.	Excessive engine oil?	Reduce to the specified level.
	Piston ring and liner worn or stuck?	Repair or replace.
	Incorrect injection timing?	Adjust.
	Deficient compression?	Adjust top clearance.
Either black or dark gray exhaust gas is observed.	Overload?	Lessen the load.
	Low grade fuel used?	Use the specified fuel.
	Fuel filter clogged?	Clean or change.
	Air cleaner clogged?	Clean or change.
	Deficient nozzle injection?	Repair or replace the nozzle.
Deficient output.	Incorrect injection timing?	Adjust.
	Engine's moving parts seem to be seizing?	Repair or replace.
	Uneven fuel injection?	Repair or replace the injection pump.
	Deficient nozzle injection?	Repair or replace the nozzle.
	Compression leak?	Replace head gasket, tighten cylinder head bolt, glow plug and nozzle holder.

## DCA-70SSJU SERIES — TROUBLESHOOTING (GENERATOR)

Practically all breakdowns can be prevented by proper handling and maintenance inspections, but in the event of a breakdown, use the tables shown for diagnosis based on the Engine and Radiator Troubleshooting (Table 20) . If the problem cannot be remedied, consult our company's business office or service plant.

**TABLE 20. GENERATOR TROUBLESHOOTING**

SYMPTOM	POSSIBLE PROBLEM	SOLUTION
No Voltage Output	AC Voltmeter defective?	Check output voltage using a voltmeter.
	Is wiring connection loose?	Check wiring and repair.
	Is AVR defective?	Replace if necessary.
	Defective Rotating Rectifier?	Check and replace.
Low Voltage Output	Is engine speed correct?	Turn engine throttle lever to "High".
	Is wiring connections loose?	Check wiring and repair.
	Defective AVR?	Replace if necessary.
High Voltage Output	Is wiring connections loose?	Check wiring and repair.
	Defective AVR?	Replace if necessary.
Circuit Breaker Tripped	Short Circuit in load?	Check load and repair.
	Over current?	Confirm load requirements and reduce.
	Defective circuit breaker?	Check and replace.
	Over current Relay actuated?	Confirm load requirement and replace.

# DCA-70SSJU SERIES — TROUBLESHOOTING (ENGINE CONTROLLER)

Practically all breakdowns can be prevented by proper handling and maintenance inspections, but in the event of a breakdown, use Table 21 (Engine Controller Troubleshooting) as a basic guideline for troubleshooting the Microprocessor Engine Controller unit (MPEC). If the problem cannot be remedied, consult our company's business office or service plant.

**TABLE 21. ENGINE CONTROLLER TROUBLESHOOTING (MPEC)**

Sympton	Possible Cause	Solution
Low oil pressure light is on.	Low oil level?	Fill oil level.
	Oil pressure sending unit failure?	Replace oil pressure sending unit.
	Time delay malfunction in Controller?	Refer to dealer.
	Wire shorted?	Inspect/repair wire.
Low coolant level light is on.	Low coolant level?	Fill coolant level.
	Sending unit failure?	Replace sending unit.
	Low battery voltage?	Replace/charge battery.
High coolant temperture light is on.	Fan belt tension incorrect?	Tighten/replace fan belt.
	Air flow is not circulation through radiator?	Clean/repair radiator grill.
	Doors open?	Close doors.
	Exhaust leaking?	Replace/repair gaskets or faulty part.
	Generator being overloaded?	Check/reduce load.
	Thermostat failure?	Replace thermostat.
	Air intake blocked?	Clear all air intakes.
	Temperature switch failure?	Replace temperature switch.
Overcrank light is on.	No or low Fuel?	Fill fuel level.
	Controller needs to be calibrated?	Refer to dealer.
Overspeed light is on.	RPM engine speed too high?	Adjust RPM.
	Governor actuator needs to be adjusted?	Adjust governor actuator.
	Governor controller needs to be adjusted?	Adjust governor controller.
	Engine Controller needs to be calibrated?	Refer to dealer.
Loss of MPU light(s) or on.	Magnetic pick up out of adjustment?	Adjust magnetic pick up.
	Magnetic pick up dirty?	Clean magnetic pick up.



# EXPLANATION OF CODE IN REMARKS COLUMN

How to read the marks and remarks used in this parts book.

## Items Found In the “Remarks” Column

Serial Numbers-Where indicated, this indicates a serial number range (inclusive) where a particular part is used.

Model Number-Where indicated, this shows that the corresponding part is utilized only with this specific model number or model number variant.

## Items Found In the “Items Number” Column

All parts with same symbol in the number column, \*, #, +, %, or <, belong to the same assembly or kit

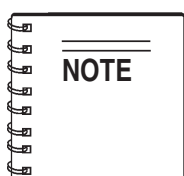

If more than one of the same reference number is listed, the last one listed indicates newest (or latest) part available.

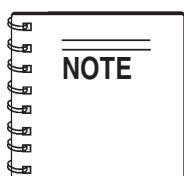

*The contents of this catalog are subject to change without notice.*

# DCA-70SSJU SERIES — SUGGESTED SPARE PARTS

## DCA-70SSJU W/JOHN DEERE 4045TF150 DIESEL ENGINE 1 TO 5 UNITS

<u>Qty.</u>	<u>P/N</u>	<u>Description</u>
1	0601820671	AUTOMATIC VOLTAGE REGULATOR
1	47230107	KNOB, SELECTOR SWITCH
1	0601840073	RHEOSTAT, VOLTAGE REGULATOR
1	0601840121	KNOB, RHEOSTAT
3	0602011490	FAN BELT
20	0602041290	OIL FILTER
20	0602042590	FUEL FILTER
10	0602046357	AIR ELEMENT
1	M2310500203	RADIATOR HOSE, UPPER ..... S/N7300001 TO S/N7300267
1	M2310500303	RADIATOR HOSE, LOWER ..... S/N7300001 TO S/N7300267
1	M2310500403	RADIATOR HOSE, LOWER ..... S/N7300001 TO S/N7300267
1	M2310500503	RADIATOR HOSE, UPPER ..... S/N7300268~
1	M2310500603	RADIATOR HOSE, LOWER ..... S/N7300268~
1	0602100056	STARTER SWITCH ..... S/N7300001 TO S/N73002140
1	AR51481	KEY, STARTER SWITCH ..... S/N7300001 TO S/N73002140
1	06021030912	LAMP, PILOT ALARM
1	0601810245	BULB, PILOT LAMP
1	0602123263	WATER TEMPERATURE UNIT
1	0602122272	OIL PRESSURE UNIT
1	0605505070	FUEL TANK CAP
5	0602042420	FUEL TANK IN-LINE FILTER
1	1625165103	BONNET CAP
1	1625165204	BONNET CAP CHAIN ASSEMBLY
1	0602123261	WATER TEMPERTURE UNIT ..... S/N 7300646~
2	0601808803	CIRCUIT BREAKER, QOU120B 20A
3	0601808804	CIRCUIT BREAKER, QOU250B 50A

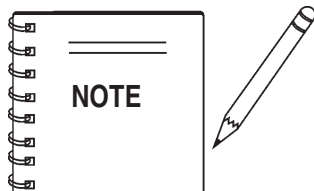

**Part number on this Suggested Spare Parts list may supercede/replace the P/N shown in the text pages of this book.**

# DCA-70SSJU SERIES — NAMEPLATE AND DECALS

## NAMEPLATE AND DECALS

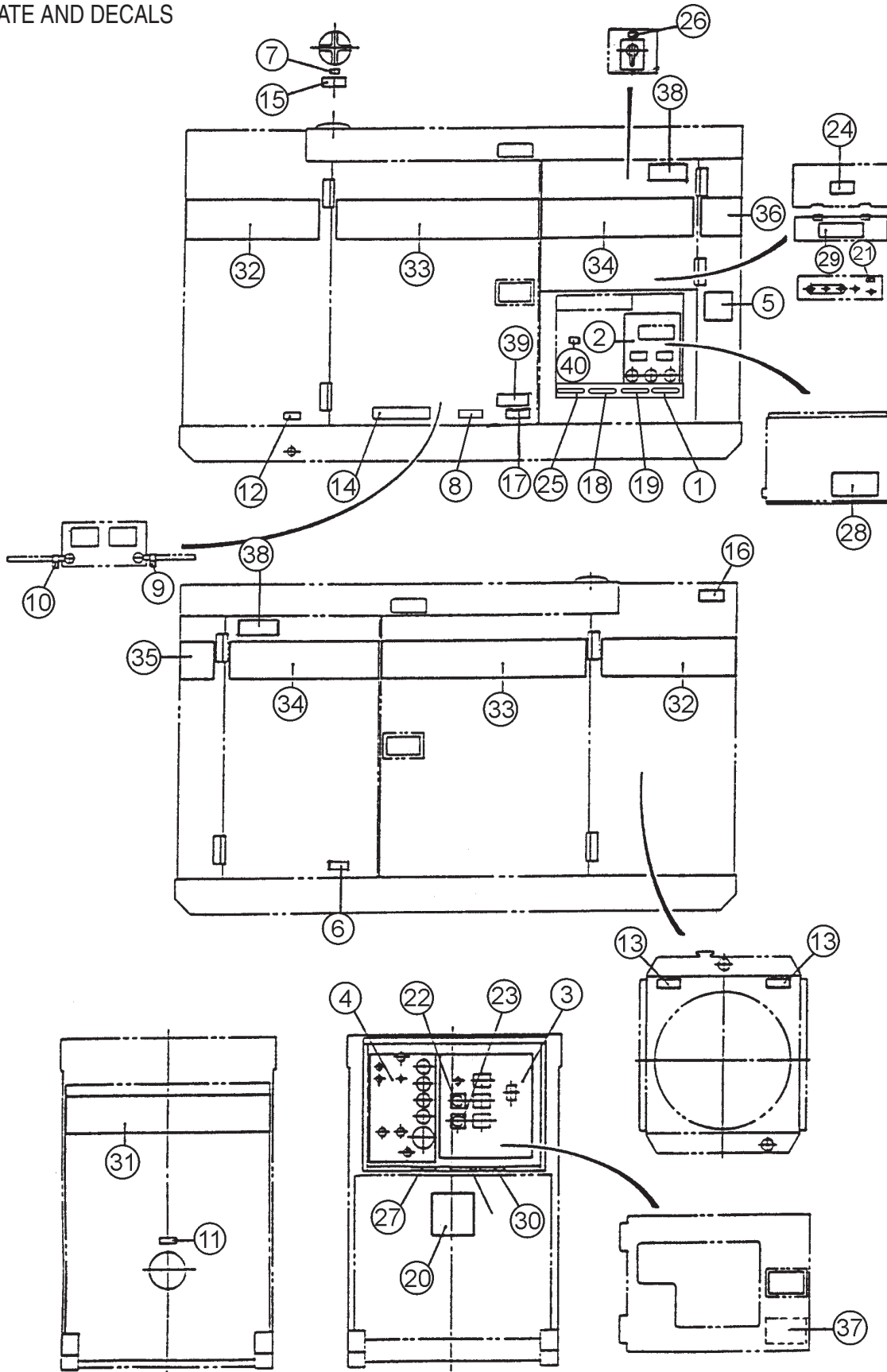



# DCA-70SSJU SERIES — NAMEPLATE AND DECALS

## NAMEPLATE AND DECALS.

<u>NO.</u>	<u>PART NO.</u>	<u>PART NAME</u>	<u>QTY.</u>	<u>REMARKS</u>
1	M1550000204	DECAL, NOTE .....	1 .....	M15000020
2	M1550000703	DECAL, AUXILLARY OUTPUT .....	1 .....	M15000070
3	M2550000002	DECAL, GENERATOR CONTROL .....	1 .....	M25000000
4	M2550000102	DECAL, ENGINE OPERATING .....	1 .....	M25000010
4	M2552000203	DECAL, ENGINE OPERATING .....	1 .....	M25200020
5	M2550000304	DECAL, NOTE .....	1 .....	M25000030
6	M9500000004	DECAL, OIL DRAIN PLUG .....	1 .....	M90000000
7	M9500100004	DECAL, WATER .....	1 .....	M90010000
8	M9500100104	DECAL, WATER DRAIN PLUG .....	1 .....	M90010010
9	M9500300004	DECAL, NEGATIVE .....	1 .....	M90030000
10	M9500300104	DECAL, POSITIVE .....	1 .....	M90030010
11	M9500500004	DECAL, DIESEL FUEL .....	1 .....	M90050000
12	M9500500104	DECAL, FUEL DRAIN PLUG .....	1 .....	M90050010
13	M9503000004	DECAL, WARNING .....	2 .....	M90300000
14	M9503000103	DECAL, WATER OIL CHECK .....	1 .....	M90300010
15	M9503100004	DECAL, WARNING .....	1 .....	M90310000
16	M9503200004	DECAL, WARNING .....	1 .....	M90320000
17	M9510100004	DECAL, CAUTION .....	1 .....	M91010000
18	M9520100503	DECAL, WARNING, M91010010 .....	1 .....	REPLACES M9510100104
19	M9520100503	DECAL, WARNING, M91010020 .....	1 .....	REPLACES M9510100204
20	M9510200002	DECAL, MQ .....	1 .....	M91020000
21	M9520000004	DECAL, GROUND .....	1 .....	M92000000
22	M9520000104	DECAL, AMMETER CHNG.-OVR SW. ....	1 .....	M92000010
23	M9520000204	DECAL, VOLTMETER CHNG.-OVR SW. ....	1 .....	M92000020
24	M9520100004	DECAL, WARNING .....	2 .....	M92010000
25	M9520100503	DECAL, WARNING, M92010010 .....	1 .....	REPLACES M9520100104
	M9520100503	DECAL, WARNING .....	1 .....	M92010050
26	M9520100204	DECAL, CAUTION .....	1 .....	M92010020A
27	M9520100304	DECAL, SAFETY INSTRUCTIONS .....	1 .....	M92010030
28	M9520100404	DECAL, DANGER .....	1 .....	M92010040
29	M9520200003	DECAL, CONNECT. OUTPUT CABLE .....	1 .....	M92020000
30	M9520200104	DECAL, OVER CURRENT RELAY .....	1 .....	M92020010
31	M2560100003	STRIPE, WHISPERWATT	1	
32	M2560100103	STRIPE, MQ POWER	2	
33	M2560100203	STRIPE	2	
34	M2560100403	STRIPE	2	
35	M2560100304	STRIPE, 70	1	
36	M2560100504	STRIPE, 70	1	
37	M3552000103	DECAL, OPERATING PROCEDURES .....	1 .....	M35200010
38	C9522100003	DECAL, CAUTION .....	2 .....	C92210000
39	C9505300004	DECAL, CAUTION .....	1 .....	C90530000
40	9039209064	DECAL, START CONTACT .....	1 .....	S-4468



# DCA-70SSJU SERIES — GENERATOR ASSY.

## GENERATOR ASSY.

<u>NO.</u>	<u>PART NO.</u>	<u>PART NAME</u>	<u>QTY.</u>	<u>REMARKS</u>
1	B5110100602	ROTOR ASSY.....	1	INCLUDE ITEMS W/*
2*		FIELD ASSY.	1	
3*	8101070033	FAN	1	
4*	0012810030	HEX HEAD BOLT	8	
5*	8101611004	COUPLING DISK	5	
6*	8101015003	BALANCING PLATE	1	
7*	012010030	HEX HEAD BOLT .....	8	REPLACES 0012110030
8*	0042610000	LOCK WASHER	8	
9*	8101026013	SET PLATE RECTIFIER	1	
10*	0601821349	RECTIFIER .....	2	PT3610
11*	0601822601	SURGE ABSORBER .....	1	ERZ-M14JK621A
12*	8001020004	INSULATOR WASHER	1	
13*	8001020504	INSULATOR WASHER	1	
14*	012210020	HEX HEAD BOLT .....	4	REPLACES 0010110020
15*	0040010000	LOCK WASHER	4	
16*	0601000209	BALANCING WEIGHT KIT	1	
17*	0071906311	BEARING .....	1	6311DDUC3
18	8101614003A	COUPLING RING .....	1	REPLACES M2163400003
19	0343204170	HEX HEAD BOLT	8	
20	EM923344	LOCK WASHER .....	8	REPLACES 0043604000
21	B5130100303	STATOR ASSY.	1	
22	0845041904	GROMMET	2	
23	8101315202	END BRACKET	1	
24	8101350013	FIELD ASSY. EXCITER	1	
25	0012110070	HEX HEAD BOLT	4	
26	0042610000	LOCK WASHER	4	
27	031110160	PLAIN WASHER .....	4	REPLACES 0041210000
28	0010110045	HEX HEAD BOLT	6	
29	0040010000	LOCK WASHER	6	
30	03111060	PLAIN WASHER .....	6	REPLACES 0041210000
31	8101310014	COVER BEARING	1	
32	8131312014	GASKET BEARING	1	
33	8101331003	COVER END BRACKET	1	
34	0105050616	HEX HEAD BOLT .....	10	REPLACES 0017106012
35	8101333003	COVER END BRACKET	1	
36	0010106030	HEX HEAD BOLT	2	
37	0040006000	LOCK WASHER	1	
38	952404470	PLAIN WASHER .....	2	REPLACES 0041206000
39	012210035	HEX HEAD BOLT .....	12	S/N7300001 TO 7301260 REPLACES 0010310035
39	0012810030	HEX HEAD BOLT .....	12	S/N7301261 TO 7302210
39	0012810035	HEX HEAD BOLT .....	12	S/N7302211~
40	030210250	LOCK WASHER .....	12	S/N7300001 TO 7301260 REPLACES 0042510000
41	8111332014	COVER FAN	1	
42	0605000010	RUBBER SUSPENSION	2	
43	0030012000	HEX NUT	2	
43	0040012000	LOCK WASHER	2	
43	031112230	PLAIN WASHER .....	2	REPLACES 0041212000
44	0070506306	BEARING	1	
45	020106050	NUT .....	1	REPLACES 0600815000

# DCA-70SSJU SERIES — CONTROL BOX ASSY.

CONTROL BOX ASSY.

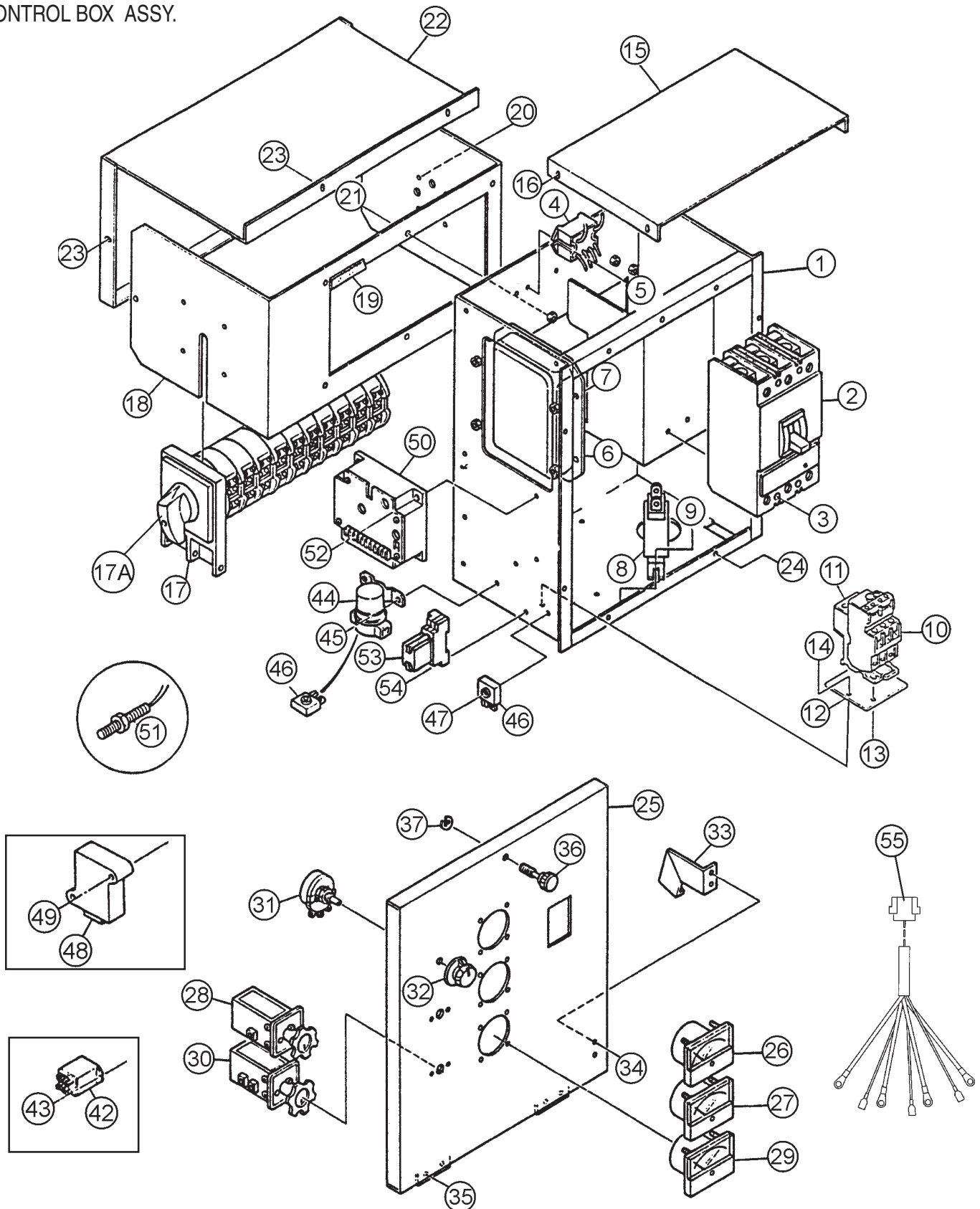

# DCA-70SSJU SERIES — CONTROL BOX ASSY.

## CONTROL BOX ASSY.

<u>NO.</u>	<u>PART NO.</u>	<u>PART NAME</u>	<u>QTY.</u>	<u>REMARKS</u>
1	M2213000102	CONTROL BOX .....	1	UP TO S/N7301040
1	M2213000122	CONTROL BOX .....	1	S/N7301041 TO S/N7302140
1	M2215000103	CONTROL BOX .....	1	S/N7302141~
2	0601808812	CIRCUIT BREAKER .....	1	KAF3617510213P175A
3	0021005080	MACHINE SCREW .....	4	
4	0601823863	RELAY UNIT .....	2	MSA9013A
5	0021304015	MACHINE SCREW .....	4	REPLACES 0027104015
6	0601820671	AUTOMATIC VOLTAGE REGULATOR .....	1	NTA-5A-2DB
7	0027105010	MACHINE SCREW .....	4	S/N7300001 TO S/N7301200
7	0027105015	MACHINE SCREW .....	4	S/N7301201~
8	0601806139	CURRENT TRANSFORMER, 5A .....	3	REPLACES 814943150 AND 0601806117
9	011106015	MACHINE SCREW .....	6	REPLACES 0027106015
10	0601820845	OVER CURRENT RELAY .....	1	LR2D1308
11	0601820846	KIT OVER CURRENT RELAY, LA7D1064	1	
12	M1260600004	FITTING BRACKET .....	1	S/N7300001 TO S/N7301040
13	0021304015	MACHINE SCREW .....	2	REPLACES 0027104015
13	OEMAA8	HEX NUT .....	2	REPLACES 0207004000
14	0027104010	MACHINE SCREW .....	2	S/N7300001 TO S/N7301040
15	M2213500103	CONTROL BOX COVER	1	
16	011106015	HEX HEAD BOLT .....	4	REPLACES 0016906015
17	M2923100004	SELECTOR SWITCH .....	1	VY-80/S
17A	47230107	KNOB, SELECTOR SWITCH	1	
18	M2213600203	SWITCH BRACKET .....	1	S/N7300001 TO S/N7300003
18	M2213600213	SWITCH BRACKET .....	1	S/N7300004~
19	EDGEGES	EDGING .....	2	REPLACES 0330000295
20	0027104010	MACHINE SCREW	4	
21	011106015	HEX HEAD BOLT .....	6	REPLACES 0016906015
22	M2213600314	SWITCH COVER	1	
23	011106015	HEX HEAD BOLT .....	4	REPLACES 0016906015
24	011106015	HEX HEAD BOLT .....	8	REPLACES 0016906015
24	0040506000	TOOTHED WASHER	1	
25	M2223000103	CONTROL PANEL	1	
26	0601807630	FREQUENCY METER, 264250DJDJ9 .....	1	UP TO S/N7302695 REPLACES 0601807696
26	0601807641	FREQUENCY METER, FCF6 45~65Hz 240V .....	1	S/N7302696~
27	0601808955	AC AMMETER, 260240LSX1JBP .....	1	UP TO S/N7302695 REPLACES 0601808943
27	0601808987	AC AMMETER, ACF-6 .....	1	S/N7302696~
28	0601801040	CHANGE-OVER SWITCH AMMETER .....	1	SL-2AS

# DCA-70SSJU SERIES — CONTROL BOX ASSY. (CONT.)

CONTROL BOX ASSY. (CONT.)

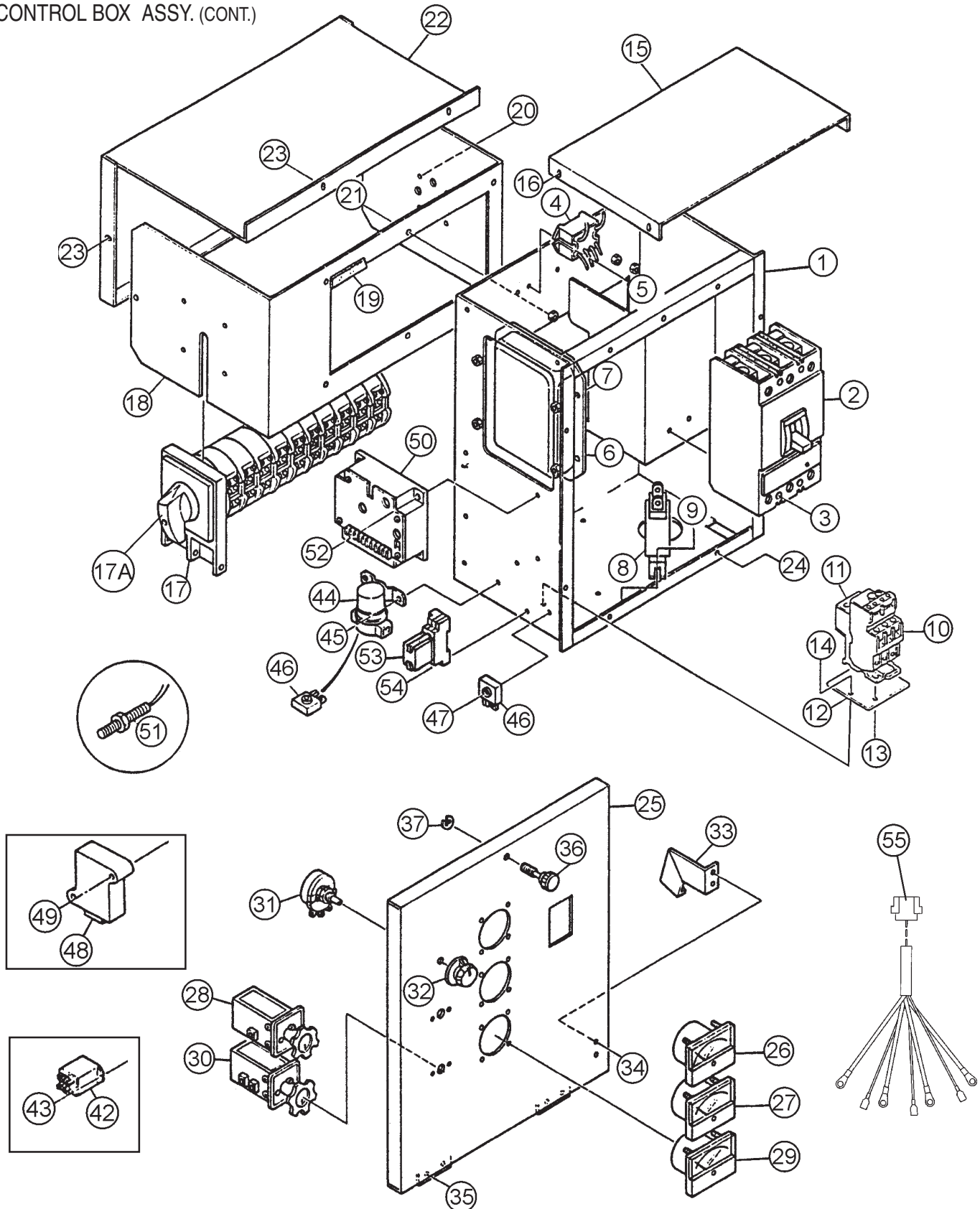

# DCA-70SSJU SERIES — CONTROL BOX ASSY. (CONT.)

## CONTROL BOX ASSY. (CONT.)

<u>NO.</u>	<u>PART NO.</u>	<u>PART NAME</u>	<u>QTY.</u>	<u>REMARKS</u>
29	0601806813	AC VOLTMETER, 260244SJSJ1 .....	1	UP TO S/N7302695 REPLACES 0601806896
29	0601806859	AC VOLTMETER, SCF-6 .....	1	S/N7302696~
30	0601801041	CHANGE-OVER SWITCH VOLTMETER .....	1	SL-2VS
31	0601840073	REOSTAT, VOLTAGE REGULATOR	1	
32	0601840121	KNOB	1	
33	M1223100004	STOPPER	1	
34	0027105015	MACHINE SCREW .....	2	S/N7300001 TO S/N7300505
34	0027105010	MACHINE SCREW .....	2	S/N7300506~
35	0027105015	MACHINE SCREW .....	4	S/N7300001 TO S/N7300505
35	0027105010	MACHINE SCREW .....	4	S/N7300506~
36	M9220100004	SET SCREW	1	
37	0080200007	SNAP RING	1	
38	0602202525	CONTROLLER 0530000593 .....	1	S/N7300001 TO S/N7300645
39	0027105015	MACHINE SCREW .....	2	S/N7300001 TO S/N7300645
40	0601823707	RELAY, CA1A12V-N-5ACA-12135 .....	1	S/N7300001 TO S/N7300645
41	0027105015	MACHINE SCREW .....	1	S/N7300001 TO S/N7300645
42	0601826052	RELAY, HH62S-FDC12V .....	2	S/N7300001 TO S/N7300645
43	0027103010	MACHINE SCREW .....	4	S/N7300001 TO S/N7300645
44	0602202592	STARTER RELAY AT141011	1	
45	011106015	MACHINE SCREW .....	2	REPLACES 0027106015
46	0601821370	RECTIFIER DE4503 .....	1	REPLACES 0601823240
47	0027104020	MACHINE SCREW .....	1	S/N7300261~
48	0602200478	EMERGENCY RELAY, A1070160602,3 .....	1	S/N7300646 TO S/N7302140
49	0027105040	MACHINE SCREW .....	2	S/N7300646 TO S/N7302140
50	DYN110794000012	CONTROLLER .....	1	S/N7302141~ REPLACES 0602202599
51	MSP6724	SPEED SENSOR .....	1	S/N7302141~ REPLACES 0602120485
52	0027105015	MACHINE SCREW .....	4	S/N7302141~
53	LY2DUS12VDC	RELAY .....	1	S/N7302141~ REPLACES 0601827656
53	PTF08A	BASE .....	1	S/N7302141~ REPLACES 0601823109
53	PYCA1	CLIP .....	2	S/N7302141~ REPLACES 0601824400
54	0027104020	MACHINE SCREW .....	2	S/N7302141~
55	M2246700004	WIRE HARNESS GENERATOR .....	1	S/N7300001 TO S/N7300365
55	M2246700014	WIRE HARNESS GENERATOR .....	1	S/N7300365 TO S/N7301090
55	M2246700024	WIRE HARNESS GENERATOR .....	1	S/N7301091~

# DCA-70SSJU SERIES — ENGINE AND RADIATOR ASSY.

ENGINE AND RADIATOR ASSY.

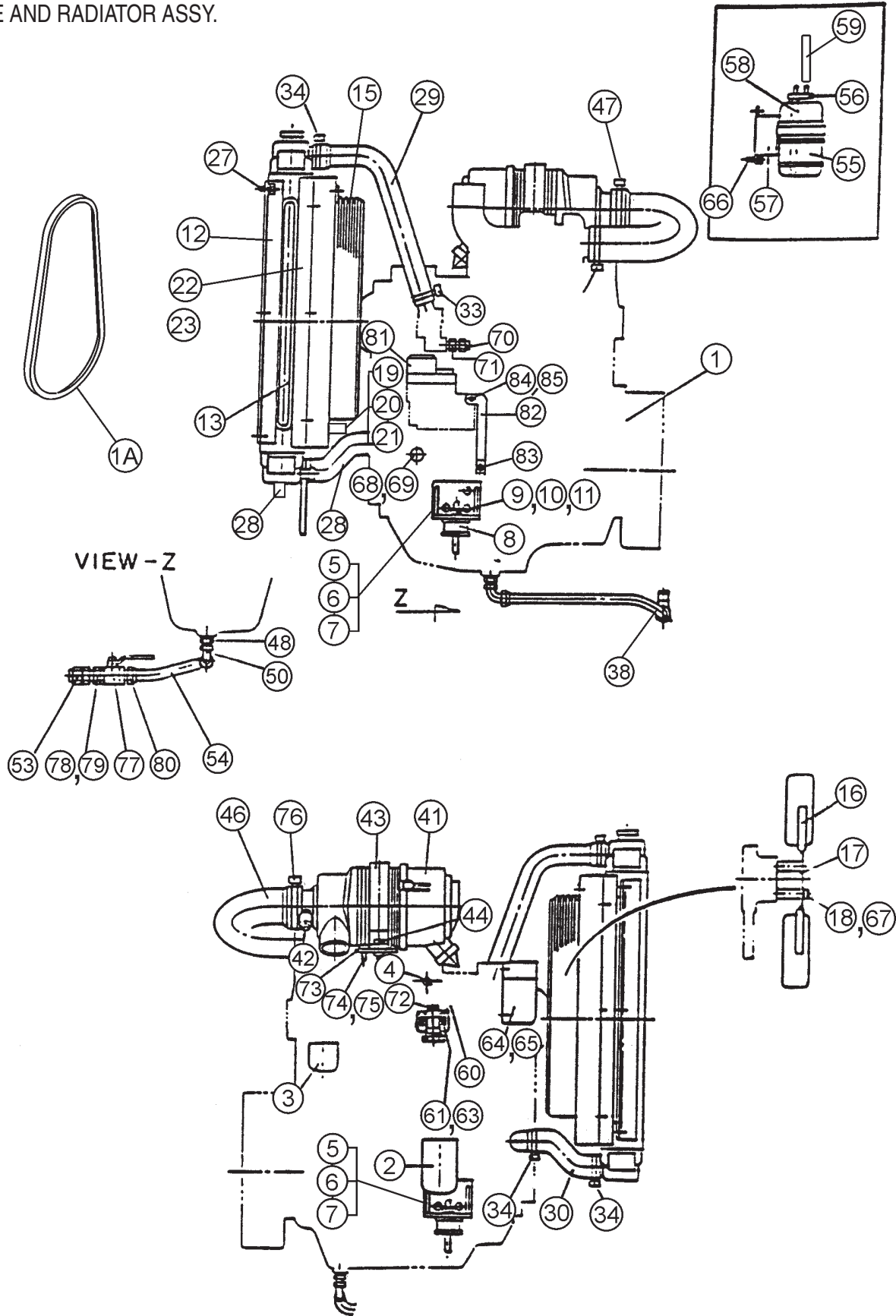



# DCA-70SSJU SERIES — ENGINE AND RADIATOR ASSY.

## ENGINE AND RADIATOR ASSY.

<b>NO.</b>	<b>PART NO.</b>	<b>PART NAME</b>	<b>QTY.</b>	<b>REMARKS</b>
1	M2923200004	ENGINE, JOHN DEERE 4045T .....	1 .....	S/N7300001 TO S/N7302045
1	M2923200004	ENGINE, JOHN DEERE 4045TF150 .....	1 .....	S/N7302046~
1A	0602011490	FAN BELT	1	
2	0602041290	ELEMENT OIL FILTER .....	1 .....	RE59754A
3	0602042590	ELEMENT FUEL FILTER .....	1 .....	RE62418
4	0602014297	ELECTRIC HEATER; RE29658 .....	1 .....	S/N7300001 TO S/N7300720
4	RE502668	ELECTRIC HEATER ASSY. ....	1 .....	S/N7000721~
5	M2303200303	ENGINE FOOT	2	
6	0131151240	HEX HEAD BOLT .....	6 .....	REPLACES 0010312030
7	0040012000	LOCK WASHER	6	
8	0605000009	RUBBER SUSPENSION	2	
9	0030012000	HEX NUT	2	
10	0040012000	LOCK WASHER	2	
11	031112230	PLAIN WASHER .....	2 .....	REPLACES 0041212000
12	0602011998	RADIATOR .....	1 .....	S/N7300001 TO S/N7300267
12	0602011999	RADIATOR .....	1 .....	S/N7300268~
13	C2810034100	SHROUD .....	1 .....	S/N7300001 TO S/N7300267
		.....		REPLACES 0602010690
14	0605515148	HOSE BAND .....	1 .....	S/N7300001 TO S/N7300267
15	0602010780	FAN COVER .....	1 .....	S/N7300001 TO S/N7300267
16	0602060011	BLOWER FAN .....	1 .....	320606
17	0602061000	FAN SPACER .....	1 .....	R81911
18	0012110090	FAN BOLT;19M7811 .....	4 .....	S/N7300001 TO S/N7300220;
		.....		REPLACES 0602060500
18	0012110095	HEX HEAD BOLT .....	4 .....	S/N7300401~
19	011008015	HEX HEAD BOLT .....	6 .....	S/N7300001 TO S/N7300267
		.....		REPLACES 0013004308
20	0043004000	LOCK WASHER .....	4 .....	S/N7300001 TO S/N7300267
21	0043104000	PLAIN WASHER .....	4 .....	S/N7300001 TO S/N7300267
22	M2310200304	RADIATOR BRACKET .....	1 .....	S/N7300001 TO S/N7300003
22	M2310200314	RADIATOR BRACKET .....	1 .....	S/N7300004 TO S/N7300267
23	M2310200204	RADIATOR BRACKET .....	1 .....	S/N7300001 TO S/N7300003
23	M2310200214	RADIATOR BRACKET .....	1 .....	S/N7300004 TO S/N7300267
27	011008020	HEX HEAD BOLT .....	6 .....	REPLACES 0016908020
28	0138102000	PLUG .....	1 .....	S/N7300001 TO S/N7300267
29	M2310500203	RADIATOR HOSE, UPPER .....	1 .....	S/N7300001 TO S/N7300267
29	M2310500503	RADIATOR HOSE, UPPER .....	1 .....	S/N7300268~
30	M2310500303	RADIATOR HOSE, LOWER .....	1 .....	S/N7300001 TO S/N7300267
30	M2310500603	RADIATOR HOSE, LOWER .....	1 .....	S/N7300268~
31	M2310500403	RADIATOR HOSE, LOWER .....	1 .....	S/N7300001 TO S/N7300267
32	M2310400004	DRAIN PIPE .....	1 .....	S/N7300001 TO S/N7300267

# DCA-70SSJU SERIES — ENGINE AND RADIATOR ASSY. (CONT.)

## ENGINE AND RADIATOR ASSY.

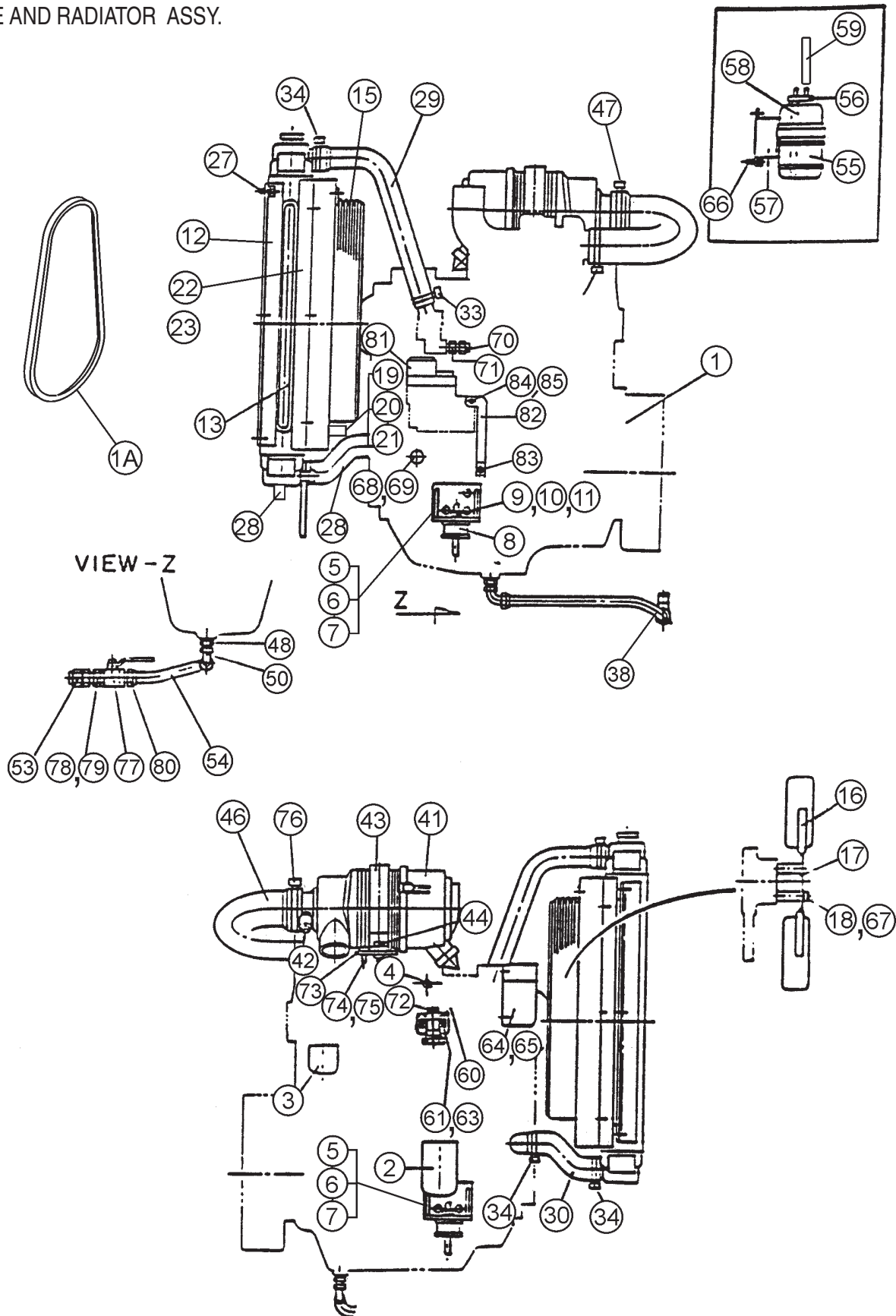

# DCA-70SSJU SERIES — ENGINE AND RADIATOR ASSY. (CONT.)

## ENGINE AND RADIATOR ASSY.

<b>NO.</b>	<b>PART NO.</b>	<b>PART NAME</b>	<b>QTY.</b>	<b>REMARKS</b>
33	0605515199	HOSE BAND .....	1	S/N7300001 TO S/N7300267
33	0605515201	HOSE BAND .....	1	S/N7300268~
34	0605515147	HOSE BAND .....	3	S/N7300268~
35	781204003B	DRAIN JOINT .....	1	S/N7300001 TO S/N7300267
		.....		REPLACES M2320300103
36	M9200200004	DRAIN BOLT .....	1	S/N7300001 TO S/N7300267
37	0150000018	O RING .....	1	S/N7300001 TO S/N7300267
38	011206020	HEX HEAD BOLT .....	2	S/N7300001 TO S/N7300267
		.....		REPLACES 0016906020
39	0199900685	DRAIN HOSE .....	1	S/N7300001 TO S/N7300267
40	0605515106	HOSE BAND .....	2	S/N7300001 TO S/N7300267
41	0602046233	AIR CLEANER, FWG080061 .....	1	S/N7300001 TO S/N7302330
41	0602046582	AIR CLEANER, FPG082527 .....	1	S/N7302331~
41	0602046357	ELEMENT AIR CLEANER, P18-1054 .....	1	S/N7300001 TO S/N7302330
41	0602046365	ELEMENT AIR CLEANER, P828889 .....	1	S/N7302331~
42	0602040650	INDICATOR AIR CLEANER .....	1	S/N7300001 TO S/N7302330
42	0602040651	INDICATOR AIR CLEANER .....	1	S/N7302331~
43	0602040590	BAND AIR CLEANER .....	2	S/N7300001 TO S/N7302330
43	0602040554	BAND AIR CLEANER .....	1	S/N7302331~
44	011008020	HEX HEAD BOLT .....	4	S/N7300001 TO S/N7302330
		.....		REPLACES 0016908020
46	M2373100103	HOSE AIR CLEANER .....	1	S/N7300001 TO S/N7302330
46	M2375100003	HOSE AIR CLEANER .....	1	S/N7302331~
47	0605515146	HOSE BAND .....	2	S/N7300001 TO S/N7302330
47	0605515146	HOSE BAND .....	1	S/N7302331~
48	0602022563	ADAPTER	1	
49	0602021165	O RING .....	1	S/N7300001 TO S/N7300991
50	0602022561	90 ELBOW	1	
51	0602022562	UNION .....	1	S/N7300001 TO S/N7302330
52	0602022792	SWIVEL .....	1	S/N7300001 TO S/N7302140
53	0602021070	CAP	1	
54	0602021572	DRAIN HOSE .....	1	S/N7300001 TO S/N7302140
54	0269200600	DRAIN HOSE .....	1	S/N7302141~
55	M9300000103	RESERVE TANK	1	
56	0802081104	CAP RESERVE TANK .....	1	REPLACES M9300100003
57	M2316100104	BRACKET RESERVE TANK .....	1	S/N7300001 TO S/N7300003
57	M2316100204	BRACKET RESERVE TANK .....	1	REPLACES M9300100003
58	0199100200	HOSE	1	
59	0193601500	HOSE .....	1	S/N7300001 TO S/N7300267
60	M2260600014	RELAY BRACKET .....	1	S/N7300001 TO S/N7301310

# DCA-70SSJU SERIES — ENGINE AND RADIATOR ASSY. (CONT.)

ENGINE AND RADIATOR ASSY.

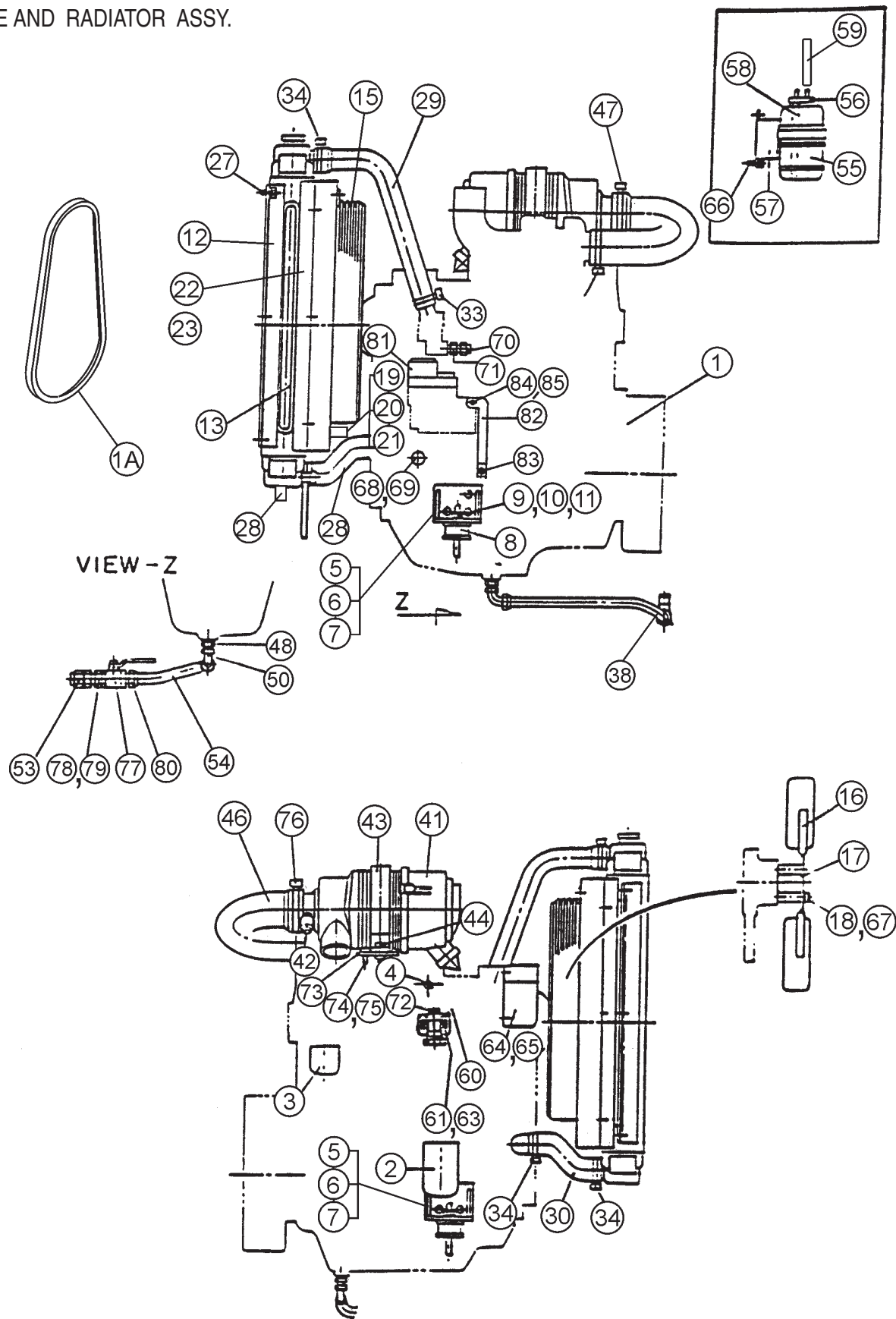

# DCA-70SSJU SERIES — ENGINE AND RADIATOR ASSY. (CONT.)

## ENGINE AND RADIATOR ASSY.

<b>NO.</b>	<b>PART NO.</b>	<b>PART NAME</b>	<b>QTY.</b>	<b>REMARKS</b>
60	M2260600024	RELAY, BRACKET .....	1 .....	S/N7301311~
61	0602202597	RELAY, AL81719 .....	1 .....	S/N7300001 TO 7301310
61	0602202592	RELAY, AT141011 .....	1 .....	S/N7301311~
62	0602220621	TERMINAL COVER .....	1 .....	S/N7300001 TO S/N7300003
63	0017105015	HEX HEAD BOLT .....	1 .....	S/N7300001 TO S/N7301310
63	011106015	MACHINE SCREW .....	2 .....	S/N7301311~
		.....		REPLACES 0027106015
64	M2483400014	ALTERNATOR COVER	1	
65	011206020	HEX HEAD BOLT .....	2 .....	REPLACES 0016906020
66	011008020	HEX HEAD BOLT .....	2 .....	S/N7 300004~
		.....		REPLACES 0016908020
67	030210250	LOCK WASHER .....	4 .....	S/N7300221~
		.....		REPLACES 0042510000
68	1718939010	OIL SWITCH .....	1 .....	S/N 7300646~
		.....		REPLACES 0602122281
69	M9200100704	ADAPTER .....	1 .....	S/N7300646~
70	1518183040	WATER SWITCH .....	1 .....	S/N 7300646~
		.....		REPLACES 0602123282
71	M9200100404	ADAPTER .....	1 .....	S/N 7300646~
72	012210020	HEX HEAD BOLT .....	1 .....	S/N7301311~
		.....		REPLACES 0017110020
73	M2375200004	BRACKET, AIR CLEANER .....	1 .....	S/N7302331~
74	011008020	HEX HEAD BOLT .....	4 .....	S/N7302331~
		.....		REPLACES 0016908020
75	020108060	HEX NUT .....	4 .....	S/N7302331~
		.....		REPLACES 0207008000
76	0605515200	HOSE BAND .....	1 .....	S/N7302331~
77	0605511395	VALVE, XV500P-8 .....	1 .....	S/N7302141~
78	0603306590	CONNECTOR .....	1 .....	S/N7302141~
79	0603300285	ROCK NUT .....	1 .....	S/N7302141~
80	0603306395	HOSE JOINT .....	1 .....	S/N7302141~
81	DYNC70025000012	ACTUATOR .....	1 .....	S/N7302141~
		.....		REPLACES0602150093
82	M3356200004	STOPPER BRACKET .....	1 .....	S/N7302141~
83	012210020	HEX HEAD BOLT .....	1 .....	S/N7302141~
		.....		REPLACES 0017110020
84	011206020	HEX HEAD BOLT .....	1 .....	S/N7302141~
		.....		REPLACES 0016906020
85	0207006000	HEX NUT .....	1 .....	S/N7302141~

# DCA-70SSJU SERIES — ENGINE OPERATING PANEL ASSY.

ENGINE OPERATING ASSY.

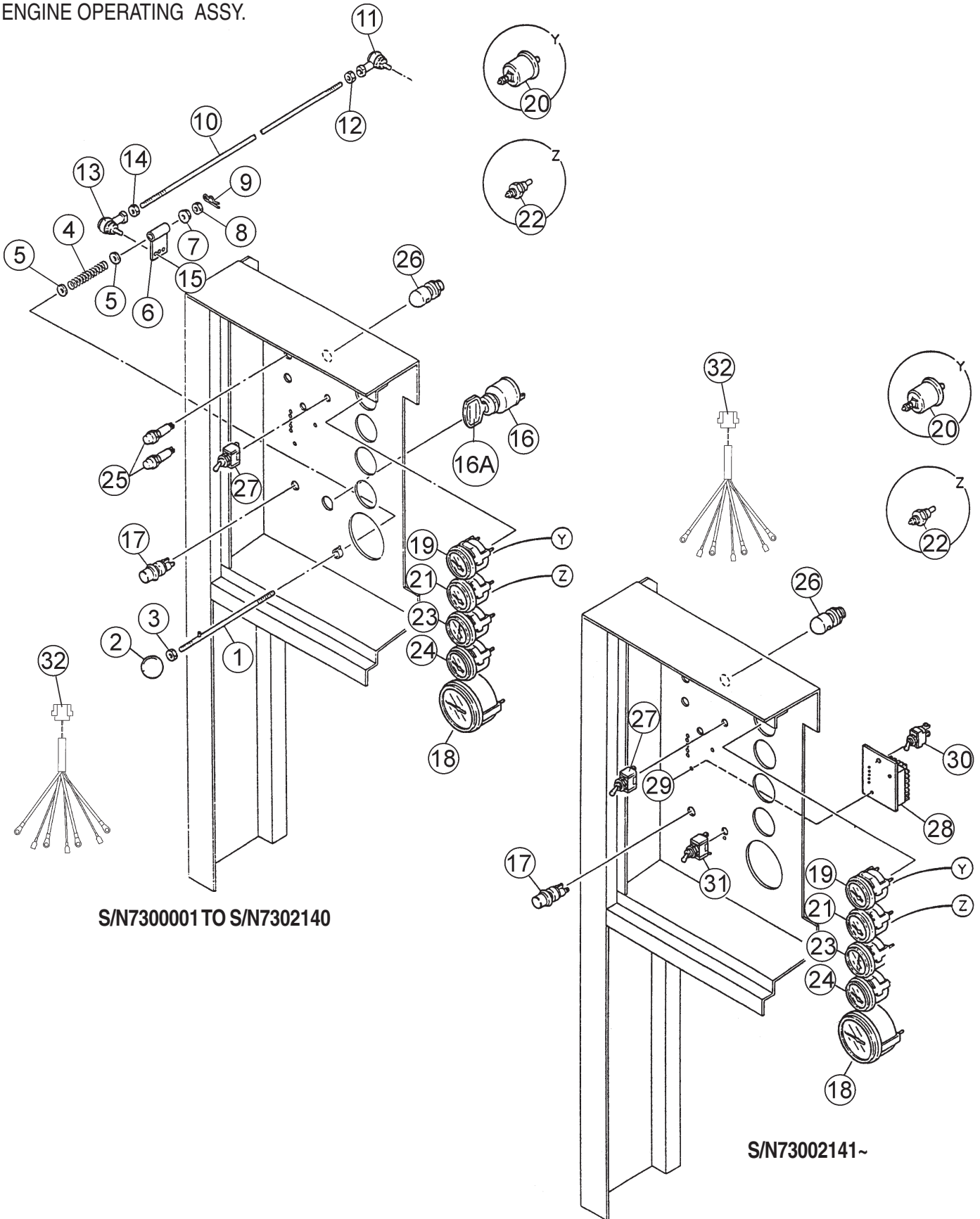

S/N7300001 TO S/N7302140

S/N73002141~

# DCA-70SSJU SERIES — ENGINE OPERATING PANEL ASSY.

## ENGINE OPERATING ASSY.

<u>NO.</u>	<u>PART NO.</u>	<u>PART NAME</u>	<u>QTY.</u>	<u>REMARKS</u>
1	M1354300304	SLIDE LEVER .....	1 .....	S/N7300001 TO S/N7302140
2	0601840190	KNOB .....	1 .....	S/N7300001 TO S/N7302140
		.....		REPLACES M9320000004
3	020108060	HEX. NUT .....	1 .....	S/N7300001 TO S/N7302140
		.....		REPLACES 0036003000
4	0605804150	SPRING .....	1 .....	S/N7300001 TO S/N7302140
5	031108160	PLAIN WASHER .....	2 .....	S/N7300001 TO S/N7302140
		.....		REPLACES 0041208000
6	M1354200004	BRACKET .....	1 .....	S/N7300001 TO S/N7302140
7	020108060	HEX. NUT .....	1 .....	S/N7300001 TO S/N7302140
		.....		REPLACES 0207008000
8	020108060	HEX. NUT .....	1 .....	S/N7300001 TO S/N7302140;
		.....		REPLACES 0030008000
9	0605010550	SNAP PIN .....	1 .....	S/N7300001 TO S/N7302140
10	M2354300104	GOVERNOR ROD .....	1 .....	S/N 730001 TO S/N7300003
10	M2354300114	GOVERNOR ROD .....	1 .....	S/N7300004 TO S/N7302140
11	0602180106	BALL JOINT .....	1 .....	S/N7300001 TO S/N7302140
12	020108060	HEX. NUT .....	1 .....	S/N7300001 TO S/N7302140
		.....		REPLACES 0030008000
13	0602180107	BALL JOINT .....	1 .....	S/N7300001 TO S/N7302140
14	0039308000	HEX. NUT .....	1 .....	S/N7300001 TO S/N7302140
		.....		REPLACES 0036508000
15	952404470	HEX. NUT .....	2 .....	S/N7300001 TO S/N7302140
		.....		REPLACES 0207006000
15	952404470	PLAIN WASHER .....	2 .....	S/N7300001 TO S/N7302140
		.....		REPLACES 0041206000
16	0602100056	STARTER SWITCH;AR58126 .....	1 .....	S/N7300001 TO S/N7302140
16	0602100028	SET NUT .....	1 .....	S/N7300001 TO S/N7302140
16	0602100029	SET WASHER .....	1 .....	S/N7300001 TO S/N7302140
16A	AR51481	KEY, STARTER SWITCH .....	1 .....	S/N7300001 TO S/N7302140
17	0601831594	COLD STARTING BUTTON, R39554 .....	1 .....	S/N7300001 TO S/N7301510
17	0601831585	COLD STARTING BUTTON, 44047 .....	1 .....	S/N7301511~

# DCA-70SSJU SERIES — ENGINE OPERATING PANEL ASSY. (CONT.)

ENGINE OPERATING ASSY. (CONT.)

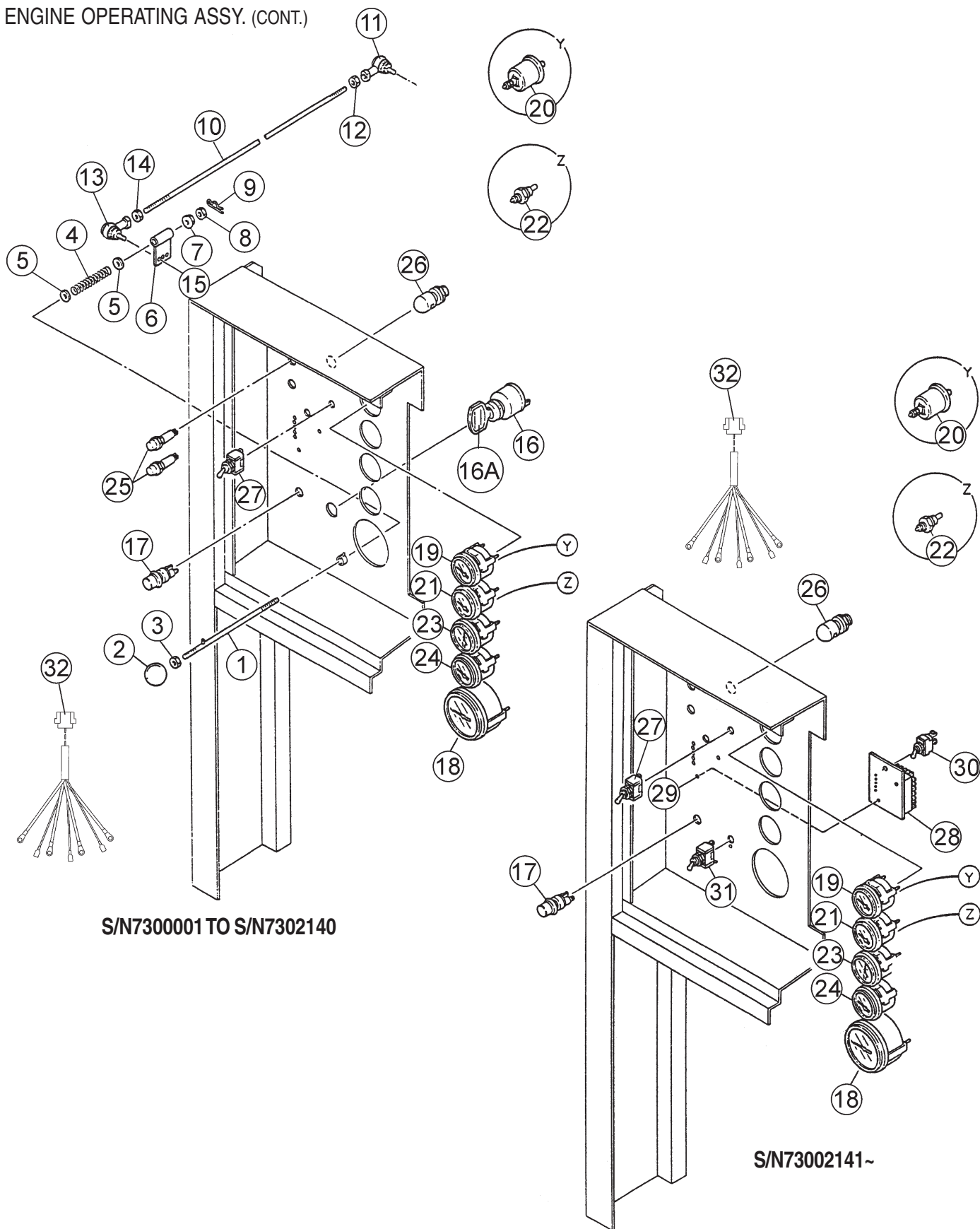



# DCA-70SSJU SERIES — ENGINE OPERATING PANEL ASSY. (CONT.)

## ENGINE OPERATING ASSY. (CONT.)

<b>NO.</b>	<b>PART NO.</b>	<b>PART NAME</b>	<b>QTY.</b>	<b>REMARKS</b>
17	0601831584	CAP .....	1	S/N7300001 TO S/N7301510
17	0601831586	CAP .....	1	S/N7301511~
17	0602202450	WIRING READ .....	1	S/N7300001 TO S/N7300220
17	0602202451	WIRING READ .....	1	S/N7300001 TO S/N7300220
18	0602120096	TACHOMETER .....	1	103678
19	0602122094	OIL PRESSURE GAUGE, 106068 .....	1	S/N7300001 TO S/N7300645
19	0602122093	OIL PRESSURE GAUGE, 100174 .....	1	S/N7300646~
20	0602122272	UNIT, OIL PRESSURE, 102225 .....	1	REPL.0602122207&0602122271
21	0602123091	WATER TEMPERATURE GAUGE, 106078 .....	1	S/N7300001 TO S/N7300645
21	0602123092	WATER TEMPERATURE GAUGE, 100182 .....	1	S/N7300646~
22	0602123263	UNIT, WATER TEMPERATURE, 0208900 .....	1	S/N7300001 TO S/N7300645
22	0602123261	UNIT, WATER TEMPERATURE, 0202500 .....	1	S/N7300646~
23	0602121080	CHARGING AMMETER .....	1	100158
24	0602125090	FUEL GAUGE .....	1	100176
25	0602103092	ALARM LAMP .....	2	S/N7300001 TO S/N7302140
25	0601810245	BULB, 18V .....	2	S/N7300001 TO S/N7302140
26	0601810141	PANEL LIGHT	1	
27	0601831330	SWITCH, PANEL LIGHT .....	1	90-0001
28	ECU9988NJD	ENGINE CONTROLLER .....	1	S/N7302141~
		.....		REPLACES 0602202545
29	0027104035	MACHINE SCREW .....	2	S/N7302141~
29	OEMAA8	HEX NUT .....	2	S/N7302141~
		.....		REPLACES 0207004000
30	82608	SWITCH, 7562K4 .....	1	S/N7302141~
		.....		REPLACES 0601831340
31	0601831395	SWITCH, 7302K36 .....	1	S/N7302141~
32	M2357200042	WIRE HARNESS, ENGINE .....	1	UP TO S/N7301310
32	M2357200052	WIRE HARNESS, ENGINE .....	1	S/N7301311 TO S/N7302140
32	M2357200062	WIRE HARNESS, ENGINE .....	1	S/N730141~

# DCA-70SSJU SERIES — OUTPUT TERMINAL ASSY.

OUTPUT TERMINAL ASSY.

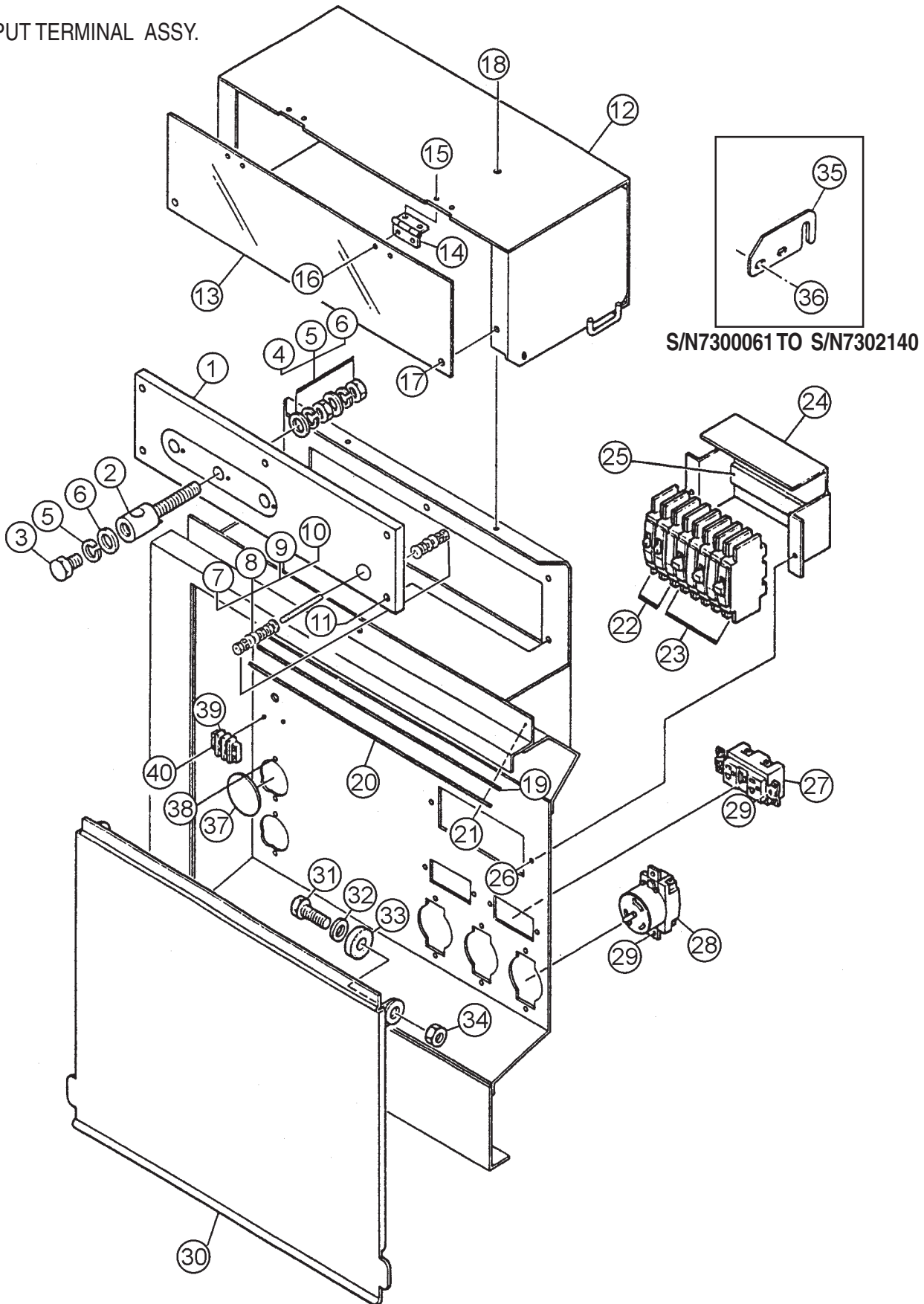

# DCA-70SSJU SERIES — OUTPUT TERMINAL ASSY.

## OUTPUT TERMINAL ASSY.

<u>NO.</u>	<u>PART NO.</u>	<u>PART NAME</u>	<u>QTY.</u>	<u>REMARKS</u>
1	8081860103	TERMINAL PANEL .....	1 .....	S/N7300001 TO S/N7300365 REPLACES M2230700003
1	M2230700113	TERMINAL PANEL .....	1 .....	S/N7300366~
2	M2233000004	OUTUT TERMINAL BOLT .....	4 .....	S/N7300001 TO S/N7300365
2	M2233000004	OUTPUT TERMINAL BOLT .....	5 .....	S/N7300366~
3	M2233100004	TIE BOLT .....	4 .....	S/N7300001 TO S/N7300365
3	M2233100004	TIE BOLT .....	5 .....	S/N7300366~
4	0039312000	HEX NUT .....	8 .....	S/N7300001 TO S/N7300365
4	0039312000	HEX NUT .....	10 .....	S/N7300366~
5	0040012000	LOCK WASHER .....	12 .....	S/N7300001 TO S/N7300365
5	0040012000	LOCK WASHER .....	15 .....	S/N7300366~
6	0041412000	PLAIN WASHER .....	16 .....	S/N7300001 TO S/N7300365
6	0041412000	PLAIN WASHER .....	20 .....	S/N7300366~
7	M2233700004	STUD BOLT .....	1 .....	S/N7300001 TO S/N7300365
8	0039306000	HEX NUT .....	5 .....	S/N7300001 TO S/N7300365
9	0040006000	PLAIN WASHER .....	2 .....	S/N7300001 TO S/N7300365
10	0041406000	PLAIN WASHER .....	5 .....	S/N7300001 TO S/N7300365
11	0012108035	HEX HEAD BOLT .....	5 .....	S/N7300001 TO S/N7300365 REPLACES 0016908035
12	M2236100403	TERMINAL COVER .....	1 .....	S/N7300001 TO S/N7300060
12	M2236100413	TERMINAL COVER .....	1 .....	S/N7300061 TO S/N7301140
12	M2236100423	TERMINAL COVER .....	1 .....	S/N7301141 TO S/N7301260
12	M2236100433	TERMINAL COVER .....	1 .....	S/N7301261 TO S/N7302175
12	M2236100003	TERMINAL COVER .....	1 .....	S/N7302176~
13	M2236100504	OUTPUT WINDOW .....	1 .....	S/N73012611 TO S/N7302175
13	M3236100104	OUTPUT WINDOW .....	1 .....	S/N7302176~
14	0605010040	HINGE	2	
15	0027103010	MACHINE SCREW	4	
15	0207003000	HEX NUT .....	4 .....	REPLACES 0030003000
15	58413	PLAIN WASHER .....	4 .....	REPLACES 0041203000
16	0027103010	MACHINE SCREW	4	
16	0207003000	HEX NUT .....	4 .....	REPLACES 0030003000
17	011206020	HEX HEAD BOLT .....	2 .....	REPLACES 0016906020
18	011106015	HEX HEAD BOLT .....	4 .....	REPLACES 0016906015
19	M1236400004	CABLE OUTPUT COVER .....	1 .....	S/N7300001 TO S/N7300140
19	M3236400004	CABLE OUTPUT COVER .....	1 .....	S/N73000141~
20	M1236300004	SUPPORTER, CABLE OUTLET CVR. ....	1 .....	S/N7300001 TO S/N7300140
20	M3236300004	SUPPORTER, CABLE OUTLET CVR. ....	1 .....	S/N7300141~
21	011206020	HEX HEAD BOLT .....	6 .....	REPLACES 0016906020
22	0601808803	CIRCUIT BREAKER .....	2 .....	QOU120B1P20A
23	0601808804	CIRCUIT BREAKER .....	3 .....	QOU250B2P50A

# DCA-70SSJU SERIES — OUTPUT TERMINAL ASSY. (CONT.)

OUTPUT TERMINAL ASSY. (CONT.)

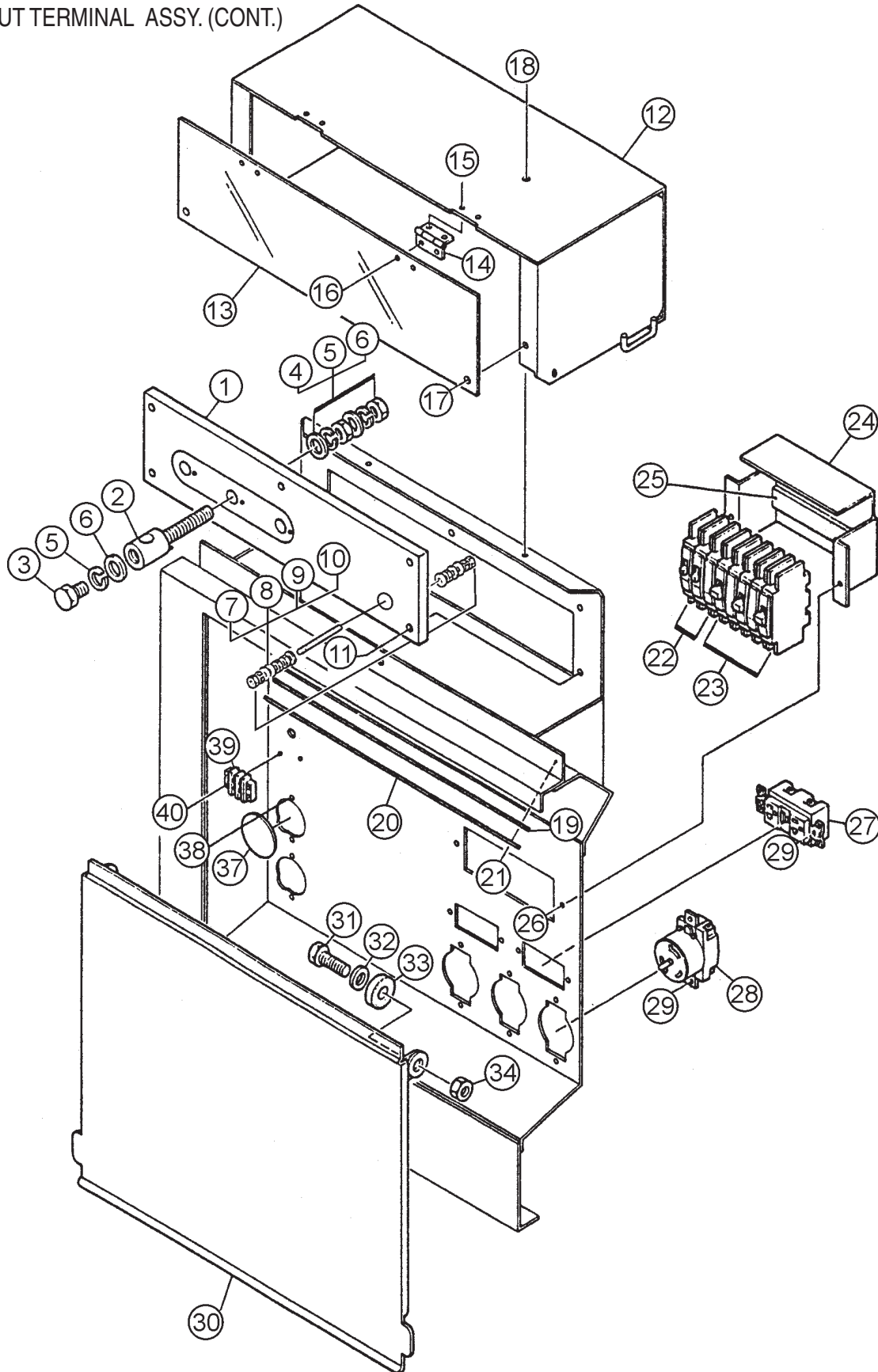

# DCA-70SSJU SERIES — OUTPUT TERMINAL ASSY. (CONT.)

## OUTPUT TERMINAL ASSY. (CONT.)

<u>NO.</u>	<u>PART NO.</u>	<u>PART NAME</u>	<u>QTY.</u>	<u>REMARKS</u>
24	M1260700304	BREAKER FITTING COVER	1	
25	0222100150	CUSHION RUBBER	1	
26	0016906020	HEX HEAD BOLT	2	
27	011206020	RECEPTACLE, GF5342125V 20A X 2 .....	2	S/N7300001 TO S/N7300365
		.....		REPLACES 0601812540
27	0601812597	RECEPTACLE, GF530EM 125V 20A X2 ...	2	S/N7300366~
		.....		REPLACES 0601812598
28	0601811034	RECEPTACLECS, 6369 250V 50A .....	3	S/N7300001 TO S/N7300365
		.....		REPLACES 0601812548
28	0601812538	RECEPTACLE, CS6369 250V 50A .....	3	S/N7300366~
29	0021304015	MACHINE SCREW .....	10	REPLACES 0027104015
29	0030004000	HEX NUT .....	10	REPLACES 0207004000
30	M2236100303	TERMINAL COVER .....	1	S/N7300001 TO S/N7302175
30	M2455400003	TERMINAL COVER .....	1	S/N7302176~
31	012212045	HEX HEAD BOLT .....	2	REPLACES 0010112045
32	031112230	PLAIN WASHER .....	2	REPLACES 0041212000
33	M9310200004	STAY RUBBER	2	
34	0030012000	NUT	2	
35	M2354200004	SUPPORTER, GOVERNOR ROD .....	1	S/N7300061 TO S/N7302140
36	011106015	HEX HEAD BOLT .....	2	S/N7300061 TO S/N7302140
		.....		REPLACES 0016906015
37	0603306775	PLUG .....	2	S/N7302176~
38	0021304015	MACHINE SCREW .....	4	S/N7302176~
		.....		REPLACES 0027104015
39	0601815194	TERMINAL .....	1	S/N7302141~
40	0021304015	MACHINE SCREW .....	2	S/N7302141~
		.....		REPLACES 0027104015

# DCA-70SSJU SERIES — BATTERY ASSY.

BATTERY ASSY.

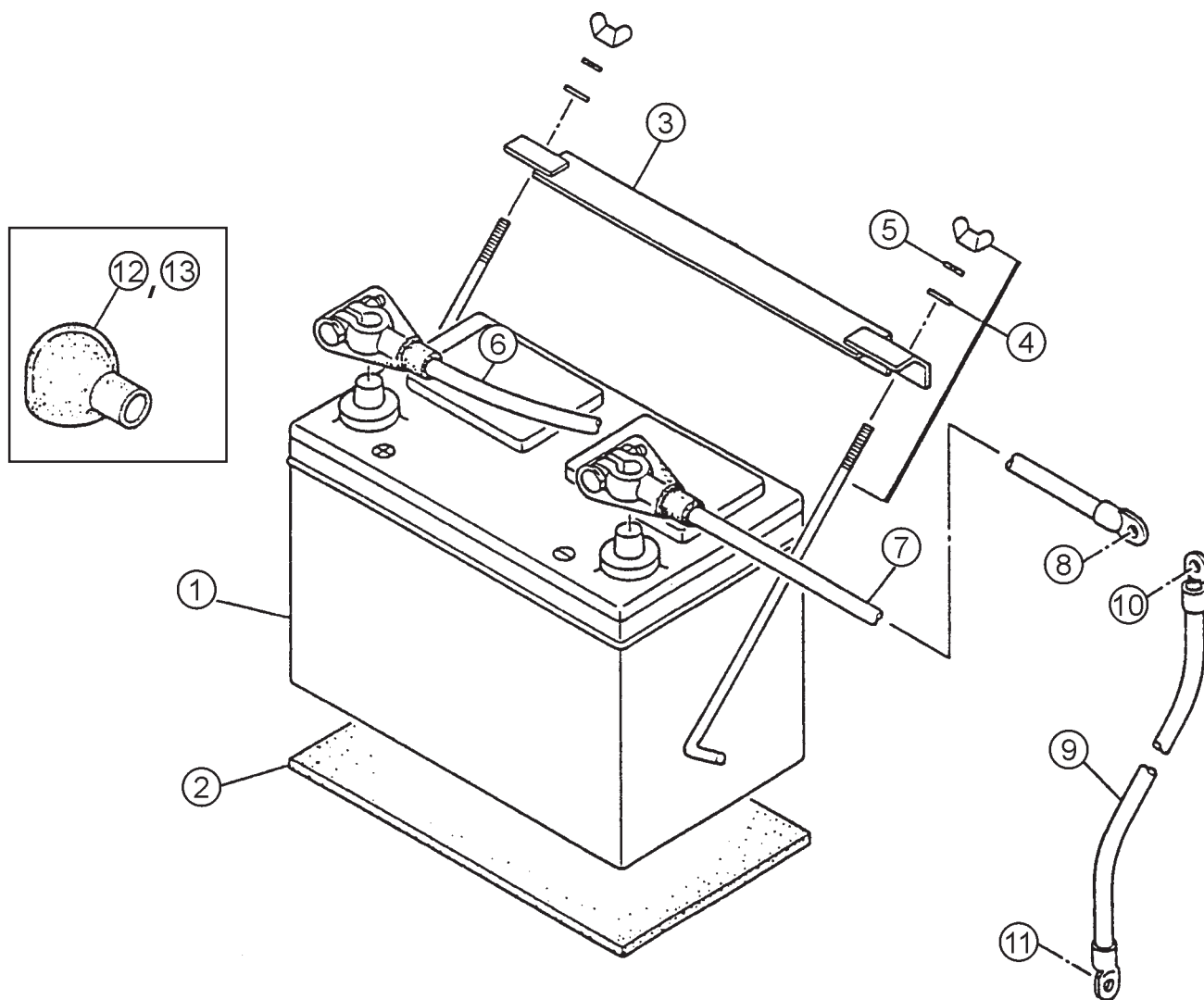

# DCA-70SSJU SERIES — BATTERY ASSY.

## BATTERY ASSY.

<u>NO.</u>	<u>PART NO.</u>	<u>PART NAME</u>	<u>QTY.</u>	<u>REMARKS</u>
1	551010280	BATTERY .....	1 .....	627MFD REPLACES 0602220187
2	M9310500014	BATTERY SHEET	1	
3	M9103000304	BATTERY BAND	1	
4	0602220920	BATTERY BOLT SET	2	
5	0040006000	LOCK WASHER	2	
6	M1346400004	BATTERY CABLE .....	1 .....	S/N7300001 TO S/N7302045
6	M1346400204	BATTERY CABLE .....	1 .....	S/N7302046~
7	M2346400104	BATTERY CABLE	1	
8	011008020	HEX HEAD BOLT .....	1 .....	REPLACES 0016908020
	0040508000	TOOTHED WASHER	1	
9		CABLE, GROJND .....	1 .....	MAKE LOCALLY
10	0017112025	HEX HEAD BOLT	1	
10	0040512000	TOOTHED WASHER	1	
11	012210020	HEX HEAD BOLT .....	1 .....	REPLACES 0017110020
11	0040510000	TOOTHED WASHER	1	
12	M1346400004	TERMINAL COVER .....	1 .....	S/N7300001 TO S/N7300003 REPLACES M9310000304
13	M1346400104	TERMINAL COVER .....	1 .....	S/N7300001 TO S/N7300003 REPLACES M9310000204

# DCA-70SSJU SERIES — MUFFLER ASSY.

MUFFLER ASSY.

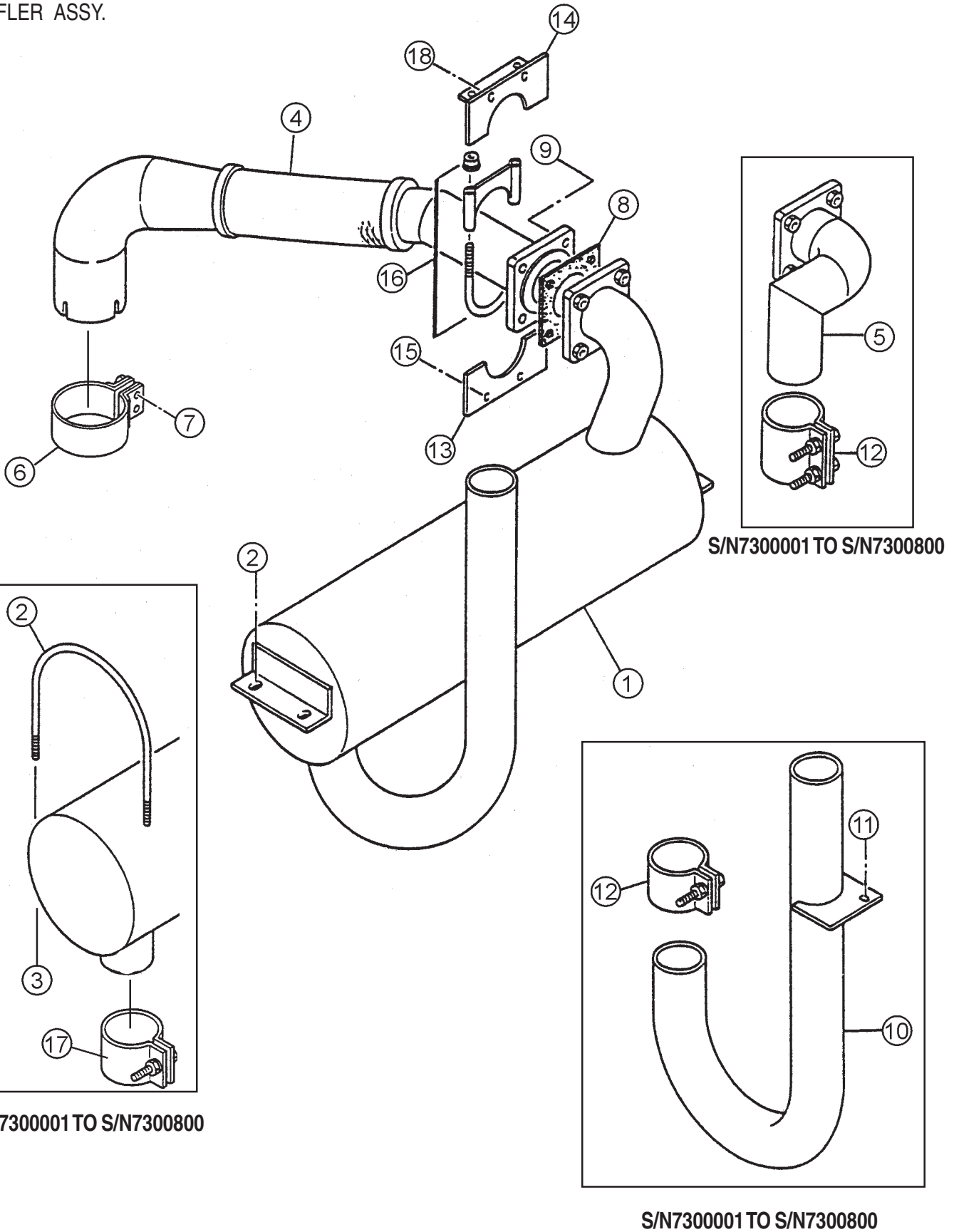



# DCA-70SSJU SERIES — MUFFLER ASSY.

## MUFFLER ASSY.

<u>NO.</u>	<u>PART NO.</u>	<u>PART NAME</u>	<u>QTY.</u>	<u>REMARKS</u>
1	0602300162	MUFFLER .....	1 .....	S/N7300001 TO S/N7300800
1	0602300166	MUFFLER .....	1 .....	S/N7300801~
2	M2330400204	U BOLT .....	2 .....	S/N7300001 TO S/N7300800
2	012210025	HEX HEAD BOLT .....	4 .....	S/N7300801~
		.....		REPLACES 0016910025
3	020108060	HEX NUT .....	4 .....	S/N7300001 TO S/N7300800
		.....		REPLACES 0037908000
3	031108160	PLAIN WASHER .....	4 .....	S/N7300001 TO S/N7300800
		.....		REPLACES 0041208000
4	M2333000303	EXHAUST PIPE .....	1 .....	S/N7300001 TO S/N7300020
4	M2333000313	EXHAUST PIPE .....	1 .....	S/N7300021 TO S/N7300180
4	M2333000323	EXHAUST PIPE .....	1 .....	S/N7300181 TO S/N7300363
4	M2333000333	EXHAUST PIPE .....	1 .....	S/N7300364~
5	M2333000203	EXHAUST PIPE .....	1 .....	S/N7300001 TO S/N7300020
5	M2333000213	EXHAUST PIPE .....	1 .....	S/N7300021 TO S/N7300180
5	M2333000223	EXHAUST PIPE .....	1 .....	S/N7300181 TO S/N7300800
6	M2333300104	SEAL CLAMP .....	1 .....	S/N7300001 TO S/N7300003
6	0602325065	CLAMP .....	1 .....	S/N7300004 TO S/N7300400
6	0602325066	CLAMP .....	1 .....	S/N7300401~
7	011008040	HEX HEAD BOLT .....	2 .....	S/N7300001 TO S/N7300003
		.....		REPLACES 0010108040
8	M2333200004	GASKET .....	1 .....	REPLACES M2333200014
9	0012108035	HEX HEAD BOLT .....	4 .....	REPLACES 0016908035
10	M2333100204	TAIL PIPE .....	1 .....	S/N7300001 TO S/N7300800
11	011008020	HEX HEAD BOLT .....	1 .....	S/N7300001 TO S/N7300800
		.....		REPLACES 0016908020
12	0602325022	CLAMP .....	1 .....	REPLACES 0602325089
13	M2330400304	COVER .....	1 .....	S/N7300001 TO S/N7300180
13	M2330400314	COVER .....	1 .....	S/N7300181~
14	M2333300003	BRACKET .....	1 .....	S/N7300001 TO S/N7300180
14	M2333300013	BRACKET .....	1 .....	S/N7300181~
15	011106015	HEX HEAD BOLT .....	4 .....	S/N7300001 TO S/N7300140
		.....		REPLACES 0016906015
15	011106015	HEX HEAD BOLT .....	2 .....	S/N7300141~
		.....		REPLACES 0016906015
16	0602326060	U BOLT SET	1	
17	0602325022	CLAMP .....	1 .....	S/N7300001 TO S/N7300800
18	011106015	HEX. HEAD BOLT .....	2 .....	S/N7302141~
		.....		REPLACES 0016906015
18	0207000600	HEX. NUT .....	2 .....	S/N7302141~

# DCA-70SSJU SERIES — FUEL TANK ASSY.

FUEL TANK ASSY.

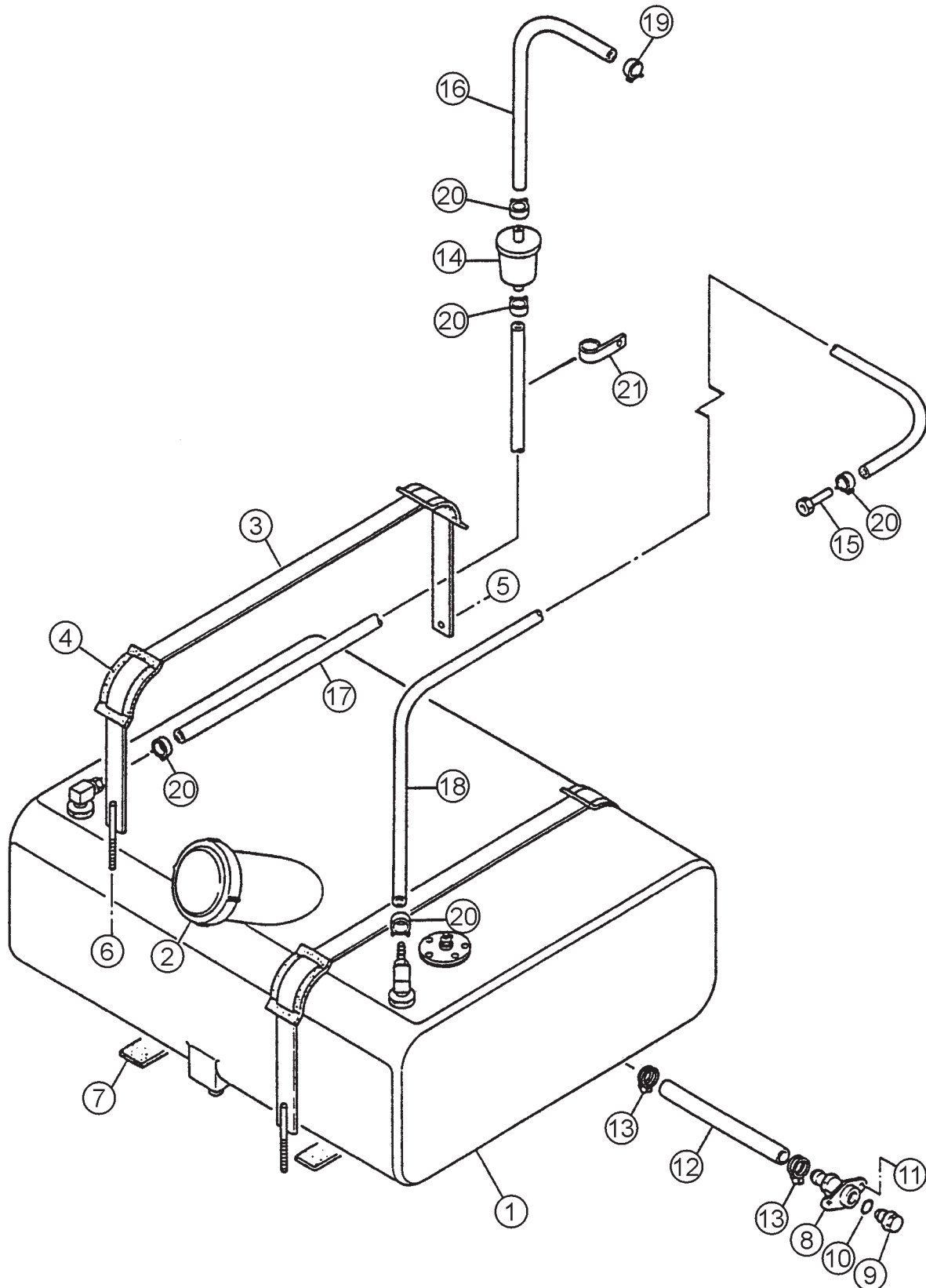

# DCA-70SSJU SERIES — FUEL TANK ASSY.

## FUEL TANK ASSY.

<u>NO.</u>	<u>PART NO.</u>	<u>PART NAME</u>	<u>QTY.</u>	<u>REMARKS</u>
1	M2363000102	FUEL TANK	1	
2	0605505070	CAP, FUEL TANK	1	
3	M2363200104	TANK BAND	2	
4	M9310500104	SUPPORTER SHEET	4	
5	011008020	HEX HEAD BOLT .....	2	REPLACES 0016908020
6	020108060	HEX NUT .....	2	S/N7300001 TO S/N7300610
		.....		REPLACES 0037908000
6	0207308000	HEX NUT .....	2	S/N7300611~
6	031108160	PLAIN WASHER .....	2	S/N7300001 TO S/N7300610
		.....		REPLACES 0041208000
7	0222100178	RUBBER SHEET	4	
8	M9200000003	DRAIN JOINT	1	
9	M9200200004	DRAIN BOLT	1	
10	0150000018	O RING	1	
11	011206020	HEX HEAD BOLT .....	2	REPLACES 0016906020
12	M1363400104	DRAIN HOSE	1	
13	0605515198	HOSE BAND .....	2	REPLACES 0605515198
14	0602042420	FUEL FILTER .....	1	PTG15P
15	0602042601	LEAK-OFF LINE .....	1	RE67050
16	0191300450	SUCTION HOSE	1	
17	0191301600	SUCTION HOSE	1	
18	0191302000	RETURN HOSE	1	
19	0605515189	HOSE BAND	1	
20	0605515109	HOSE BAND	5	
21	0602220911	CLAMP	1	

# DCA-70SSJU SERIES — ENCLOSURE ASSY.

ENCLOSURE ASSY.

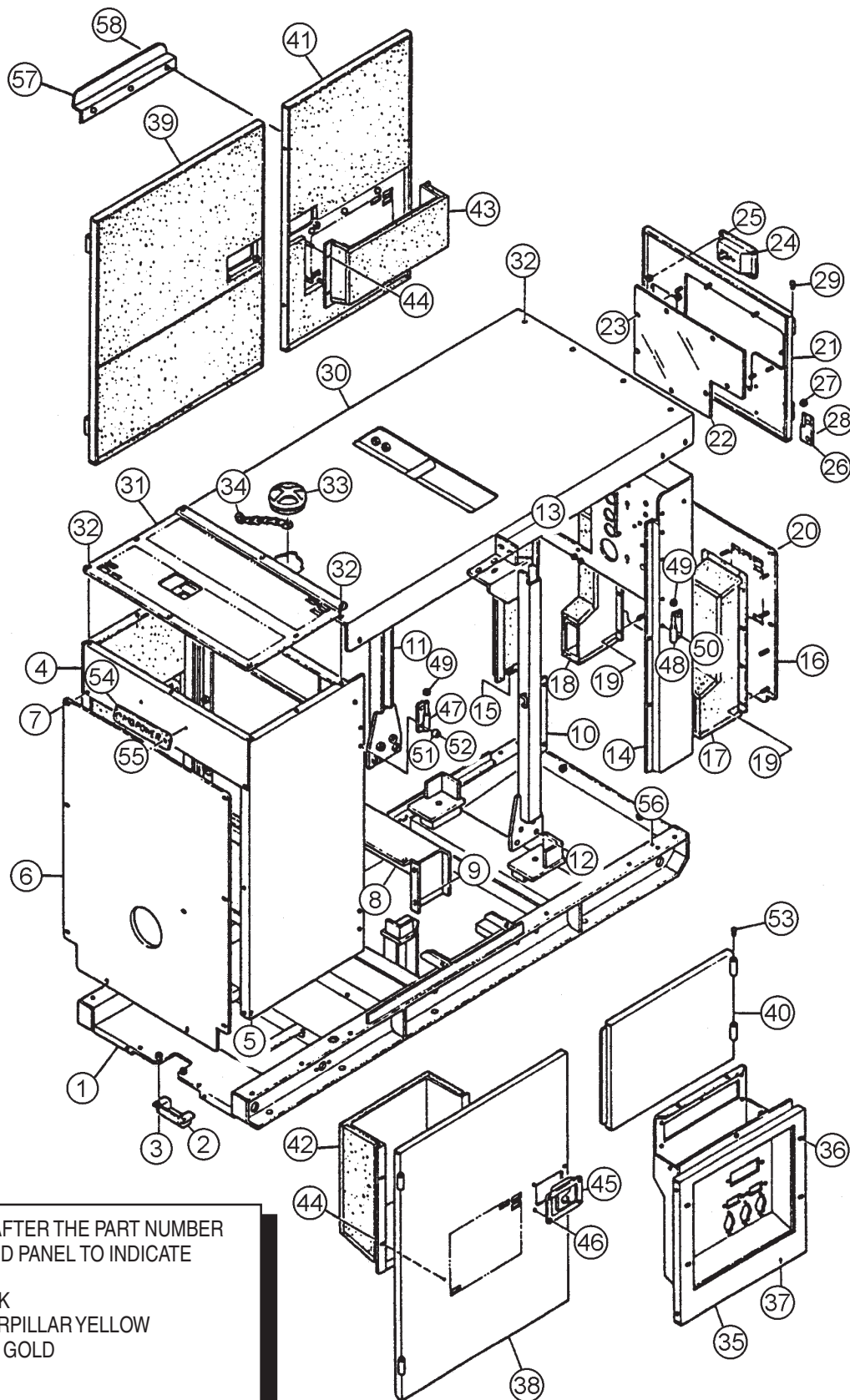

ADD THE FOLLOWING DIGITS AFTER THE PART NUMBER  
WHEN ORDERING ANY PAINTED PANEL TO INDICATE  
COLOR OF UNIT:

- |                 |                      |
|-----------------|----------------------|
| 1-ORANGE        | 5-BLACK              |
| 2-WHITE         | 6-CATERPILLAR YELLOW |
| 3-SPECTRUM GRAY | 7-CATO GOLD          |
| 4-SUNBELT GREEN |                      |

THE SERIAL NUMBER MAY BE REQUIRED.

# DCA-70SSJU SERIES — ENCLOSURE ASSY.

## ENCLOSURE ASSY.

<u>NO.</u>	<u>PART NO.</u>	<u>PART NAME</u>	<u>QTY.</u>	<u>REMARKS</u>
1	M2413000102	BASE .....	1	S/N7300001 TO S/N7300003
1	M2413000112	BASE .....	1	S/N7300004 TO S/N7301200
1	M2413000212	BASE .....	1	S/N7301201 TO S/N7302140
1	M2415000203	BASE .....	1	S/N7302141~
2	M1413400004	UNDER COVER	1	
3	011008020	HEX HEAD BOLT .....	2	REPLACES 0016908020
4	M2423000102	FRONT FRAME .....	1	S/N7300001 TO S/N7300003
4	M2423000112	FRONT FRAME .....	1	S/N7300004 TO S/N7300180
4	M2423000212	FRONT FRAME .....	1	S/N7300181 TO 7302140
		.....		REPLACES M2423000202
		.....		AND M242300122
4	M2425000003	FRONT FRAME .....	1	S/N7302141~
4	M2493101203	ACOUSTIC SHEET .....	1	REPLACES M2493101213
5	0016908020	HEX HEAD BOLT	6	
6	M2423200214	COVER, FRONT FRAME	1	
6	M2493101104	ACOUSTIC SHEET	1	
7	011008020	HEX HEAD BOLT .....	11	REPLACES 0016908020
8	M2423200303	INNER COVER, FRONT FRAME .....	1	S/N7300001 TO S/N7300003
8	M2423200313	INNER COVER, FRONT FRAME .....	1	S/N7300004~
9	011008020	HEX HEAD BOLT .....	6	S/N7300001 TO S/N7300003
		.....		REPLACES 0016908020
9	011008020	HEX HEAD BOLT .....	7	S/N7300004~
		.....		REPLACES 0016908020
10	M2433000203	CENTER FRAME .....	1	S/N7300001 TO S/N7302175
10	M2435000203	CENTER FRAME .....	1	S/N7302176
11	M2433000303	CENTER FRAME	1	
12	0010114030	HEX HEAD BOLT	8	
12	030214350	LOCK WASHER .....	8	REPLACES 0040014000
12	031114260	PLAIN WASHER .....	8	REPLACES 0041214000
13	012212030	HEX HEAD BOLT .....	10	REPLACES 0017112030
14	M2443000102	REAR FRAME .....	1	S/N7300001 TO S/N7300003
14	M2443000112	REAR FRAME .....	1	S/N7300004 TO S/N7302175
14	M2445000103	REAR FRAME .....	1	S/N7302176~
14	M2493300904	ACOUSTIC SHEET	1	
15	011008020	HEX HEAD BOLT .....	4	REPLACES 0016908020
16	M2443300703	REAR COVER .....	1	S/N7300001 TO 7300003
16	M2443300713	REAR COVER .....	1	S/N7300004~
17	M2443300613	DUCT, REAR COVER	1	
17	M2493300704	ACOUSTIC SHEET	1	
18	M2443300513	DUCT, REAR COVER	1	
18	M2493300604	ACOUSTIC SHEET	1	
19	0207006000	HEX NUT	16	
20	01100802	HEX HEAD BOLT .....	8	S/N7300001 TO S/N7300003
		.....		REPLACES 0016908020
20	01100802	HEX HEAD BOLT .....	9	S/N7300004~
		.....		REPLACES 001690802

# DCA-70SSJU SERIES — ENCLOSURE ASSY. (CONT.)

ENCLOSURE ASSY. (CONT.)

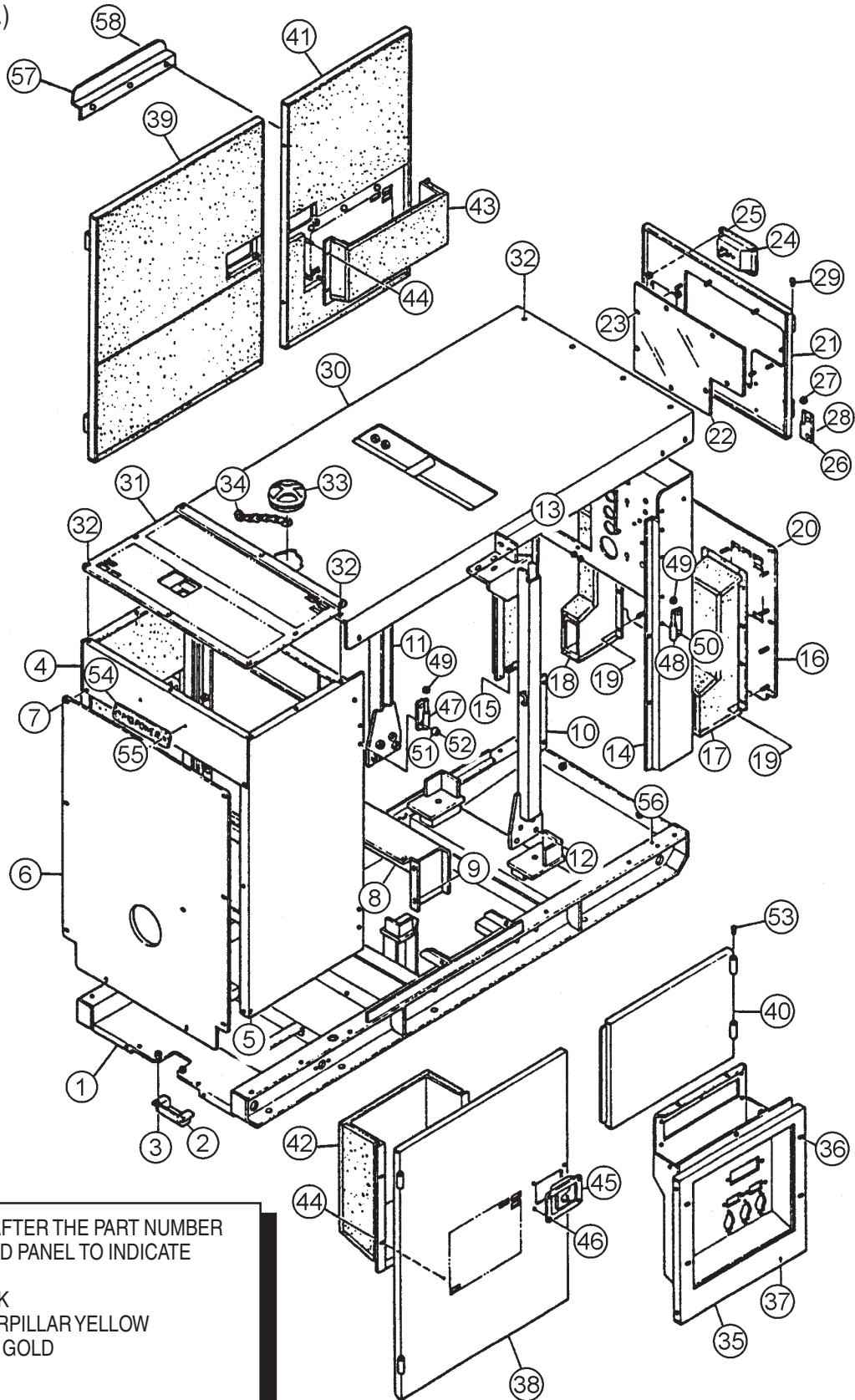

ADD THE FOLLOWING DIGITS AFTER THE PART NUMBER WHEN ORDERING ANY PAINTED PANEL TO INDICATE COLOR OF UNIT:

- |                 |                      |
|-----------------|----------------------|
| 1-ORANGE        | 5-BLACK              |
| 2-WHITE         | 6-CATERPILLAR YELLOW |
| 3-SPECTRUM GRAY | 7-CATO GOLD          |
| 4-SUNBELT GREEN |                      |

THE SERIAL NUMBER MAY BE REQUIRED.

# DCA-70SSJU SERIES — ENCLOSURE ASSY. (CONT.)

## ENCLOSURE ASSY. (CONT.)

<b>NO.</b>	<b>PART NO.</b>	<b>PART NAME</b>	<b>QTY.</b>	<b>REMARKS</b>
21	M2443200103	REAR DOOR .....	1	S/N7300001 TO S/N7300003
21	M2443200123K	REAR DOOR .....	1	S/N7300004 TO S/N7300680
		.....		REPLACES M2443200113
21	M2443200123	REAR DOOR .....	1	S/N7300681~
22	M1443600004	WINDOW PLATE .....	1	S/N7300001 TO S/N7300260
22	M1443600104	WINDOW PLATE .....	1	S/N7300261 TO 7300680
22	M1443600204	WINDOW PLATE .....	1	S/N7300681~
23	020106050	HEX NUT .....	6	UP TO 7300680
		.....		REPLACES 0207306000
23	020106050	HEX NUT .....	8	S/N7300681~
		.....		REPLACES 0207306000
23	952404470	PLAIN WASHER .....	12	S/N7300001 TO S/N7300610
		.....		REPLACES 0041206000
23	952404470	PLAIN WASHER .....	6	S/N7300611 TO 7300680
		.....		REPLACES 0041206000
23	952404470	PLAIN WASHER .....	8	S/N7300681~
		.....		REPLACES 0041206000
24	B9114000002	DOOR HANDLE ASSY .....	1	REPLACES M9113000002
25	0027106016	MACHINE SCREW .....	4	REPLACES 0021806015
25	020106050	HEX NUT .....	4	REPLACES 0030006000
26	M9110100204	HINGE	2	
27	M9116100004	WASHER	2	
28	011008020	HEX HEAD BOLT .....	3	REPLACES 0016908020
29	0845031504	BLIND PLUG .....	2	REPLACES M9310000004
30	M2463000102	ROOF PANEL .....	1	S/N7300001 TO S/N7300267
30	M2463000202	ROOF PANEL .....	1	S/N7300268~
30	M2493500123	ACOUSTIC SHEET .....	1	REPLACES M2493500103
		.....		AND M2493500113
31	M2463500104	OVER COVER, FRONT FRAME .....	1	S/N7300001 TO S/N7300800;
		.....		REPLACES M2463500104
31	M2463500114	OVER COVER, FRONT FRAME .....	1	S/N7300801~
32	011008020	HEX HEAD BOLT .....	18	REPLACES 0016908020
33	1625165103	BONNET CAP .....	1	REPLACES M9310000103
34	1625165204	CHAIN ASSY .....	1	REPLACES M1483600204
35	M2453200102	SPLASHER PANEL .....	1	S/N7300001 TO S/N7300140
35	M2236100504	ACOUSTIC SHEET .....	1	S/N7300001 TO S/N7300140
35	M2453200112	SPLASHER PANEL .....	1	S/N7300141 TO S/N7301140
35	M2236100504	ACOUSTIC SHEET .....	1	S/N7300141 TO S/N7301140
35	M2453200122	SPLASHER PANEL .....	1	S/N7301141 TO S/N7301260
35	M2236100504	ACOUSTIC SHEET .....	1	S/N7301141 TO S/N7301260
35	M2453200132	SPLASHER PANEL .....	1	S/N7301261 TO S/N7302175
35	M2236100504	ACOUSTIC SHEET .....	1	S/N7301261 TO S/N7302175
35	M2455200203	SPLASHER PANEL .....	1	S/N7302176~
35	M3236100104	ACOUSTIC SHEET .....	1	S/N7302176~
36	011208060	HEX HEAD BOLT .....	4	REPLACES 0016908055
37	011008020	HEX HEAD BOLT .....	2	REPLACES 0016908020

# DCA-70SSJU SERIES — ENCLOSURE ASSY. (CONT.)

ENCLOSURE ASSY. (CONT.)

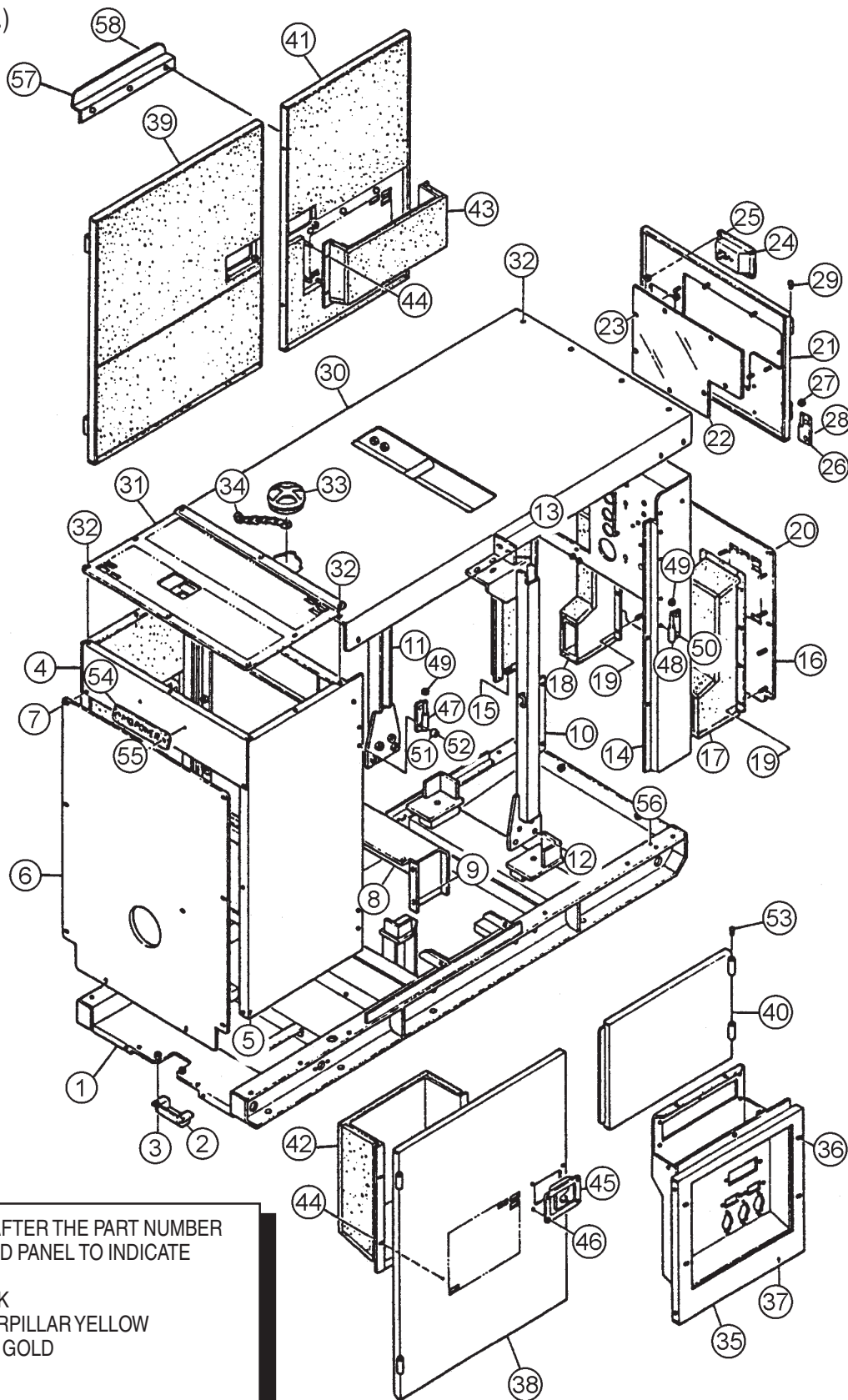

ADD THE FOLLOWING DIGITS AFTER THE PART NUMBER  
WHEN ORDERING ANY PAINTED PANEL TO INDICATE  
COLOR OF UNIT:

- |                 |                      |
|-----------------|----------------------|
| 1-ORANGE        | 5-BLACK              |
| 2-WHITE         | 6-CATERPILLAR YELLOW |
| 3-SPECTRUM GRAY | 7-CATO GOLD          |
| 4-SUNBELT GREEN |                      |

THE SERIAL NUMBER MAY BE REQUIRED.



## DCA-70SSJU SERIES — ENCLOSURE ASSY. (CONT.)

### ENCLOSURE ASSY. (CONT.)

<u>NO.</u>	<u>PART NO.</u>	<u>PART NAME</u>	<u>QTY.</u>	<u>REMARKS</u>
38	M2453000503	SIDE DOOR	1	
38	M2493400904	ACOUSTIC SHEET	1	
39	M2453000603	SIDE DOOR	1	
39	M2493401104	ACOUSTIC SHEET	1	
40	M2453000703	SIDE DOOR .....	1 .....	S/N7300001 TO S/N7302175
40	M2455000103	SIDE DOOR .....	1 .....	S/N7302176~
40	M2493401904	ACOUSTIC SHEET .....	1 .....	S/N7300001 TO S/N7302175
40	M2495400304	ACOUSTIC SHEET .....	1 .....	S/N7302176~
41	M2453000803	SIDE DOOR .....	1 .....	S/N7300001 TO S/N7302175
41	M2453000813	SIDE DOOR .....	1 .....	S/N7302176~
41	M2493401204	ACOUSTIC SHEET	1	
42	M2453300503	DUCT	1	
42	M2493401004	ACOUSTIC SHEET	1	
43	M2453300603	DUCT	1	
43	M2493401304	ACOUSTIC SHEET	1	
44	0207006000	HEX NUT	13	
45	B9114000002	DOOR HANDLE ASSY .....	3 .....	REPLACES M9113000002
46	0027106016	MACHINE SCREW .....	12 .....	REPLACES 0021806015
46	020106050	HEX NUT .....	12 .....	REPLACES 0030006000
47	M9110100204	HINGE	4	
48	M9110100304	HINGE	4	
49	M9116100004	WASHER	8	
50	011008020	HEX HEAD BOLT .....	9 .....	REPLACES 0016908020
51	0601850097	DOOR STOPPER	8	
52	0027208025	MACHINE SCREW	8	
53	0845031504	BLIND PLUG .....	8 .....	REPLACES M9310000004
54	0600500090	EMBLEM	1	
55	0021106015	MACHINE SCREW	2	
56	011008020	HEX HEAD BOLT .....	1 .....	REPLACES 0016908020
56	0040508000	TOOTHED WASHER	1	
57	M2455600004	DOOR BRACKET	1	
58	0111006015	HEX HEAD BOLT .....	3 .....	REPLACES 0016906015

# DCA-70SSJU SERIES — RUBBER SEAL ASSY.

RUBBER SEAL ASSY.

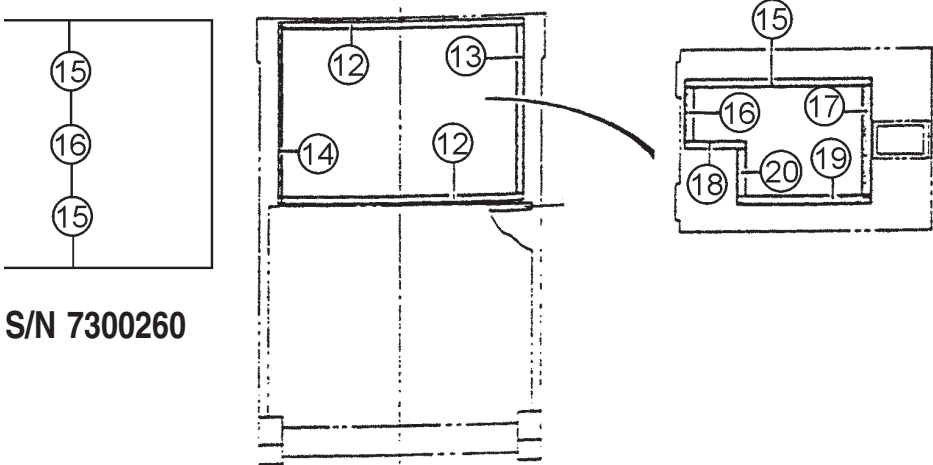
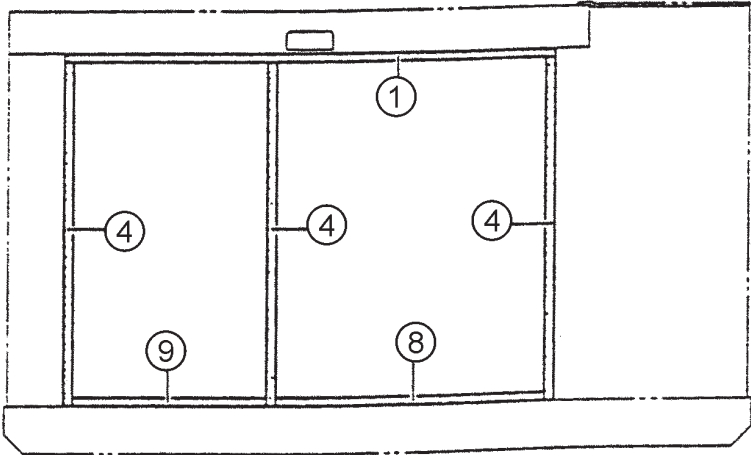
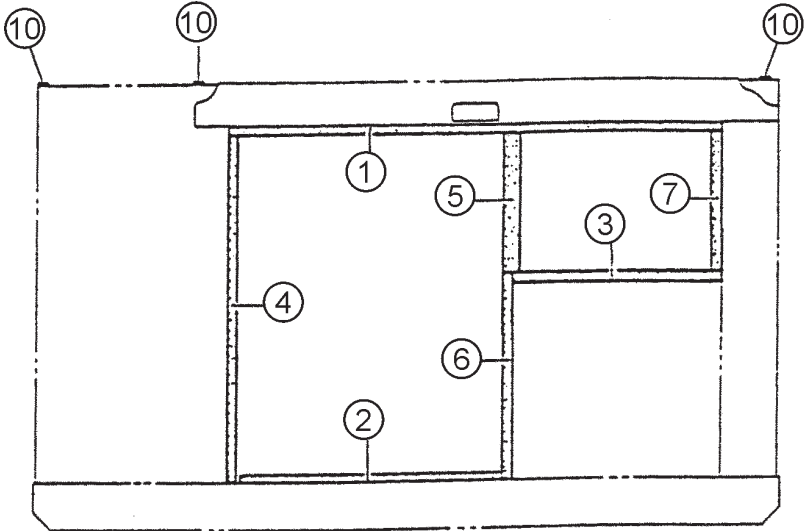

S/N 7300001 TO S/N 7300260

# DCA-70SSJU SERIES — RUBBER SEAL ASSY.

RUBBER SEALS ASSY.

<u>NO.</u>	<u>PART NO.</u>	<u>PART NAME</u>	<u>QTY.</u>	<u>REMARKS</u>
1	0228901580	RUBBER SEAL	2	
2	0229200825	RUBBER SEAL	1	
3	0228900670	RUBBER SEAL	1	
4	0228901090	RUBBER SEAL	4	
5	M2490300004	RUBBER SEAL .....	1 .....	S/N7300001 TO S/N7302175
5	M2492300004	RUBBER SEAL .....	1 .....	S/N7302176~
6	0228800590	RUBBER SEAL .....	1 .....	S/N7300001 TO 7302175
6	0228800665	RUBBER SEAL .....	1 .....	S/N7302176~
7	0228900500	RUBBER SEAL .....	1 .....	S/N7300001 TO S/N7302175
7	0228900425	RUBBER SEAL .....	1 .....	S/N7302176~
8	0228900860	RUBBER SEAL	1	
9	0228900630	RUBBER SEAL	1	
10	0229200900	RUBBER SEAL	2	
11	0229200840	RUBBER SEAL	1	
12	0228800770	RUBBER SEAL	2	
13	0228800540	RUBBER SEAL	1	
14	0228800580	RUBBER SEAL	1	
15	0228100565	RUBBER SEAL .....	2 .....	S/N7300001 TO S/N7300680
15	0228100550	RUBBER SEAL .....	1 .....	S/N7300681~
16	0228100170	RUBBER SEAL .....	2 .....	S/N7300001 TO S/N7300680
16	0228100170	RUBBER SEAL .....	1 .....	S/N7300681~
17	NS2016	RUBBER SEAL .....	1 .....	S/N7300681~
		.....		REPLACES 0228100350
18	0228100170	RUBBER SEAL .....	1 .....	S/N7300681~
19	0228100360	RUBBER SEAL .....	1 .....	S/N7300681~
20	0228100180	RUBBER SEAL .....	1 .....	S/N7300681~

**PAYMENT TERMS**

Terms of payment for parts are net 10 days.

**FREIGHT POLICY**

All parts orders will be shipped collect or prepaid with the charges added to the invoice. All shipments are F.O.B. point of origin. Multiquip's responsibility ceases when a signed manifest has been obtained from the carrier, and any claim for shortage or damage must be settled between the consignee and the carrier.

**MINIMUM ORDER**

The minimum charge for orders from Multiquip is \$15.00 net. Customers will be asked for instructions regarding handling of orders not meeting this requirement.

**RETURNED GOODS POLICY**

Return shipments will be accepted and credit will be allowed, subject to the following provisions:

1. A Returned Material Authorization must be approved by Multiquip prior to shipment.
2. To obtain a Return Material Authorization, a list must be provided to Multiquip Parts Sales that defines item numbers, quantities, and descriptions of the items to be returned.
  - a. The parts numbers and descriptions must match the current parts price list.
  - b. The list must be typed or computer generated.
  - c. The list must state the reason(s) for the return.
  - d. The list must reference the sales order(s) or invoice(s) under which the items were originally purchased.
  - e. The list must include the name and phone number of the person requesting the RMA.
3. A copy of the Return Material Authorization must accompany the return shipment.
4. Freight is at the sender's expense. All parts must be returned freight prepaid to Multiquip's designated receiving point.

5. Parts must be in new and resalable condition, in the original Multiquip package (if any), and with Multiquip part numbers clearly marked.
6. The following items are not returnable:
  - a. Obsolete parts. (If an item is in the price book and shows as being replaced by another item, it is obsolete.)
  - b. Any parts with a limited shelf life (such as gaskets, seals, "O" rings, and other rubber parts) that were purchased more than six months prior to the return date.
  - c. Any line item with an extended dealer net price of less than \$5.00.
  - d. Special order items.
  - e. Electrical components.
  - f. Paint, chemicals, and lubricants.
  - g. Decals and paper products.
  - h. Items purchased in kits.
7. The sender will be notified of any material received that is not acceptable.
8. Such material will be held for five working days from notification, pending instructions. If a reply is not received within five days, the material will be returned to the sender at his expense.
9. Credit on returned parts will be issued at dealer net price at time of the original purchase, less a 15% restocking charge.
10. In cases where an item is accepted, for which the original purchase document can not be determined, the price will be based on the list price that was effective twelve months prior to the RMA date.
11. Credit issued will be applied to future purchases only.

**PRICING AND REBATES**

Prices are subject to change without prior notice. Price changes are effective on a specific date and all orders received on or after that date will be billed at the revised price.

Rebates for price declines and added charges for price increases will not be made for stock on hand at the time of any price change.

Multiquip reserves the right to quote and sell direct to Government agencies, and to Original Equipment Manufacturer accounts who use our products as integral parts of their own products.

**SPECIAL EXPEDITING SERVICE**

A \$35.00 surcharge will be added to the invoice for special handling including bus shipments, insured parcel post or in cases where Multiquip must personally deliver the parts to the carrier.

**LIMITATIONS OF SELLER'S LIABILITY**

Multiquip shall not be liable here under for damages in excess of the purchase price of the item with respect to which damages are claimed, and in no event shall Multiquip be liable for loss of profit or good will or for any other special, consequential or incidental damages.

**LIMITATION OF WARRANTIES**

No warranties, express or implied, are made in connection with the sale of parts or trade accessories nor as to any engine not manufactured by Multiquip. Such warranties made in connection with the sale of new, complete units are made exclusively by a statement of warranty packaged with such units, and Multiquip neither assumes nor authorizes any person to assume for it any other obligation or liability whatever in connection with the sale of its products. Apart from such written statement of warranty, there are no warranties, express, implied or statutory, which extend beyond the description of the products on the face hereof.



# OPERATION AND PARTS MANUAL

## **HERE'S HOW TO GET HELP**

*PLEASE HAVE THE MODEL AND SERIAL  
NUMBER ON-HAND WHEN CALLING*

### **PARTS DEPARTMENT**

*800-427-1244 or 310-537-3700*

*FAX: 800-672-7877 or 310-637-3284*

### **SERVICE DEPARTMENT**

*800-421-1244*

*FAX: 310- 537-4259*

### **TECHNICAL ASSISTANCE**

*800-478-1244*

*FAX: 310- 631-5032*

### **WARRANTY DEPARTMENT**

*888-661-4279, or 310-661-4279*

*FAX: 310- 537-1173*



#### **MULTIQUIP INC.**

18910 WILMINGTON AVE.  
CARSON, CALIFORNIA 90746  
310-537-3700  
800-421-1244  
FAX:310-537-3927

E-mail:mq@multiquip.com • www:multiquip.com

#### **PARTS DEPARTMENT:**

800-427-1244  
FAX: 800-672-7877

#### **SERVICE DEPARTMENT:**

800-835-2551  
FAX:310-638-8046